



ORIGINAL COULD

2 0 1 1

MERCEDES-BENZ





- Autostrada Motorway
- Tangenziale Circular Road
- Provinciale Country Road
- Comunale Municipal Road



COVIND S.p.A.
Strada della Cebrosa, 68/70/72 Settimo T.se (TO)



STAMPAUTO S.r.l.
Via Alessandria, 59/61 Cascine Vica, Rivoli (TO)



*Societa'®
Karman
Stampotech*



KARMAN STAMPOTECH S.r.l.
Via Torino, 10/12 Airasca (TO)



MERCEDES-BENZ

ottobre 2011 - october 2011 - Oktober 2011



**BUREAU
VERITAS**

SGS



ecology: we can!

www.covind.it





Tutti i particolari qui elencati, pur essendo perfettamente intercambiabili con gli originali, **non sono originali**. Gli stessi vengono impiegati ed utilizzati solo per i veicoli in circolazione e solo dopo autorizzazione da parte del proprietario del veicolo in riparazione. I numeri di riferimento originali sono riportati a puro titolo informativo. Nelle trattative e nelle ordinazioni si prega di voler sempre citare i nostri numeri di riferimento. Il presente catalogo annulla e sostituisce tutti i precedenti.



Todos los elementos detallados a continuación, aunque totalmente intercambiables con los originales, **no son originales**. Estos mismos se emplean y utilizan unicamente para vehículos en circulación y previa autorización del propietario del vehículo en reparación. Los numeros de referencia originales se citan a título informativo. En las negociaciones y en los pedidos se ruega citar siempre nuestros numeros de referencia. El presente catálogo anula y substituye todos los anteriores.



Κάθε ανταλλακτικό που απαριθμείται εδώ, ακόμα κι αν όντας τέλεια ανταλλάξιμο με το γνήσιο, **δεν είναι γνήσιο**. Αυτά τα μέρη χρησιμοποιούνται μόνο στα οχήματα που είναι σε κυκλοφορία και αποκλειστικά μετά από την έγκριση του ιδιοκτήτη του οχήματος για επισκευή. Οι γνήσιοι κωδικοί που αναφέρονται υπάρχουν για πληροφοριακούς λόγους μόνο. Παρακαλούμε όπως χρησιμοποιείτε για οποιαδήποτε συναλλαγή/ παραγγελία σας τους δικούς μας αναφερόμενους κωδικούς. Ο παρών κατάλογος ακυρώνει και αντικαθιστά προηγούμενους.



Spare parts listed here, even though perfectly interchangeable with the original ones, **are not original**. These parts are used only on vehicles in circulation and exclusively under authorization of the owner of the vehicle in repair. The original reference codes are indicated for information only. You are kindly requested to indicate our reference codes in negotiations and order sheets. The present catalogue list cancels and replaces previous ones.



Veškeré zde uvedené součástky **nejsou originální díly**, i když jsou za ně stoprocentně zaměnitelné. Tyto součástky je možné použít pouze pro vozidla v provozu a pouze se souhlasem majitele vozidla, které má být opraveno. Referenční čísla originálních dílů jsou uvedena pouze informativně. Při jednáních a na objednávkách je nutné vždy uvést naše referenční čísla. Tento katalog anuluje a nahrazuje veškeré předchozí katalogy.



Hoewel elk reserveonderdeel dat hier vermeld wordt perfect kan worden gebruikt in de plaats van de originele stukken, **gaat het hier dus niet om originele onderdelen**. Deze onderdelen worden enkel gebruikt voor voertuigen in circulatie en enkel met de toestemming van de eigenaar van het voertuig dat in reparatie is. De originele referentiecodes worden enkel ter informatie weergegeven. U wordt vriendelijk verzocht om onze referentiecodes te gebruiken in gesprekken en op de bestelformulieren. De huidige catalogoog annuleert en vervangt de vorige versies.



Reservedelene som er oppført her, er ikke **originale reservedeler**, selv om de fullt ut kan benyttes ved utskiftning av de opprinnelige delene. De skal kun benyttes på kjøretøy som er i bruk og med eierens samtykke. De opprinnelige referansekodene angis kun til etterretning. Vennligst angi våre referansekoder under forhandling og ved bestilling. Denne katalogen annullerer og erstatter alle tidligere kataloger.



Toate produsele enumerate in continuare, chiar daca sunt perfect interschimbabile cu cele originale, **nu sunt originale**. Ele sunt utilizate, numai pentru autovehiculele in circulatie si exclusiv cu acordul proprietarului autovehiculului de reparat. Codurile originale sunt indicate numai in scop informativ. Cu ocazia tratativelor verbale, cat si a emiterii ordinelor scrise, clientii sunt rugati sa utilizeze codurile noastre(COVIND) ca referinta. Prezentul catalog anuleaza si le inlocuieste pe cele precedente.



Wszystkie detale tu podane ,choć będąc doskonałe wymienne z oryginałami, **nie są oryginalne**. Te same zostają zastosowane i użyte tylko dla pojazdów w obiegu i tylko po autoryzacji ze strony właściciela pojazdu będącego w naprawie. Oryginalne numery referencyjne są umieszczone w celu czysto informacyjnym. W czasie rozmów handlowych i zamówień, prosi się zechcieć zawsze cytować nasze numery referencyjne. Niniejszy katalog anuluje i zastępuje wszystkie poprzednie.



Todas as peças aqui listadas, ainda que sejam perfeitamente intercambiáveis com as originais, **não são originais**. Estas peças só são empregues e utilizadas nos veículos em circulação e só após autorização prévia por parte do proprietário do veículo a reparar. Os números de referência originais têm um carácter puramente informativo. Nos contactos e encomendas, indique sempre os números de referência, por favor.



Selv om de sagtens kan bruges i stedet for de originale er de reservedele der indgår i **denne liste ikke originale**. Disse reservedele bruges kun til aktive køretøjer og udelukkende med ejerens tilladelse, mens reparationen udføres. De originale referencekoder fremstår kun som en oplysning. De bedes angive vores referencekoder i.f.m. forhandlinger og bestillingssedler. Det nye katalog annullerer og erstatter alle tidligere udgaver.



Reservdelarna i denna lista är inte originaldelar trots att de **är fullkomligt utbytbara med de ursprungliga**. Dessa delar används endast på fordon i cirkulation och enbart efter godkännande av ägaren till det fordon som lämnats på reparation. De originala referenskoderna anges endast för information. Var god ange våra referens-koder i negocieringar och beställningssblanketter. Den nuvarande kataloglistan annullerar och ersätter de föregående.



Alle hier aufgeführten Bestandteile sind exakt austauschbar mit den Originalteilen, **aber es sind keine Originale**. Diese Teile werden nur angewendet und eingesetzt für die Fahrzeuge die im Umlauf sind und nur nach Einverständnis mit dem Eigentümer, dessen Fahrzeug in der Reparatur ist. Die Original-Referenznummern wurden rein informativ nochmals wiedergegeben. Bei Anfragen und bei Bestellungen bitten wir Sie immer die Referenznummern anzugeben. Der beigelegte Katalog ersetzt und annulliert die vorhergehenden Kataloge.



Всички особености изредени по-долу, независимо от това, че са взаимозаменяеми с оригиналите, **не са оригинали**. Те биват използвани само за превозните средства в движение и само след изпълномощаване от страна на собственика на превозното средство в ремонт.



Toutes les pièces détaillées ci-dessus, tout en étant parfaitement interchangeable avec les pièces d'origine, **ne sont pas originales**. Les mêmes pièces sont utilisées exclusivement sur les véhicules en circulation et seulement sous autorisation du propriétaire du véhicule en réparation. Les codes de référence originales sont indiqués à titre purement documentaire. Dans les négociations et les commandes veuillez bien citer nos codes de référence. Le présent catalogue annule et remplace tous les précédents.



Все перечисленные запчасти не являются оригинальными, **хотя могут отлично их заменить**. Эти запчасти используются при ремонте автомобилей только с согласия владельца.

Ссылки на порядковый номер оригинальных запчастей указаны исключительно в ориентировочных целях.

При покупках и заказах рекомендуем указывать НАШИ номера запчастей.

Настоящий каталог аннулирует и заменяет все предыдущие.

Оригинальные ориентировочные номера са изнесени само за ваша информация. При преговори и при поръчки молим винаги да цитирате нашите ориентировочни номера.

Настоящият каталог анулира и замества всички съществуващи до момента.



Tässä luetteloidut varaosat eivät ole alkuperäisosa, vaikka **ne ovatkin laadultaan alkuperäisosa vastaavia**. Osat on tarkoitettu käytettäväksi liikenteessä olevissa autoissa ja niitä käytetään vain korjattavan ajoneuvon omistajan luvalla. Alkuperäiset tuotekoodit mainitaan vain tiedon vuoksi. Pyydämme teitä käyttämään neuvotteluissa ja tilauslomakkeissa meidän tuotekoodejamme. Uusi tuoteluettelo peruuttaa ja korvaa aikaisemmat luettelot.



Selles nimekirjas olevad varuosad ei ole originaalid vaatamata sellele, **et on originaalidega võrdväärsest kasutatavad**. Neid osasid kasutada ainult töös olevatel sõidukitel ja üksnes remonditava sõiduki omaniku loal. Originaali viitenumbrid on ära toodud ainult infoks. Palume müügi- ja tellimislehtedel ära märkida meie viitenumbrid. Käesoleva kataloogi nimekiri tühistab ja asendab varasemad.



Devamında detaylandırılan tüm elementler, orijinaleri ile tamamen değiştirilebilir olmasına rağmen, **orijinal değildirler**. Bunlar, yalnızca dolaşımda bulunan araçlarda ve tamirde bulunan aracın sahibinden ön onay alınması kaydıyla uygulanabilir ve kullanılabilir.
Orijinalerin referans numaraları bilgi başlığında yer almaktadır.
Görüşmelerde ve siparişlerde referans numaralarımızın her zaman belirtilmesi rica olunur.
Bu katalog tüm önceki versiyonları geçersiz kılar ve bunların yerine geçer.



Kaut arī uzskaitītās rezerves daļas var pilnīgi aizstāt oriģinālās, **tās nav oriģinālas**. Šīs rezerves daļas tiek izmantotas vienīgi apgrozībā esošiem transporta līdzekļiem un tikai ar remontējamā transporta līdzekļa īpašnieka atļauju.
Oriģinālais atsauces numurs tiek uzrādīts vienīgi informācijai.
Lūdzam norādīt jūsu atsauces numurus sarunu laikā un uz pasūtījuma lapas. Šis kataloga saraksts anulē un aizstāj visus iepriekšējos.



Az itt felsorolt tartalék alkatrészek, még akkor is, ha megfelelően felcserélhetők az eredetiekkel, nem az eredetiek. Ezeket az alkatrészeket csak forgalomban lévő járművek javításánál használják és kizárólag a jármű tulajdonosának engedélyével.
Az eredeti referencia kódokat csak információs célból jelzik. Kérjük legyen szíves jelezze a referencia kódjainkat a tárgyalásokon és a megrendelési dokumentumban.
A jelenlegi katalógus lista vissza van vonva és újra az előző lista van érvényben.



Ovdje popisani prièuvni dijelovi, èak i kada savršeno zamjenjuju izvorne, **nisu izvorni**. Ti dijelovi mogu se uporabiti jedino na vozilima u cirkulaciji i na temelju izrièelitoga odobrenja vlasnika vozila na popravku.
Brojevi dijela izvornih dijelova navedeni su samo kao primjer. Najljepše vas molimo da u vašim zahtjevima i narudžbama navedete brojeve dijela.
Sadašnji katalog ukida valjanost svih prethodnih kataloga.



كافة التفاصيل المذكوره هنا وبالرغم من قابليتها للتبديل مع التفاصيل الاصلية بشكل متطابق تماما، إلا انها ليست الأصلية. نفس التفاصيل يتم الاستعانه بها واستخدامها فقط للعربات السائره فقط بعد الحصول على التصريح بالموافقه من مالك العربيه التي يتم إصلاحها.
الأرقام الارشاديه الأصلية يتم وضعها بغرض الاستعلام. نرجو أن يتم دائما ذكر أرقامنا الخاصة الارشاديه في التعاقدات وطلبات الشراء.
هذا الكاتالوج يلغي كافة الكاتالوجات السابقه ويحل محلها.



Перелічені тут запасні частини не є оригінальними, але цілком взаємозамінні з оригінальними. Ці запасні частини застосовуються тільки на транспортних засобах, що знаходяться в експлуатації і винятково з дозволу власника, що здав транспортний засіб у ремонт.

Коди оригінальних запасних частин наводяться тільки для довідки. Прохання вказувати довідкові коди запасних частин при веденні переговорів і на бланках замовлення.

Даний каталог скасовує дію раніше виданих каталогів і замінює ці каталоги.



Ěprav jih je možno perfektno izmenjati z originalnimi deli, tukaj navedeni nadomestni deli niso originalni. Te dele se uporabljajo samo v vozilih v prometu in izključno samo pod pogojem, da lastnika vozila v popravilu izda zato dovoljenje. Navedene originalne referenčne kode so le informativne. Prosimo vas, da navedite naše referenčne kode pri pogajanju in na naročilih. S sedanjim seznamom prenehajo veljati prejšnji sezname in jih nadomesti.



Čia išvardytos atsarginės dalys nėra originalios, tačiau jomis galima pakeisti originaliąsias. Šios dalys naudojamos tik apyvartoje esančiuose automobiliuose ir tik gavus remontuojamo automobilio savininko sutikimą.

Originalių dalių kodai nurodomi tik informacijos sumetimais. Maloniai prašome nusiskundimuose ir užsakymų lapuose nurodyti dalių kodus.

Šiame kataloge pateikiamas sąrašas anuliuoja ir pakeičia ankstesniusius.



قطعات قید شده در اینجا با اینکه آنها کاملاً قابل تعویض با قطعات اصلی می باشند. قطعات اصلی نیستند. این قطعات تنها برای خودروهایی که در جریان می باشند (خارج از محل تولید می باشند) مورد استفاده قرار می گیرند و منحصرأ تحت اختیار و نضر مالک خودروی در حال تعمیر می باشند.
با احترامات ما از شما شماره کد ارجاع اصلی تنها برای اطلاعات می باشند. تقاضا داریم که شماره کد ارجاع را در زمان مذاکره و در ورقه تقاضا مشخص کنید. لیست

1	Sprinter 2006 terza serie / third version / dritte Serie
11	Sprinter 2000-2005 seconda serie / second version / zweite Serie
23	Sprinter 1995-1999 prima serie / first version / erste Serie
33	MB 207
39	Vito
45	MB 100
49	Actros 3 terza serie / third series / dritte Serie
67	Actros 3 Mega Space
81	Actros 2 seconda serie / second version / zweite Serie
103	Actros 2 Mega Space
121	Actros 1 prima serie / first version / erste Serie
131	Actros 1 Mega Space
143	Axor seconda serie / second version / zweite Serie
151	Axor prima serie / first version / erste Serie
161	Atego seconda serie / second series / zweite Serie
167	Atego prima serie / first version / erste Serie
173	MB 670
177	MB 649
185	MB 641 powerline
193	MB 389
197	MB 381 guida sinistra / lh drive / linkslenker
209	MB 381 guida destra / rh drive / rechtslenker
215	MB 347
229	MB 322

Tabelle Comparative | Cross Reference | Korrespondenztabelle
MERCEDES-BENZ / COVIND

Tabelle Comparative | Cross Reference | Korrespondenztabelle
COVIND / MERCEDES-BENZ

Mercedes-Benz / Covind

Cod. Originale O.E.M. Ref. Oe Nummer	Cod. Covind Covind Ref. Covind teilnummer	Pagina Page Seite	Cod. Originale O.E.M. Ref. Oe Nummer	Cod. Covind Covind Ref. Covind teilnummer	Pagina Page Seite	Cod. Originale O.E.M. Ref. Oe Nummer	Cod. Covind Covind Ref. Covind teilnummer	Pagina Page Seite	Cod. Originale O.E.M. Ref. Oe Nummer	Cod. Covind Covind Ref. Covind teilnummer	Pagina Page Seite
-	347/372	226	3127200830	347/ 14	221	3226271901	322/162	235	3227271771	347/ 16	221
-	381/ 4	-	3127230035	347/181	220	3226271904	322/106	234	3227500902	322/145	231
-	381/ 10	201	3127230101	347/181	220	3226400950	347/315	226	3227600061	347/195	220
-	381/915	-	3127680002	347/196	221	3226403509	322/247	236	3227600161	347/194	220
-	381/965	-	3147600102	347/196	221	3226403609	322/246	236	3227660301	347/190	219
-	641/171	-	3148110114	347/ 25	219	3226460928	322/249	-	3227660701	347/198	219
-	649/162	179	3148110514	347/ 25	219	3226461028	322/248	-	3228100013	347/ 25	219
-	649/163	179	3196270035	347/100	222	3226470207	347/315	226	3228110214	347/ 25	219
-	930/022	63	3198100118	347/147	217	3226470307	347/315	226	3228111914	347/ 25	219
-	930/023	63	3226104510	322/185	238	3226570009	322/370	239	3228112004	347/ 25	219
-	930/032	63	3226104610	322/184	238	3226660028	347/213	224	3228300243	347/ 79	223
-	930/122	63	3226120134	347/217	224	3226660128	347/212	224	3228300343	347/ 78	223
-	930/123	63	3226123014	347/ 20	225	3226660432	347/215	224	3228300762	347/ 73	223
-	930/132	63	3226140025	347/231	224	3226660532	347/215	224	3228300862	347/ 72	223
-	940/941	122	3226140125	347/230	224	3226843960	347/411	225	3228301662	322/ 26	238
-	943/550	64	3226200110	347/ 77	223	3226844060	347/410	225	3228303562	322/ 26	238
-	943/555	64	3226200210	347/ 76	223	3226844160	347/411	225	3228304162	322/ 26	238
5951101	347/170	222	3226200250	322/ 67	233	3226844260	347/410	225	3228800024	347/321	222
7200416	381/ 14	203	3226200350	322/ 66	233	3226860020	347/223	225	3228800041	322/ 99	230
7200616	381/ 14	203	3226200765	322/ 65	233	3226860102	347/222	225	3228800044	347/142	218
7230035	941/173	128	3226200823	322/157	236	3226860420	347/223	225	3228800124	347/320	222
7230135	941/172	128	3226201004	322/108	231	3226860520	347/222	225	3228800141	322/ 98	230
7250002	943/175	62	3226201923	322/156	236	3227200035	347/181	220	3228800144	347/141	218
7250102	943/174	62	3226204009	322/161	235	3227200135	347/180	220	3228800160	347/138	218
7601359	973/195	165	3226204109	322/160	235	3227200216	347/ 9	220	3228800228	347/134	218
0008850024	210/ 75	6	3226221135	322/ 60	237	3227200237	347/ 7	220	3228800328	347/133	218
15406270	943/651	-	3226221435	322/157	236	3227200337	347/ 6	220	3228800660	347/139	218
15406370	943/650	-	3226221535	322/156	236	3227200637	347/ 5	220	3228800670	322/ 90	230
1129700301	347/ 13	221	3226260909	322/ 64	233	3227200737	347/ 4	220	3228800870	322/ 90	230
1129700401	347/ 12	221	3226270004	322/107	234	3227200805	347/ 3	219	3228801156	322/140	231
3087600159	347/208	219	3226270029	347/165	222	3227200905	347/ 2	219	3228801317	322/201	235
3097200031	347/183	220	3226270104	322/106	234	3227250002	347/175	220	3228801417	322/200	235
3097200131	347/182	220	3226270129	347/164	222	3227250102	347/174	220	3228801456	347/142	218
3127200355	347/ 10	221	3226270535	347/100	222	3227250202	347/175	220	3228801517	322/201	233
3127200455	347/ 11	221	3226271801	322/163	23235	3227250302	347/174	220	3228801556	347/141	218
3127200730	347/ 15	221	3226271804	322/107	234	3227271671	347/ 17	221	3228801617	322/200	233

Mercedes-Benz / Covind

Cod. Originale O.E.M. Ref. Oe Nummer	Cod. Covind Covind Ref. Covind teilnummer	Pagina Page Seite	Cod. Originale O.E.M. Ref. Oe Nummer	Cod. Covind Covind Ref. Covind teilnummer	Pagina Page Seite	Cod. Originale O.E.M. Ref. Oe Nummer	Cod. Covind Covind Ref. Covind teilnummer	Pagina Page Seite	Cod. Originale O.E.M. Ref. Oe Nummer	Cod. Covind Covind Ref. Covind teilnummer	Pagina Page Seite
3228801770	322/ 90	228	3476276901	347/162	222	3816200004	381/100	200	3816473009	381/247	204
3228802317	322/205	235	3476475007	347/315	226	3816200035	381/157	204	3816473109	381/246	204
3228802417	322/204	235	3478805156	347/135	218	3816200104	381/105	211	3816500003	381/750	207
3228802770	322/ 95	228	3478805606	347/201	222	3816200135	381/156	204	3816500103	381/700	207
3316147025	347/231	224	3478805706	347/200	222	3816200313	381/ 73	200	3816570009	381/365	207
3316147125	347/230	224	3478805806	347/205	222	3816200404	381/131	200	3816570209	381/370	207
3317207255	347/ 11	221	3478805906	347/204	222	3816200413	381/ 72	200	3816600206	381/241	204
3317207355	347/ 10	221	3478807270	347/ 90	216	3816200504	381/130	200	3816600306	381/240	204
3318100018	347/147	217	3478807541	347/ 99	216	3816200713	381/ 73	200	3816600314	381/223	204
3318807056	347/142	218	3478807641	347/ 98	216	3816200813	381/ 72	200	3816600326	381/218	204
3318807156	347/141	218	3523100053	347/ 97	216	3816210025	381/ 77	200	3816601028	381/220	-
3355001127	347/110	-	3523100109	347/ 95	216	3816210125	381/ 76	200	3816601128	381/222	-
3355001527	347/110	-	3523100153	347/ 96	216	3816210325	381/ 77	200	3816660028	381/217	204
3376205665	347/ 64	222	3528370042	347/375	226	3816210425	381/ 76	200	3816660128	381/216	204
3376407009	347/247	234	3816000605	381/900	198	3816220235	381/104	200	3816660228	381/219	204
3376407109	347/246	234	3816000705	381/910	210	3816270009	381/100	200	3816660414	381/225	204
3376575509	347/370	-	3816000805	381/950	198	3816270509	381/131	200	3816710020	381/810	206
3377505402	347/145	217	3816000905	381/960	210	3816270609	381/130	200	3816840860	381/475	212
3378805259	347/136	218	3816001005	381/950	198	3816271409	381/104	200	3816841460	381/446	206
3378805364	347/137	218	3816001401	381/905	-	3816271709	381/120	-	3816841560	381/449	212
3378807556	347/140	218	3816001601	381/955	-	3816280272	381/165	200	3816841760	381/451	206
3417507402	347/150	217	3816003405	381/900	198	3816280372	381/164	200	3816841860	381/450	206
3446400350	347/316	226	3816003805	381/905	-	3816400002	381/840	207	3816841960	381/453	212
3466475007	347/315	226	3816003905	381/910	210	3816400009	381/261	204	3816842460	381/452	212
3476205165	347/ 65	222	3816004005	381/950	198	3816400102	381/815	207	3816842560	381/470	206
3476205250	347/ 67	222	3816004105	381/960	210	3816400109	381/260	204	3816842660	381/472	212
3476205310	347/ 77	223	3816100068	381/825	206	3816401202	381/840	207	3816844260	381/448	212
3476205350	347/ 66	222	3816100168	381/824	206	3816402109	381/245	204	3816845060	381/447	206
3476205410	347/ 76	223	3816100268	381/821	212	3816402209	381/244	204	3816845160	381/448	212
3476205450	347/ 67	222	3816100368	381/820	212	3816420102	381/185	204	3816848660	381/447	206
3476205550	347/ 66	222	3816100468	381/831	212	3816420202	381/184	204	3817200005	381/ 3	201
3476206225	347/ 75	223	3816100568	381/830	212	3816470009	381/261	204	3817200037	381/ 18	203
3476206325	347/ 74	223	3816110320	381/ 85	204	3816470109	381/260	204	3817200105	381/ 2	201
3476208509	347/161	222	3816110420	381/ 84	204	3816470209	381/300	207	3817200237	381/ 19	203
3476208609	347/160	222	3816110520	381/ 83	204	3816470409	381/247	204	3817200705	381/ 3	201
3476276801	347/163	222	3816110620	381/ 82	204	3816470509	381/246	204	3817200805	381/ 2	201

Cod. Originale O.E.M. Ref. Oe Nummer	Cod. Covind Covind Ref. Covind teilnummer	Pagina Page Seite	Cod. Originale O.E.M. Ref. Oe Nummer	Cod. Covind Covind Ref. Covind teilnummer	Pagina Page Seite	Cod. Originale O.E.M. Ref. Oe Nummer	Cod. Covind Covind Ref. Covind teilnummer	Pagina Page Seite	Cod. Originale O.E.M. Ref. Oe Nummer	Cod. Covind Covind Ref. Covind teilnummer	Pagina Page Seite
3817201305	381/ 9	201	3818800906	381/320	207	6017200746	207/174	-	6416600101	641/240	189
3817201405	381/ 8	201	3818801870	381/ 88	-	6018800040	207/133	35	6416660028	649/210	-
3817220009	381/ 7	201	3818802006	381/205	205	6018800140	207/132	35	6416661425	641/250	189
3817226109	381/ 6	201	3818802106	381/204	205	6018800183	207/145	35	6416661525	641/251	189
3817230020	381/ 14	203	3818802606	381/201	205	6018850203	207/ 87	36	6416700039	641/800	187
3817230201	381/181	203	3818802706	381/200	205	6018850303	207/ 86	36	6417200005	649/ 3	-
3817230301	381/180	203	3818807406	381/201	205	6018880023	207/130	35	6417200105	649/ 2	-
3817250002	381/175	203	3818807506	381/200	205	6117200205	207/ 3	-	6417200246	641/175	188
3817250060	347/196	221	3818807806	381/205	205	6117200305	207/ 2	-	6417200346	641/174	188
3817250102	381/174	203	3818807906	381/204	205	6117500009	207/140	35	6417201171	641/ 11	188
3817270071	381/ 13	202	3818810201	381/325	-	6205410303	641/619	190	6417201271	641/ 10	188
3817270171	381/ 12	202	3818810301	381/324	-	6316200334	100/110	46	6417230088	641/170	188
3817500014	381/141	200	3818812901	381/315	207	6317500402	100/108	46	6417500618	641/145	187
3817500402	381/140	200	3818813001	381/314	207	6318801270	100/ 90	-	6417501009	641/140	187
3817500409	381/108	200	3818815901	381/207	-	6318801370	100/ 95	-	6417510118	641/155	187
3817500502	381/145	200	3818816001	381/206	-	6318850425	100/237	46	6417510218	641/150	187
3817500509	381/110	200	3818830132	381/ 91	199	6318850525	100/236	46	6417600259	641/195	188
3817500709	381/108	200	3818850008	381/ 90	199	6383100826	108/ 96	-	6417600359	641/194	188
3817500809	381/109	211	3818850808	381/ 89	-	6387200046	108/165	43	6418800236	641/ 96	186
3817500909	381/110	200	3818990208	381/ 92	-	6387200146	108/164	43	6418800238	641/ 96	186
3817501302	381/145	200	3818990408	381/ 93	199	6387500002	108/140	42	6418800270	641/ 90	186
3817501402	381/150	211	3837500002	381/110	200	6387580181	108/135	-	6418800473	641/ 94	186
3817600059	381/ 16	202	3854205168	381/620	208	6388800483	108/130	42	6418803770	641/ 91	186
3817660001	381/196	202	3854260465	381/619	208	6388801006	108/201	42	6418806270	641/ 95	186
3817660043	381/170	202	3873170423	381/ 98	199	6388801206	108/200	42	6418806370	641/ 94	186
3817660901	381/196	202	3896710020	389/815	-	6388801406	108/201	42	6418809970	641/ 95	186
3818112510	381/500	-	3897500002	389/145	-	6388801506	108/200	42	6418810201	641/201	189
3818200212	381/ 96	199	4258150236	381/111	200	6388880415	108/130	42	6418810301	641/200	189
3818205161	641/781	-	6013101622	207/110	34	6415200806	641/781	-	6418810401	641/205	189
3818205261	641/782	-	6015201370	207/ 90	34	6415200906	641/782	-	6418810501	641/204	189
3818260089	381/ 96	199	6015201570	207/ 95	34	6416200036	641/163	187	6418810601	641/321	-
3818800003	381/ 87	-	6015203941	207/100	34	6416200136	641/162	187	6418810701	641/320	-
3818800070	381/ 95	199	6016200024	207/201	35	6416200136	649/165	179	6418810801	641/325	-
3818800103	381/ 86	-	6016200124	207/200	35	6416201436	649/161	179	6418810901	641/324	-
3818800170	381/ 94	199	6016710020	207/800	-	6416201536	649/160	179	6418811001	641/203	189
3818800806	381/321	207	6017200646	207/175	-	6416600001	641/241	189	6418811101	641/202	189

Mercedes-Benz / Covind

Cod. Originale O.E.M. Ref. Oe Nummer	Cod. Covind Covind Ref. Covind teilnummer	Pagina Page Seite	Cod. Originale O.E.M. Ref. Oe Nummer	Cod. Covind Covind Ref. Covind teilnummer	Pagina Page Seite	Cod. Originale O.E.M. Ref. Oe Nummer	Cod. Covind Covind Ref. Covind teilnummer	Pagina Page Seite	Cod. Originale O.E.M. Ref. Oe Nummer	Cod. Covind Covind Ref. Covind teilnummer	Pagina Page Seite
6418811401	641/317	-	6736710120	673/800	174	9018202461	209/757	15	9068801171	209/ 84	18
6418811501	641/316	-	6737500002	670/140	-	9018202561	209/756	15	9068850011	210/105	6
6418816901	641/199	189	6738800170	670/ 90	174	9018600053	209/ 98	-	9068850053	209/106	-
6418817001	641/198	189	8272201300	108/ 95	42	9018800103	209/145	15	9068850053	210/106	6
6418817101	641/211	189	8272201400	108/ 94	42	9018800114	209/100	14	9068850075	210/ 88	6
6418817201	641/210	189	9013100522	208/ 96	-	9018800151	208/145	28	9305200007	943/525	64
6418817301	641/215	189	9013100722	209/ 96	14	9018800183	208/130	28	9305200019	943/517	64
6418817401	641/214	189	9016306907	209/201	15	9018800270	208/ 90	27	9305200020	943/519	64
6418817701	641/327	-	9016307007	209/200	15	9018800314	209/ 87	-	9305200119	943/516	64
6418817801	641/326	-	9016370240	209/511	18	9018800351	208/145	28	9305200120	943/518	64
6418817901	641/329	-	9016370340	209/510	18	9018800371	208/ 85	30	9305200195	943/543	-
6418818001	641/328	-	9016373001	208/201	28	9018800385	209/130	15	9305200207	943/520	64
6496200136	649/165	179	9016373101	208/200	28	9018800471	208/ 84	30	9305200419	943/530	64
6496200236	649/164	179	9016710020	208/800	-	9018800670	209/ 90	14	9305210097	943/540	-
6496600006	649/241	181	9017200066	209/171	16	9018800770	209/105	14	9305210197	943/541	-
6496600106	649/240	181	9017200166	209/170	16	9018800870	209/ 95	14	9406660128	940/212	147
6496700039	649/800	179	9017201135	209/186	16	9018850102	208/ 86	-	9406660428	940/210	147
6497500109	649/140	179	9017201146	208/167	29	9018850202	208/ 81	30	9406662101	940/201	147
6497500118	649/150	179	9017201235	209/187	16	9018880173	209/120	15	9406662201	940/200	147
6497510018	649/145	179	9017201246	208/166	29	9043100322	208/ 96	27	9406662401	940/241	147
6498800070	649/ 95	178	9017201446	209/175	16	9048820201	209/520	19	9406662501	940/240	147
6498800136	649/ 98	178	9017201546	209/174	16	9066200024	210/120	7	9415200119	941/519	129
6498810001	649/201	181	9017301135	209/192	17	9066200234	210/ 96	6	9415200120	941/523	129
6498810101	649/200	181	9017400135	209/193	18	9066377719	210/201	7	9415200219	941/518	129
6498810201	649/321	181	9017500002	208/140	28	9066377819	210/200	7	9415200220	941/522	129
6498810301	649/320	181	9017500202	209/150	15	9067500002	210/140	7	9415200320	941/523	129
6625200019	641/520	190	9017500302	209/135	15	9068200561	210/757	7	9415201620	941/522	129
6625200219	641/510	190	9017600302	209/196	-	9068200661	210/756	7	9415207441	943/544	-
6625200319	641/515	190	9017600402	209/197	16	9068260040	210/511	8	9415220004	941/520	129
6706710020	670/805	174	9017600459	209/190	17	9068260140	210/510	8	9415220067	941/515	129
6707600159	381/196	202	9017600502	209/198	16	9068800170	210/ 90	6	9415220167	943/515	64
6708301042	381/375	207	9017601047	209/182	17	9068800370	210/100	-	9415410103	941/619	130
6736280072	670/165	174	9017601347	209/185	17	9068800385	210/130	7	9416600201	941/241	126
6736280172	670/164	174	9017601361	209/180	17	9068800570	210/ 95	6	9416600301	941/240	126
6736600201	670/241	174	9018200161	209/755	-	9068800770	210/110	-	9416660201	941/241	126
6736600301	670/240	174	9018200261	209/754	-	9068801071	209/ 85	18	9416660301	941/240	126

Cod. Originale O.E.M. Ref. Oe Nummer	Cod. Covind Covind Ref. Covind teilnummer	Pagina Page Seite	Cod. Originale O.E.M. Ref. Oe Nummer	Cod. Covind Covind Ref. Covind teilnummer	Pagina Page Seite	Cod. Originale O.E.M. Ref. Oe Nummer	Cod. Covind Covind Ref. Covind teilnummer	Pagina Page Seite	Cod. Originale O.E.M. Ref. Oe Nummer	Cod. Covind Covind Ref. Covind teilnummer	Pagina Page Seite
9416661901	944/201	136	9418801670	941/ 96	122	9436660837	943/207	61	9438804573	943/ 92	69
9416662001	944/200	136	9418802370	941/ 95	122	9436660901	943/248	74	9438806072	943/ 79	56
9416662101	944/241	136	9418802470	941/ 94	122	9436660937	943/206	61	9438806172	943/ 78	56
9416662201	944/240	136	9418802770	944/ 95	132	9436662601	943/251	74	9438806272	943/ 53	50
9416662601	944/241	136	9418802870	944/ 94	132	9436662701	943/250	74	9438806372	943/ 52	50
9416662701	944/240	136	9418840222	941/161	125	9436663801	944/201	136	9438807470	943/ 94	105
9416663328	944/212	136	9418840222	941/165	-	9436663901	944/200	136	9438807570	943/ 95	105
9416663428	944/215	136	9418840322	941/160	125	9436664301	943/244	74	9438807672	943/ 51	50
9416663528	944/216	136	9418840322	941/164	-	9437500009	943/140	95	9438807772	943/ 50	50
9416663728	944/211	136	9418840422	941/151	125	9437500218	943/150	95	9438808070	943/102	82
9416663828	944/210	136	9418840522	941/150	125	9437500518	943/145	-	9438808170	943/101	82
9417200066	943/173	62	9418841122	941/153	125	9438200161	943/601	-	9438809870	943/ 94	105
9417200166	943/172	62	9418841222	941/152	125	9438200261	943/600	-	9438809872	943/ 87	82
9417200348	943/ 5	76	9418841422	941/155	125	9438800004	943/ 93	69	9438830001	943/ 91	-
9417200446	941/175	128	9418841522	941/154	125	9438800070	943/102	82	9438840023	943/161	95
9417200448	943/ 4	76	9418851301	941/ 87	132	9438800073	943/ 83	88	9438840074	943/125	94
9417200546	941/174	128	9418851401	941/ 90	122	9438800104	943/ 92	69	9438840123	943/160	95
9417280856	943/ 7	76	9418853422	941/125	122	9438800170	943/101	82	9438840174	943/124	94
9417280956	943/ 6	76	9418853522	941/124	122	9438800173	943/ 82	88	9438840223	943/155	95
9417500009	941/140	125	9418853822	941/120	122	9438800270	943/ 87	82	9438840323	943/154	95
9417511018	941/145	125	9418900472	943/451	97	9438800370	943/ 86	82	9438840623	943/153	95
9417511218	941/145	125	9418900572	943/450	97	9438800370	943/ 86	82	9438840723	943/152	95
9417600102	941/197	128	9436600601	943/243	61	9438800473	943/ 67	53	9438841722	943/165	60
9417600459	941/149	120	9436600701	943/242	61	9438800573	943/ 66	53	9438841822	943/164	60
9417600550	941/148	120	9436600801	943/241	61	9438800601	943/243	61	9438841922	943/163	60
9417600559	941/148	120	9436600901	943/240	61	9438800670	943/ 83	88	9438842022	943/162	60
9418204761	941/601	-	9436601001	943/205	61	9438800770	943/ 82	88	9438850025	943/ 77	94
9418204861	941/600	-	9436601101	943/204	61	9438801470	943/ 57	53	9438850125	943/ 76	94
9418206161	941/601	-	9436660005	943/238	61	9438801570	943/ 56	53	9438850201	943/ 88	56
9418206261	941/600	-	9436660005	943/238	61	9438803570	943/ 55	91	9438850222	943/ 99	50
9418800225	941/ 89	132	9436660028	943/215	-	9438803670	943/ 54	91	9438850225	943/ 75	94
9418800325	941/ 88	132	9436660401	943/245	74	9438803873	973/ 71	69	9438850301	943/ 90	69
9418800344	941/167	125	9436660501	943/244	74	9438803970	943/ 49	91	9438850322	943/ 98	50
9418800444	941/166	125	9436660637	943/209	61	9438803973	943/ 70	105	9438850325	943/ 85	94
9418800970	941/ 93	122	9436660737	943/208	61	9438804070	943/ 48	91	9438850326	943/100	105
9418801070	941/ 92	122	9436660801	943/249	74	9438804473	943/ 93	69	9438850374	943/120	94

Mercedes-Benz / Covind

Cod. Originale O.E.M. Ref. Oe Nummer	Cod. Covind Covind Ref. Covind teilnummer	Pagina Page Seite	Cod. Originale O.E.M. Ref. Oe Nummer	Cod. Covind Covind Ref. Covind teilnummer	Pagina Page Seite	Cod. Originale O.E.M. Ref. Oe Nummer	Cod. Covind Covind Ref. Covind teilnummer	Pagina Page Seite	Cod. Originale O.E.M. Ref. Oe Nummer	Cod. Covind Covind Ref. Covind teilnummer	Pagina Page Seite
9438850374	943/122	-	9705253439	973/ 89	162	Iveco					
9438850422	943/ 97	82	9705253439	973/ 93	-	2993918	240/677	130			
9438850425	943/ 84	94	9705253539	973/ 88	162	41003248	240/677	130			
9438850426	943/ 89	56	9705253539	973/ 92	-	41012699	240/675	130			
9438850522	943/ 96	82	9736661428	973/210	163	41042699	240/675	130			
9438850525	943/ 80	94	9736661528	973/212	163	98497821	240/675	130			
9438850922	943/114	53	9736661628	973/211	163						
9438851022	943/113	53	9736662701	973/201	164	Man					
9438851122	943/105	53	9736663001	973/200	164	4711230	M20/670	130			
9438851125	943/112	53	9736663101	973/207	163						
9438851222	943/107	53	9736663201	973/206	163	Volvo					
9438851225	943/111	53	9736663301	973/205	164	9520400	0FH/670	130			
9438851322	943/106	53	9736663601	973/204	164						
9438851325	943/110	53	9737200146	973/175	165						
9438851422	943/104	53	9737200246	973/174	165						
9438851522	943/103	53	9737200346	973/165	165						
9438851625	943/117	53	9737200446	973/164	165						
9438851725	943/116	53	9737200735	941/177	128						
9438851825	943/115	53	9737200835	941/176	128						
9445220167	641/525	190	9737201705	973/ 3	-						
9446660101	940/243	147	9737201805	973/ 2	-						
9446660201	940/242	147	9737500602	973/140	-						
9446661301	940/205	147	9738110410	973/500	-						
9446661401	940/204	147	9738800005	973/155	-						
9448800104	940/ 94	144	9738800105	973/154	-						
9448800270	940/ 91	-	9738800470	973/ 85	162						
9448800370	940/ 90	-	9738800570	973/ 84	162						
9448802404	940/ 93	144	9738801070	973/ 80	162						
9448830001	940/ 97	-	9738801170	973/ 90	162						
9448830101	940/ 96	-	9738801670	973/ 95	162						
9448850125	940/ 86	144	9738801770	973/ 94	162						
9448850525	940/ 83	144	9738840105	973/145	-						
9448850625	940/ 82	144	9738840123	973/161	169						
9448850725	940/ 87	144	9738840185	973/145	-						
9586662001	940/204	147	9738840223	973/160	169						
9586662101	940/205	147									

Cod. Covind Covind Ref. Covind teilnummer	Cod. Originale O.E.M. Ref. Oe Nummer	Pagina Page Seite	Cod. Covind Covind Ref. Covind teilnummer	Cod. Originale O.E.M. Ref. Oe Nummer	Pagina Page Seite	Cod. Covind Covind Ref. Covind teilnummer	Cod. Originale O.E.M. Ref. Oe Nummer	Pagina Page Seite	Cod. Covind Covind Ref. Covind teilnummer	Cod. Originale O.E.M. Ref. Oe Nummer	Pagina Page Seite
100/ 90	6318801270	-	207/800	6016710020	-	209/180	9017601361	17	210/756	9068200661	7
100/ 95	6318801370	-	208/ 81	9018850202	30	209/182	9017601047	17	210/757	9068200561	7
100/108	6317500402	46	208/ 84	9018800471	30	209/185	9017601347	17	322/ 26	3228301662	238
100/110	6316200334	46	208/ 85	9018800371	30	209/186	9017201135	16	322/ 26	3228303562	238
100/236	6318850525	46	208/ 86	9018850102	-	209/187	9017201235	16	322/ 26	3228304162	238
100/237	6318850425	46	208/ 90	9018800270	27	209/190	9017600459	17	322/ 60	3226221135	239
108/ 94	8272201400	42	208/ 96	9043100322	27	209/192	9017301135	17	322/ 64	3226260909	235
108/ 95	8272201300	42	208/ 96	9013100522	-	209/193	9017400135	18	322/ 65	3226200765	235
108/ 96	6383100826	-	208/130	9018800183	28	209/196	9017600302	-	322/ 66	3226200350	235
108/130	6388800483	42	208/140	9017500002	28	209/197	9017600402	16	322/ 67	3226200250	235
108/130	6388880415	42	208/145	9018800151	28	209/198	9017600502	16	322/ 90	3228800670	230
108/135	6387580181	-	208/145	9018800351	28	209/200	9016307007	15	322/ 90	3228800870	230
108/140	6387500002	42	208/166	9017201246	29	209/201	9016306907	15	322/ 90	3228801770	230
108/164	6387200146	43	208/167	9017201146	29	209/510	9016370340	18	322/ 95	3228802770	230
108/165	6387200046	43	208/200	9016373101	28	209/511	9016370240	18	322/ 98	3228800141	230
108/200	6388801506	42	208/201	9016373001	28	209/520	9048820201	19	322/ 99	3228800041	230
108/200	6388801206	42	208/800	9016710020	-	209/754	9018200261	-	322/106	3226270104	236
108/201	6388801406	42	209/ 84	9068801171	18	209/755	9018200161	-	322/106	3226271904	236
108/201	6388801006	42	209/ 85	9068801071	18	209/756	9018202561	15	322/107	3226270004	236
207/ 2	6117200305	-	209/ 87	9018800314	-	209/757	9018202461	15	322/107	3226271804	236
207/ 3	6117200205	-	209/ 90	9018800670	14	210/ 75	0008850024	6	322/108	3226201004	231
207/ 86	6018850303	36	209/ 95	9018800870	14	210/ 88	9068850075	6	322/140	3228801156	231
207/ 87	6018850203	36	209/ 96	9013100722	14	210/ 90	9068800170	6	322/145	3227500902	231
207/ 90	6015201370	34	209/ 98	9018600053	-	210/ 95	9068800570	6	322/156	3226201923	236
207/ 95	6015201570	34	209/100	9018800114	14	210/ 96	9066200234	6	322/156	3226221535	236
207/100	6015203941	34	209/105	9018800770	14	210/100	9068800370	-	322/157	3226200823	236
207/110	6013101622	34	209/106	9068850053	-	210/105	9068850011	6	322/157	3226221435	236
207/130	6018880023	35	209/120	9018880173	15	210/106	9068850053	6	322/160	3226204109	235
207/132	6018800140	35	209/130	9018800385	15	210/110	9068800770	-	322/161	3226204009	235
207/133	6018800040	35	209/135	9017500302	15	210/120	9066200024	7	322/162	3226271901	235
207/140	6117500009	35	209/145	9018800103	15	210/130	9068800385	7	322/163	3226271801	235
207/145	6018800183	35	209/150	9017500202	15	210/140	9067500002	7	322/184	3226104610	238
207/174	6017200746	-	209/170	9017200166	16	210/200	9066377819	7	322/185	3226104510	238
207/175	6017200646	-	209/171	9017200066	16	210/201	9066377719	7	322/200	3228801417	235
207/200	6016200124	35	209/174	9017201546	16	210/510	9068260140	8	322/200	3228801617	235
207/201	6016200024	35	209/175	9017201446	16	210/511	9068260040	8	322/201	3228801317	235

Covind / Mercedes-Benz

Cod. Covind Covind Ref. Covind teilnummer	Cod. Originale O.E.M. Ref. Oe Nummer	Pagina Page Seite	Cod. Covind Covind Ref. Covind teilnummer	Cod. Originale O.E.M. Ref. Oe Nummer	Pagina Page Seite	Cod. Covind Covind Ref. Covind teilnummer	Cod. Originale O.E.M. Ref. Oe Nummer	Pagina Page Seite	Cod. Covind Covind Ref. Covind teilnummer	Cod. Originale O.E.M. Ref. Oe Nummer	Pagina Page Seite
322/201	3228801517	235	347/ 67	3476205250	222	347/145	3377505402	217	347/215	3226660532	224
322/204	3228802417	235	347/ 67	3476205450	222	347/147	3198100118	217	347/217	3226120134	224
322/205	3228802317	235	347/ 72	3228300862	223	347/147	3318100018	217	347/222	3226860102	225
322/246	3226403609	236	347/ 73	3228300762	223	347/150	3417507402	217	347/222	3226860520	225
322/247	3226403509	236	347/ 74	3476206325	223	347/160	3476208609	222	347/223	3226860020	225
322/248	3226461028	-	347/ 75	3476206225	223	347/161	3476208509	222	347/223	3226860420	225
322/249	3226460928	-	347/ 76	3226200210	223	347/162	3476276901	222	347/230	3226140125	224
322/370	3226570009	239	347/ 76	3476205410	223	347/163	3476276801	222	347/230	3316147125	224
347/ 2	3227200905	219	347/ 77	3226200110	223	347/164	3226270129	222	347/231	3226140025	224
347/ 3	3227200805	219	347/ 77	3476205310	223	347/165	3226270029	222	347/231	3316147025	224
347/ 4	3227200737	220	347/ 78	3228300343	223	347/170	5951101	222	347/246	3376407109	234
347/ 5	3227200637	220	347/ 79	3228300243	223	347/174	3227250102	220	347/247	3376407009	234
347/ 6	3227200337	220	347/ 90	3478807270	216	347/174	3227250302	220	347/315	3226400950	226
347/ 7	3227200237	220	347/ 95	3523100109	216	347/175	3227250002	220	347/315	3226470207	226
347/ 9	3227200216	220	347/ 96	3523100153	216	347/175	3227250202	220	347/315	3226470307	226
347/ 10	3127200355	221	347/ 97	3523100053	216	347/180	3227200135	220	347/315	3466475007	226
347/ 10	3317207355	221	347/ 98	3478807641	216	347/181	3127230035	220	347/315	3476475007	226
347/ 11	3127200455	221	347/ 99	3478807541	216	347/181	3127230101	220	347/316	3446400350	226
347/ 11	3317207255	221	347/100	3196270035	222	347/181	3227200035	220	347/320	3228800124	222
347/ 12	1129700401	221	347/100	3226270535	222	347/182	3097200131	220	347/321	3228800024	222
347/ 13	1129700301	221	347/110	3355001127	-	347/183	3097200031	220	347/370	3376575509	-
347/ 14	3127200830	221	347/110	3355001527	-	347/190	3227660301	219	347/372	-	226
347/ 15	3127200730	221	347/133	3228800328	218	347/194	3227600161	220	347/375	3528370042	226
347/ 16	3227271771	221	347/134	3228800228	218	347/195	3227600061	220	347/410	3226844060	225
347/ 17	3227271671	221	347/135	3478805156	218	347/196	3127680002	221	347/410	3226844260	225
347/ 20	3226123014	225	347/136	3378805259	218	347/196	3147600102	221	347/411	3226843960	225
347/ 25	3148110114	219	347/137	3378805364	218	347/196	3817250060	221	347/411	3226844160	225
347/ 25	3148110514	219	347/138	3228800160	218	347/198	3227660701	219	381/ 2	3817200105	201
347/ 25	3228100013	219	347/139	3228800660	218	347/200	3478805706	222	381/ 2	3817200805	201
347/ 25	3228110214	219	347/140	3378807556	218	347/201	3478805606	222	381/ 3	3817200005	201
347/ 25	3228111914	219	347/141	3228800144	218	347/204	3478805906	222	381/ 3	3817200705	201
347/ 25	3228112004	219	347/141	3228801556	218	347/205	3478805806	222	381/ 4	-	-
347/ 64	3376205665	222	347/141	3318807156	218	347/208	3087600159	219	381/ 6	3817226109	201
347/ 65	3476205165	222	347/142	3228800044	218	347/212	3226660128	224	381/ 7	3817220009	201
347/ 66	3476205350	222	347/142	3228801456	218	347/213	3226660028	224	381/ 8	3817201405	201
347/ 66	3476205550	222	347/142	3318807056	218	347/215	3226660432	224	381/ 9	3817201305	201

Cod. Covind Covind Ref. Covind teilnummer	Cod. Originale O.E.M. Ref. Oe Nummer	Pagina Page Seite	Cod. Covind Covind Ref. Covind teilnummer	Cod. Originale O.E.M. Ref. Oe Nummer	Pagina Page Seite	Cod. Covind Covind Ref. Covind teilnummer	Cod. Originale O.E.M. Ref. Oe Nummer	Pagina Page Seite	Cod. Covind Covind Ref. Covind teilnummer	Cod. Originale O.E.M. Ref. Oe Nummer	Pagina Page Seite
381/ 10	-	201	381/104	3816220235	200	381/201	3818802606	205	381/370	3816570209	207
381/ 12	3817270171	202	381/104	3816271409	200	381/201	3818807406	205	381/375	6708301042	207
381/ 13	3817270071	202	381/105	3816200104	211	381/204	3818802106	205	381/446	3816841460	206
381/ 14	7200416	203	381/108	3817500409	200	381/204	3818807906	205	381/447	3816845060	206
381/ 14	7200616	203	381/108	3817500709	200	381/205	3818802006	205	381/447	3816848660	206
381/ 14	3817230020	203	381/109	3817500809	211	381/205	3818807806	205	381/448	3816844260	212
381/ 16	3817600059	202	381/110	3817500509	200	381/206	3818816001	-	381/448	3816845160	212
381/ 18	3817200037	203	381/110	3817500909	200	381/207	3818815901	-	381/449	3816841560	212
381/ 19	3817200237	203	381/110	3837500002	200	381/216	3816660128	204	381/450	3816841860	206
381/ 72	3816200413	200	381/111	4258150236	200	381/217	3816660028	204	381/451	3816841760	206
381/ 72	3816200813	200	381/120	3816271709	-	381/218	3816600326	204	381/452	3816842460	212
381/ 73	3816200313	200	381/130	3816200504	200	381/219	3816660228	204	381/453	3816841960	212
381/ 73	3816200713	200	381/130	3816270609	200	381/220	3816601028	-	381/470	3816842560	206
381/ 76	3816210125	200	381/131	3816200404	200	381/222	3816601128	-	381/472	3816842660	212
381/ 76	3816210425	200	381/131	3816270509	200	381/223	3816600314	204	381/475	3816840860	212
381/ 77	3816210025	200	381/140	3817500402	200	381/225	3816660414	204	381/500	3818112510	-
381/ 77	3816210325	200	381/141	3817500014	200	381/240	3816600306	204	381/619	3854260465	208
381/ 82	3816110620	204	381/145	3817500502	200	381/241	3816600206	204	381/620	3854205168	208
381/ 83	3816110520	204	381/145	3817501302	200	381/244	3816402209	204	381/700	3816500103	207
381/ 84	3816110420	204	381/150	3817501402	211	381/245	3816402109	204	381/750	3816500003	207
381/ 85	3816110320	204	381/156	3816200135	204	381/246	3816470509	204	381/810	3816710020	206
381/ 86	3818800103	-	381/157	3816200035	204	381/246	3816473109	204	381/815	3816400102	207
381/ 87	3818800003	-	381/164	3816280372	200	381/247	3816470409	204	381/820	3816100368	212
381/ 88	3818801870	-	381/165	3816280272	200	381/247	3816473009	204	381/821	3816100268	212
381/ 89	3818850808	-	381/170	3817660043	202	381/260	3816400109	204	381/824	3816100168	206
381/ 90	3818850008	199	381/174	3817250102	203	381/260	3816470109	204	381/825	3816100068	206
381/ 91	3818830132	199	381/175	3817250002	203	381/261	3816400009	204	381/830	3816100568	212
381/ 92	3818990208	-	381/180	3817230301	203	381/261	3816470009	204	381/831	3816100468	212
381/ 93	3818990408	199	381/181	3817230201	203	381/300	3816470209	207	381/840	3816400002	207
381/ 94	3818800170	199	381/184	3816420202	204	381/314	3818813001	207	381/840	3816401202	207
381/ 95	3818800070	199	381/185	3816420102	204	381/315	3818812901	207	381/900	3816000605	198
381/ 96	3818200212	199	381/196	3817660001	202	381/320	3818800906	207	381/900	3816003405	198
381/ 96	3818260089	199	381/196	3817660901	202	381/321	3818800806	207	381/905	3816001401	-
381/ 98	3873170423	199	381/196	6707600159	202	381/324	3818810301	-	381/905	3816003805	-
381/100	3816200004	200	381/200	3818802706	205	381/325	3818810201	-	381/910	3816000705	210
381/100	3816270009	200	381/200	3818807506	205	381/365	3816570009	207	381/910	3816003905	210

Covind / Mercedes-Benz

Cod. Covind Covind Ref. Covind teilnummer	Cod. Originale O.E.M. Ref. Oe Nummer	Pagina Page Seite	Cod. Covind Covind Ref. Covind teilnummer	Cod. Originale O.E.M. Ref. Oe Nummer	Pagina Page Seite	Cod. Covind Covind Ref. Covind teilnummer	Cod. Originale O.E.M. Ref. Oe Nummer	Pagina Page Seite	Cod. Covind Covind Ref. Covind teilnummer	Cod. Originale O.E.M. Ref. Oe Nummer	Pagina Page Seite
381/915	-	-	641/202	6418811101	189	649/140	6497500109	179	940/ 90	9448800370	-
381/950	3816000805	198	641/203	6418811001	189	649/145	6497510018	179	940/ 91	9448800270	-
381/950	3816001005	198	641/204	6418810501	189	649/150	6497500118	179	940/ 93	9448802404	144
381/950	3816004005	198	641/205	6418810401	189	649/160	6416201536	179	940/ 94	9448800104	144
381/955	3816001601	-	641/210	6418817201	189	649/161	6416201436	179	940/ 96	9448830101	-
381/960	3816000905	210	641/211	6418817101	189	649/162	-	179	940/ 97	9448830001	-
381/960	3816004105	210	641/214	6418817401	189	649/163	-	179	940/200	9406662201	147
381/965	-	-	641/215	6418817301	189	649/164	6496200236	179	940/201	9406662101	147
389/145	3897500002	-	641/240	6416600101	189	649/165	6416200136	179	940/204	9446661401	147
389/815	3896710020	-	641/241	6416600001	189	649/165	6496200136	179	940/204	9586662001	147
641/ 10	6417201271	188	641/250	6416661425	189	649/200	6498810101	181	940/205	9446661301	147
641/ 11	6417201171	188	641/251	6416661525	189	649/201	6498810001	181	940/205	9586662101	147
641/ 90	6418800270	186	641/316	6418811501	-	649/210	6416660028	-	940/210	9406660428	147
641/ 91	6418803770	186	641/317	6418811401	-	649/240	6496600106	181	940/212	9406660128	147
641/ 94	6418800473	186	641/320	6418810701	-	649/241	6496600006	181	940/240	9406662501	147
641/ 94	6418806370	186	641/321	6418810601	-	649/320	6498810301	181	940/241	9406662401	147
641/ 95	6418806270	186	641/324	6418810901	-	649/321	6498810201	181	940/242	9446660201	147
641/ 95	6418809970	186	641/325	6418810801	-	649/800	6496700039	179	940/243	9446660101	147
641/ 96	6418800236	186	641/326	6418817801	-	670/ 90	6738800170	174	940/941	-	122
641/ 96	6418800238	186	641/327	6418817701	-	670/140	6737500002	-	941/ 87	9418851301	132
641/140	6417501009	187	641/328	6418818001	-	670/164	6736280172	174	941/ 88	9418800325	132
641/145	6417500618	187	641/329	6418817901	-	670/165	6736280072	174	941/ 89	9418800225	132
641/150	6417510218	187	641/510	6625200219	190	670/240	6736600301	174	941/ 90	9418851401	122
641/155	6417510118	187	641/515	6625200319	190	670/241	6736600201	174	941/ 92	9418801070	122
641/162	6416200136	187	641/520	6625200019	190	670/805	6706710020	174	941/ 93	9418800970	122
641/163	6416200036	187	641/525	9445220167	190	673/800	6736710120	174	941/ 94	9418802470	122
641/170	6417230088	188	641/619	6205410303	190	930/022	-	63	941/ 95	9418802370	122
641/171	-	-	641/781	3818205161	-	930/023	-	63	941/ 96	9418801670	122
641/174	6417200346	188	641/781	6415200806	-	930/032	-	63	941/120	9418853822	122
641/175	6417200246	188	641/782	3818205261	-	930/122	-	63	941/124	9418853522	122
641/194	6417600359	188	641/782	6415200906	-	930/123	-	63	941/125	9418853422	122
641/195	6417600259	188	641/800	6416700039	187	930/132	-	63	941/140	9417500009	125
641/198	6418817001	189	649/ 2	6417200105	-	940/ 82	9448850625	144	941/145	9417511018	125
641/199	6418816901	189	649/ 3	6417200005	-	940/ 83	9448850525	144	941/145	9417511218	125
641/200	6418810301	189	649/ 95	6498800070	178	940/ 86	9448850125	144	941/148	9417600550	120
641/201	6418810201	189	649/ 98	6498800136	178	940/ 87	9448850725	144	941/148	9417600559	120

Cod. Covind Covind Ref. Covind teilnummer	Cod. Originale O.E.M. Ref. Oe Nummer	Pagina Page Seite	Cod. Covind Covind Ref. Covind teilnummer	Cod. Originale O.E.M. Ref. Oe Nummer	Pagina Page Seite	Cod. Covind Covind Ref. Covind teilnummer	Cod. Originale O.E.M. Ref. Oe Nummer	Pagina Page Seite	Cod. Covind Covind Ref. Covind teilnummer	Cod. Originale O.E.M. Ref. Oe Nummer	Pagina Page Seite
941/149	9417600459	120	941/619	9415410103	130	943/ 90	9438850301	69	943/145	9437500518	-
941/150	9418840522	125	943/ 4	9417200448	76	943/ 91	9438830001	-	943/150	9437500218	95
941/151	9418840422	125	943/ 5	9417200348	76	943/ 92	9438800104	69	943/152	9438840723	95
941/152	9418841222	125	943/ 6	9417280956	76	943/ 92	9438804573	69	943/153	9438840623	95
941/153	9418841122	125	943/ 7	9417280856	76	943/ 93	9438800004	69	943/154	9438840323	95
941/154	9418841522	125	943/ 48	9438804070	91	943/ 93	9438804473	69	943/155	9438840223	95
941/155	9418841422	125	943/ 49	9438803970	91	943/ 94	9438807470	105	943/160	9438840123	95
941/160	9418840322	125	943/ 50	9438807772	50	943/ 94	9438809870	105	943/161	9438840023	95
941/161	9418840222	125	943/ 51	9438807672	50	943/ 95	9438807570	105	943/162	9438842022	60
941/164	9418840322	-	943/ 52	9438806372	50	943/ 96	9438850522	82	943/163	9438841922	60
941/165	9418840222	-	943/ 53	9438806272	50	943/ 97	9438850422	82	943/164	9438841822	60
941/166	9418800444	125	943/ 54	9438803670	91	943/ 98	9438850322	50	943/165	9438841722	60
941/167	9418800344	125	943/ 55	9438803570	91	943/ 99	9438850222	50	943/172	9417200166	62
941/172	7230135	128	943/ 56	9438801570	53	943/100	9438850326	105	943/173	9417200066	62
941/173	7230035	128	943/ 57	9438801470	53	943/101	9438800170	82	943/174	7250102	62
941/174	9417200546	128	943/ 66	9438800573	53	943/101	9438808170	82	943/175	7250002	62
941/175	9417200446	128	943/ 67	9438800473	53	943/102	9438800070	82	943/204	9436601101	61
941/176	9737200835	128	943/ 70	9438803973	105	943/102	9438808070	82	943/205	9436601001	61
941/177	9737200735	128	943/ 75	9438850225	105	943/103	9438851522	53	943/206	9436660937	61
941/197	9417600102	128	943/ 76	9438850125	94	943/104	9438851422	53	943/207	9436660837	61
941/240	9416600301	126	943/ 77	9438850025	94	943/105	9438851122	53	943/208	9436660737	61
941/240	9416660301	126	943/ 78	9438806172	56	943/106	9438851322	53	943/209	9436660637	61
941/241	9416600201	126	943/ 79	9438806072	56	943/107	9438851222	53	943/215	9436660028	-
941/241	9416660201	126	943/ 80	9438850525	94	943/110	9438851325	53	943/238	9436660005	61
941/515	9415220067	129	943/ 82	9438800173	88	943/111	9438851225	53	943/238	9436660005	61
941/518	9415200219	129	943/ 82	9438800770	88	943/112	9438851125	53	943/240	9436600901	61
941/519	9415200119	129	943/ 83	9438800073	88	943/113	9438851022	53	943/241	9436600801	61
941/520	9415220004	129	943/ 83	9438800670	88	943/114	9438850922	53	943/242	9436600701	61
941/522	9415200220	129	943/ 84	9438850425	94	943/115	9438851825	53	943/243	9436600601	61
941/522	9415201620	129	943/ 85	9438850325	94	943/116	9438851725	53	943/243	9438800601	61
941/523	9415200120	129	943/ 86	9438800370	82	943/117	9438851625	53	943/244	9436660501	74
941/523	9415200320	129	943/ 86	9438800370	82	943/120	9438850374	94	943/244	9436664301	74
941/600	9418204861	-	943/ 87	9438800270	82	943/122	9438850374	-	943/245	9436660401	74
941/600	9418206261	-	943/ 87	9438809872	82	943/124	9438840174	94	943/248	9436660901	74
941/601	9418204761	-	943/ 88	9438850201	56	943/125	9438840074	94	943/249	9436660801	74
941/601	9418206161	-	943/ 89	9438850426	56	943/140	9437500009	95	943/250	9436662701	74

Covind / Mercedes-Benz

Cod. Covind Covind Ref. Covind teilnummer	Cod. Originale O.E.M. Ref. Oe Nummer	Pagina Page Seite	Cod. Covind Covind Ref. Covind teilnummer	Cod. Originale O.E.M. Ref. Oe Nummer	Pagina Page Seite	Cod. Covind Covind Ref. Covind teilnummer	Cod. Originale O.E.M. Ref. Oe Nummer	Pagina Page Seite	Cod. Covind Covind Ref. Covind teilnummer	Cod. Originale O.E.M. Ref. Oe Nummer	Pagina Page Seite
943/251	9436662601	74	973/ 2	9737201805	-	Iveco					
943/450	9418900572	97	973/ 3	9737201705	-	240/675	41012699	130			
943/451	9418900472	97	973/ 71	9438803873	69	240/675	41042699	130			
943/515	9415220167	64	973/ 80	9738801070	162	240/675	98497821	130			
943/516	9305200119	64	973/ 84	9738800570	162	240/677	2993918	130			
943/517	9305200019	64	973/ 85	9738800470	162	240/677	41003248	130			
943/518	9305200120	64	973/ 88	9705253539	162						
943/519	9305200020	64	973/ 89	9705253439	162	Man					
943/520	9305200207	64	973/ 90	9738801170	162	M20/670	4711230	130			
943/525	9305200007	64	973/ 92	9705253539	-						
943/530	9305200419	64	973/ 93	9705253439	-	Volvo					
943/540	9305210097	-	973/ 94	9738801770	162	0FH/670	9520400	130			
943/541	9305210197	-	973/ 95	9738801670	162						
943/543	9305200195	-	973/140	9737500602	-						
943/544	9415207441	-	973/145	9738840105	-						
943/550	-	64	973/145	9738840185	-						
943/555	-	64	973/154	9738800105	-						
943/600	9438200261	-	973/155	9738800005	-						
943/601	9438200161	-	973/160	9738840223	169						
943/650	15406370	-	973/161	9738840123	169						
943/651	15406270	-	973/164	9737200446	165						
944/ 94	9418802870	132	973/165	9737200346	165						
944/ 95	9418802770	132	973/174	9737200246	165						
944/200	9416662001	136	973/175	9737200146	165						
944/200	9436663901	136	973/195	7601359	165						
944/201	9416661901	136	973/200	9736663001	164						
944/201	9436663801	136	973/201	9736662701	164						
944/210	9416663828	136	973/204	9736663601	164						
944/211	9416663728	136	973/205	9736663301	164						
944/212	9416663328	136	973/206	9736663201	163						
944/215	9416663428	136	973/207	9736663101	163						
944/216	9416663528	136	973/210	9736661428	163						
944/240	9416662201	136	973/211	9736661628	163						
944/240	9416662701	136	973/212	9736661528	163						
944/241	9416662101	136	973/500	9738110410	-						
944/241	9416662601	136									

MERCEDES

MERCEDES-BENZ SPRINTER

(2006) terza serie / third version / dritte Serie



1



210/ 75

210/ 90
s/fori fendinebbia - nero
without fog lamps - black
ohne Nebelscheinwerferausschnitte - Anthrazit



210/106



210/ 95
c/fori fendinebbia - nero
with fog lamps - black
mit Nebelscheinwerferausschnitte - Anthrazit



210/105



210/ 88





210/ 96

210/140



210/130



210/120





210/200 d/rh/rechts
210/201 s/lh/links

MERCEDES-BENZ SPRINTER (2006)
terza serie / third version / dritte Serie

6

210/ 90
s/fori fendinebbia - nero
without fog lamps - black
ohne Nebelscheinwerferausschnitte - Anthrazit

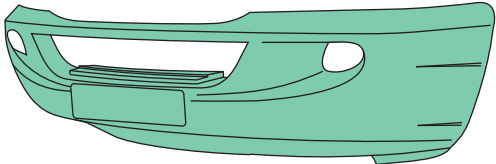
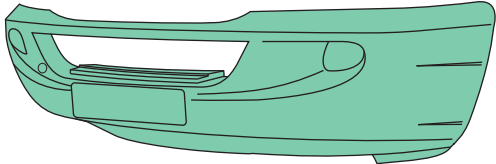

210/ 95
c/fori fendinebbia - nero
with fog lamps - black
mit Nebelscheinwerferausschnitte - Anthrazit

210/106

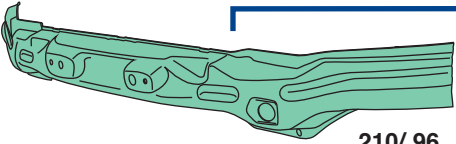
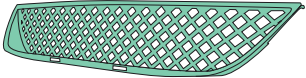

210/ 96

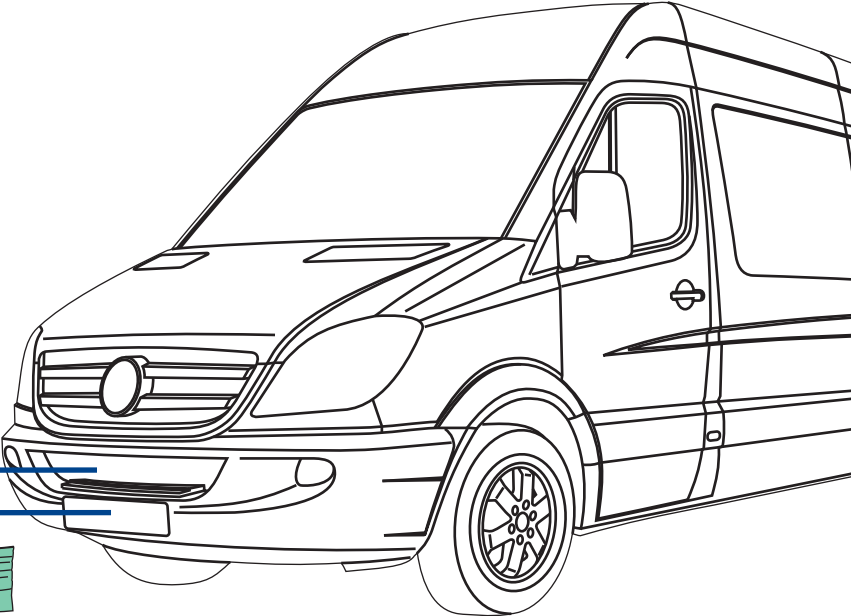

210/105

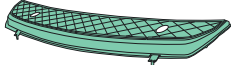

210/ 75



210/ 88

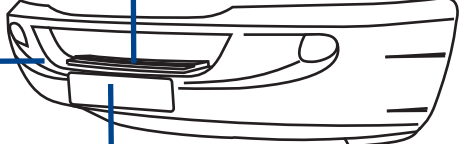
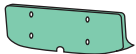

MERCEDES-BENZ SPRINTER (2006)
terza serie / third version / dritte Serie

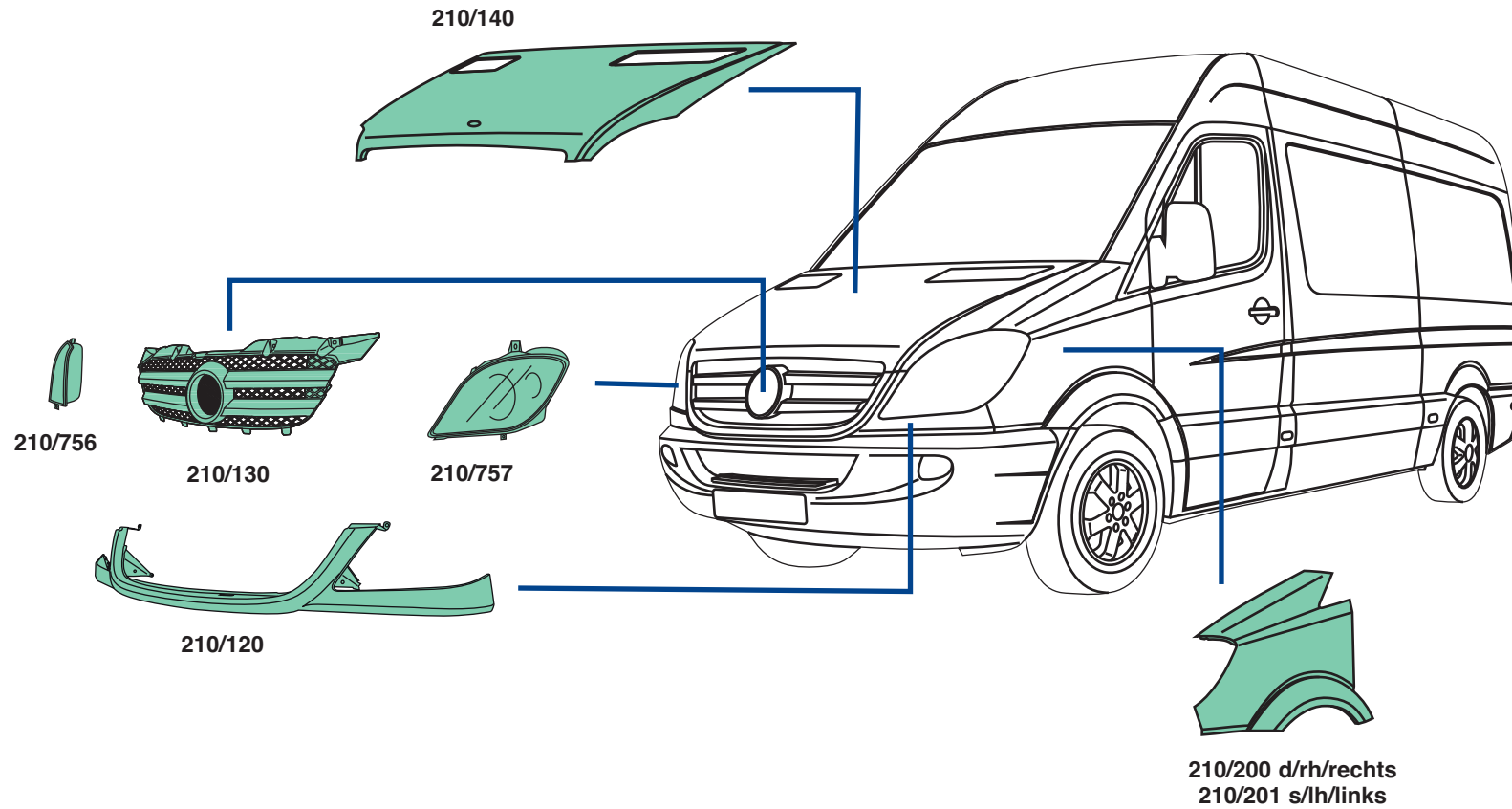

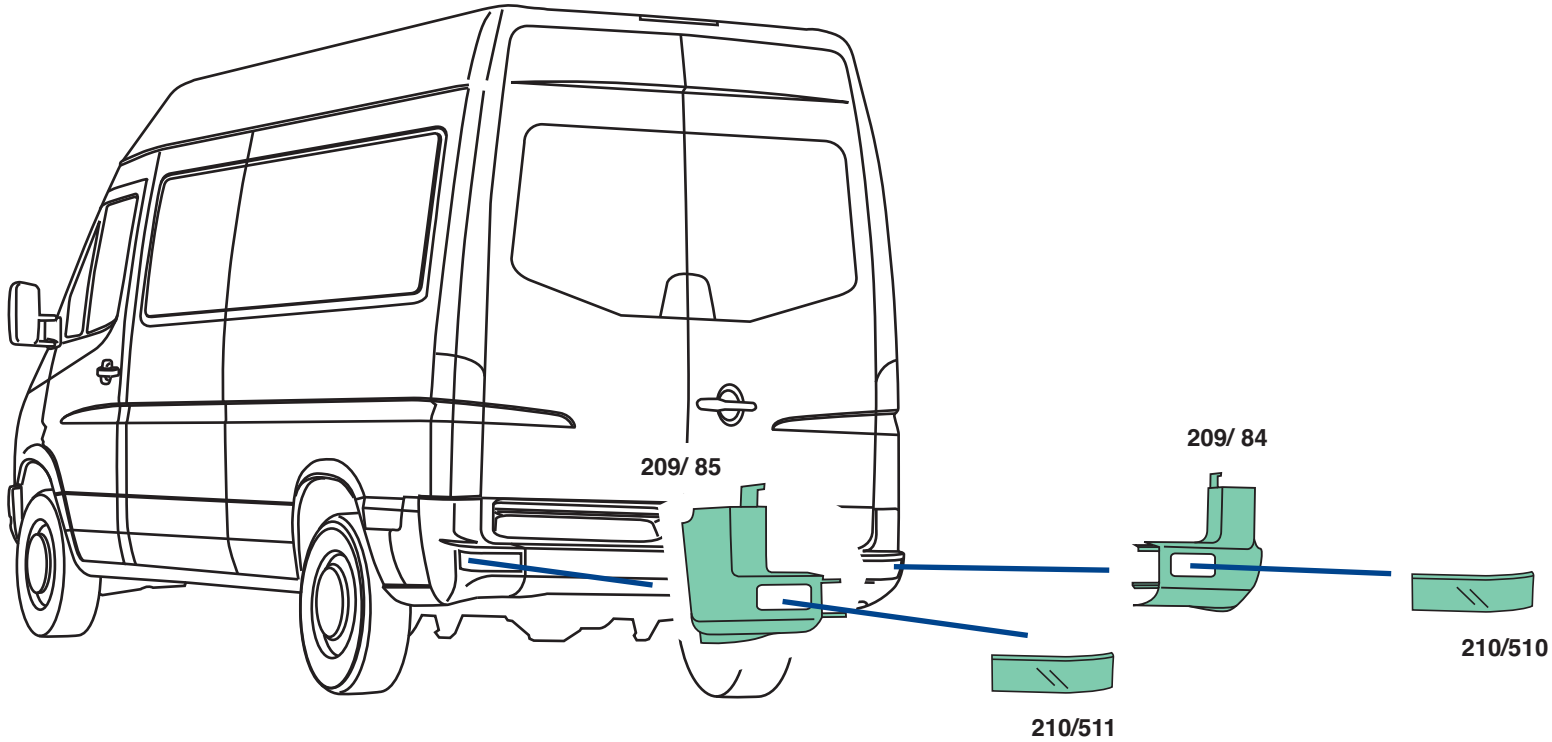



- ▲ IT Stampo in acciaio temprato per la produzione di paraurti
- UK Hardened steel mold for bumper production
- DE gehärtete Stahlform für Stossstangen Produktion

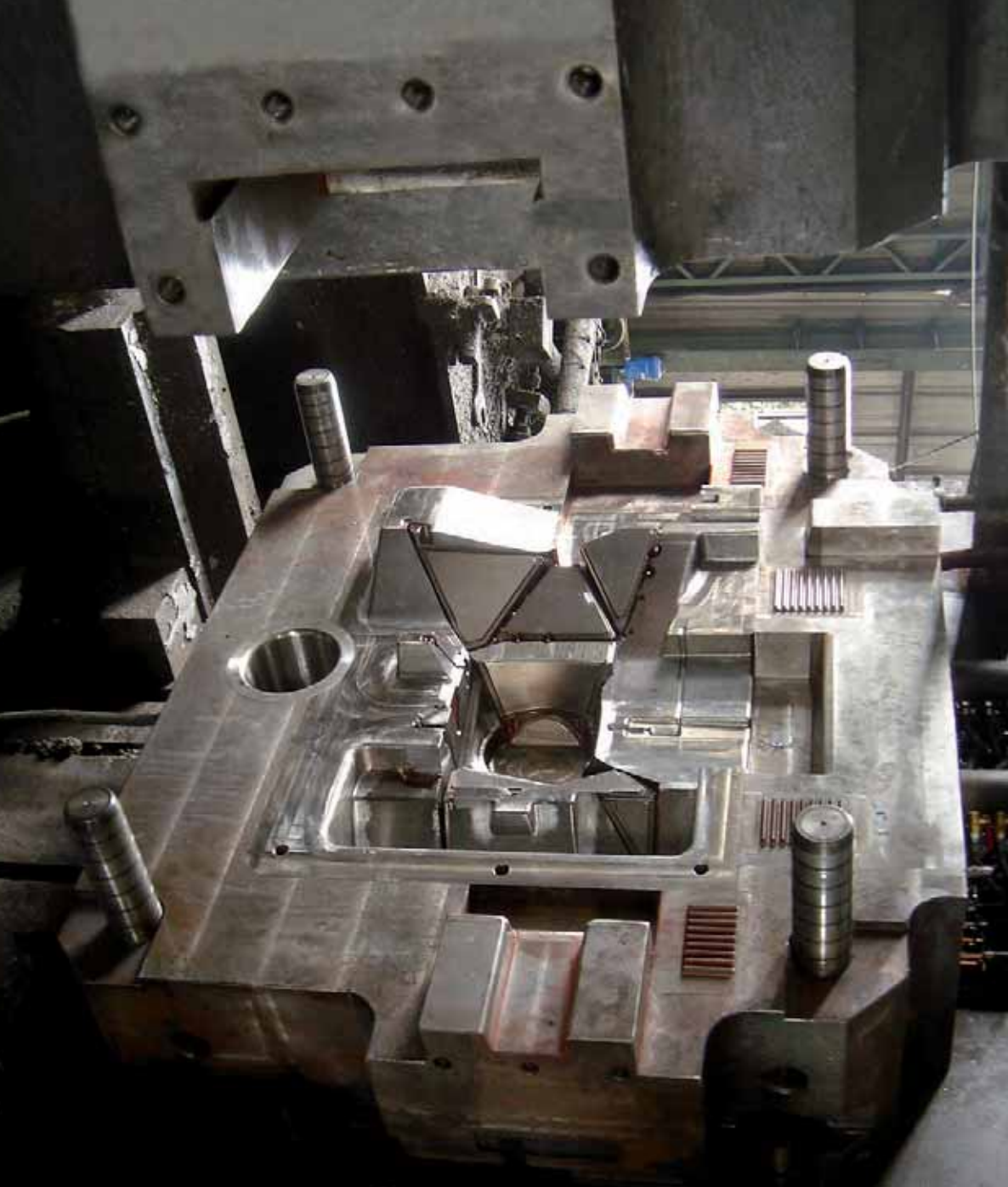

- ▲ IT Stampo per la pressofusione di un supporto porta faro
- UK High-pressure die-casting for head lamp frame
- DE offene Druckgußform für Lampenträger

MERCEDES

MERCEDES-BENZ SPRINTER

(2000-2005) seconda serie / second version / zweite Serie



11

209/135
guida destra / rh drive
Rechtslenker

209/150
guida sinistra / lh drive
Linkslenker

209/145

209/ 95
c/foro tergifaro
with headlight wipers
mit Scheinwerferreinigungsanlage

209/ 90
s/foro tergifaro
without headlight wipers
ohne Scheinwerferreinigungsanlage





209/ 96



209/200 d/rh/rechts
209/201 s/lh/links

209/ 90
s/foro tergifaro
without headlight wipers
ohne Scheinwerferreinigungsanlage

209/105
s/foro tergifaro
without headlight wipers
ohne Scheinwerferreinigungsanlage
hellgrau-grundiert

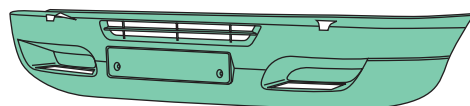
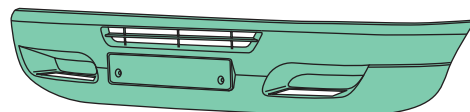
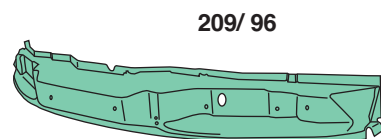

209/ 95
c/foro tergifaro
with headlight wipers
mit Scheinwerferreinigungsanlage

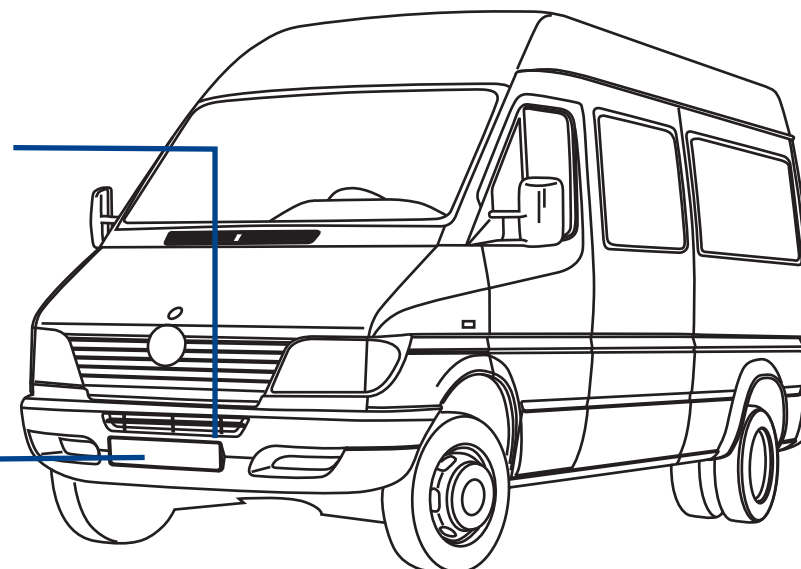
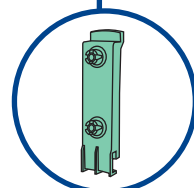

MERCEDES-BENZ SPRINTER (2000-2005)
seconda serie / second version / zweite Serie

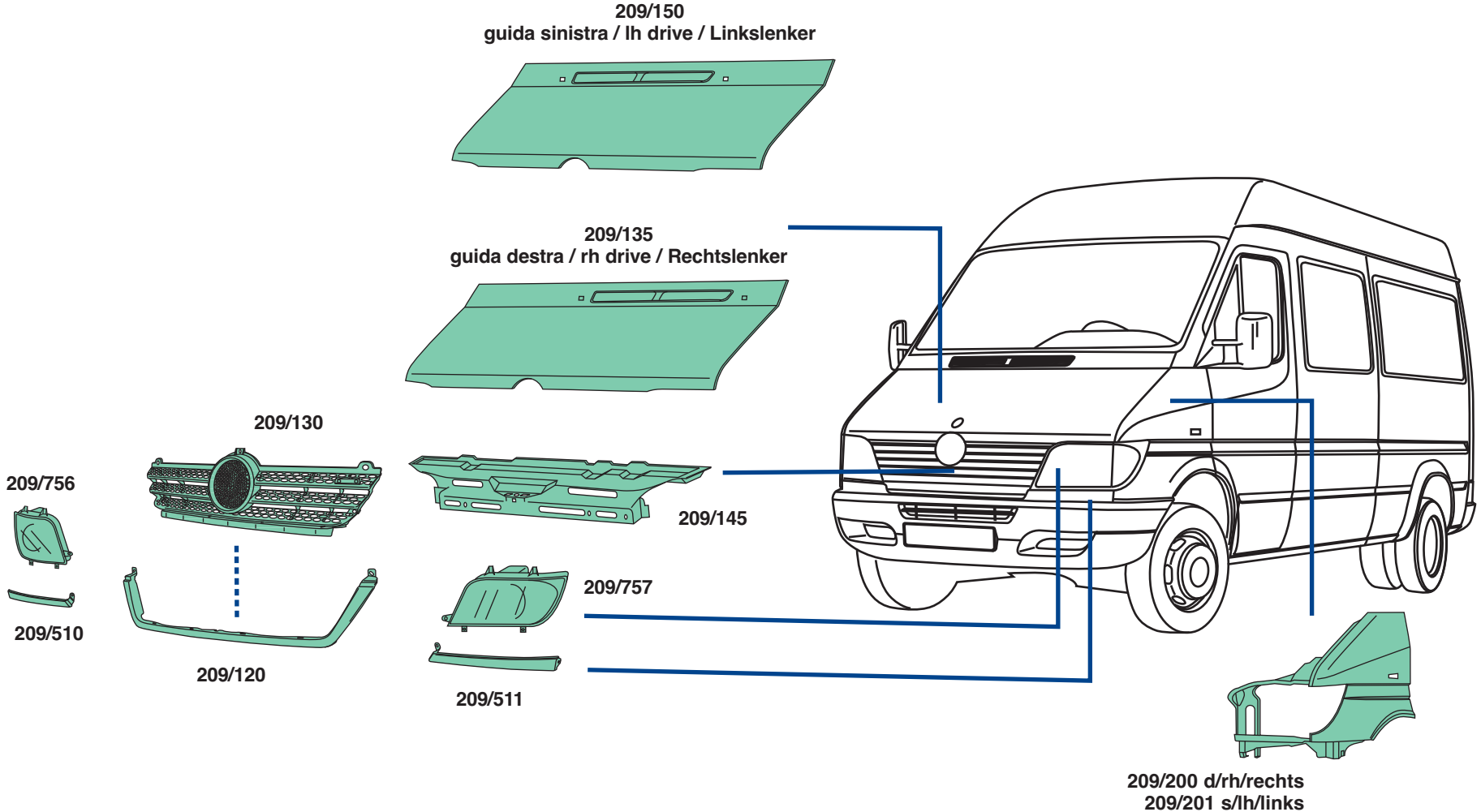

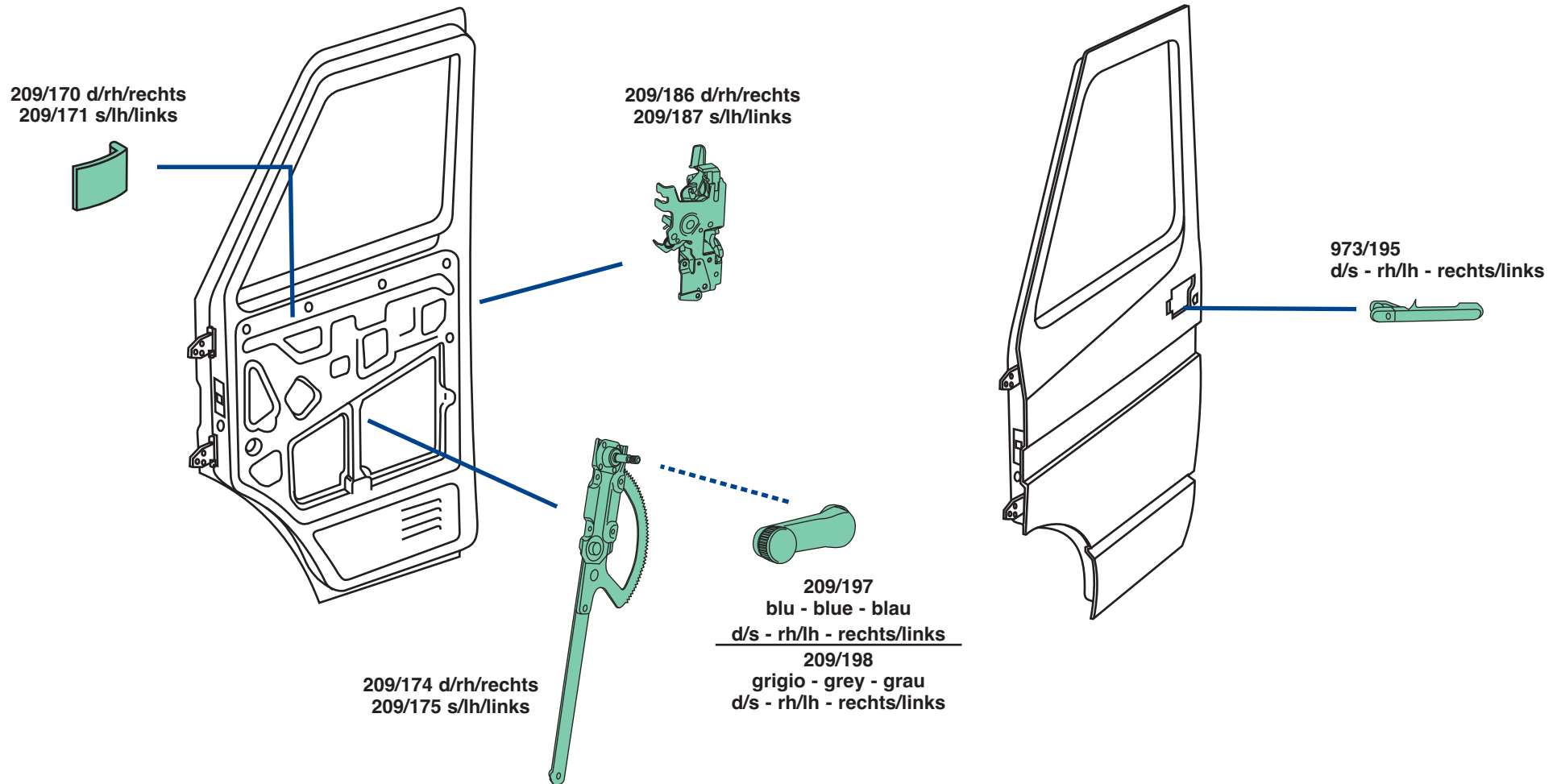

MERCEDES·BENZ SPRINTER (2000-2005)
seconda serie / second version / zweite Serie

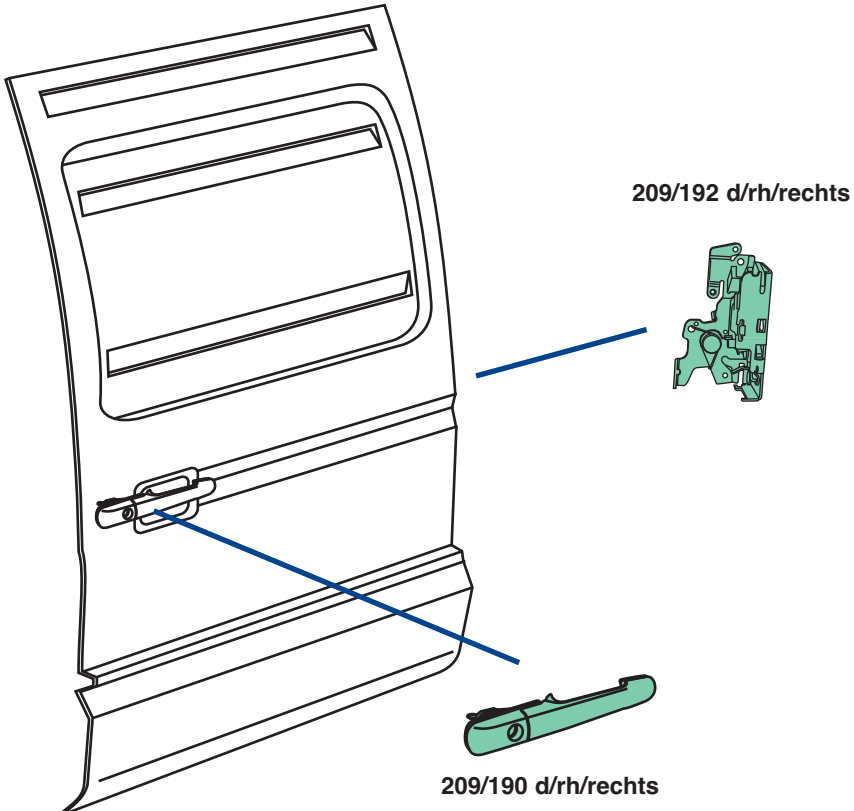
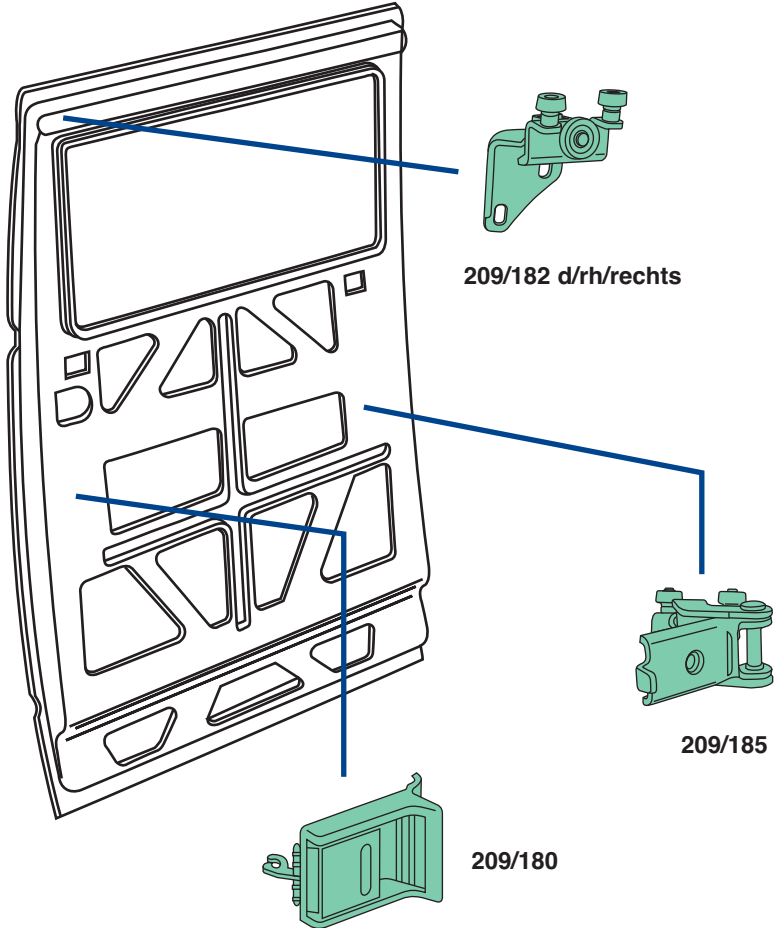

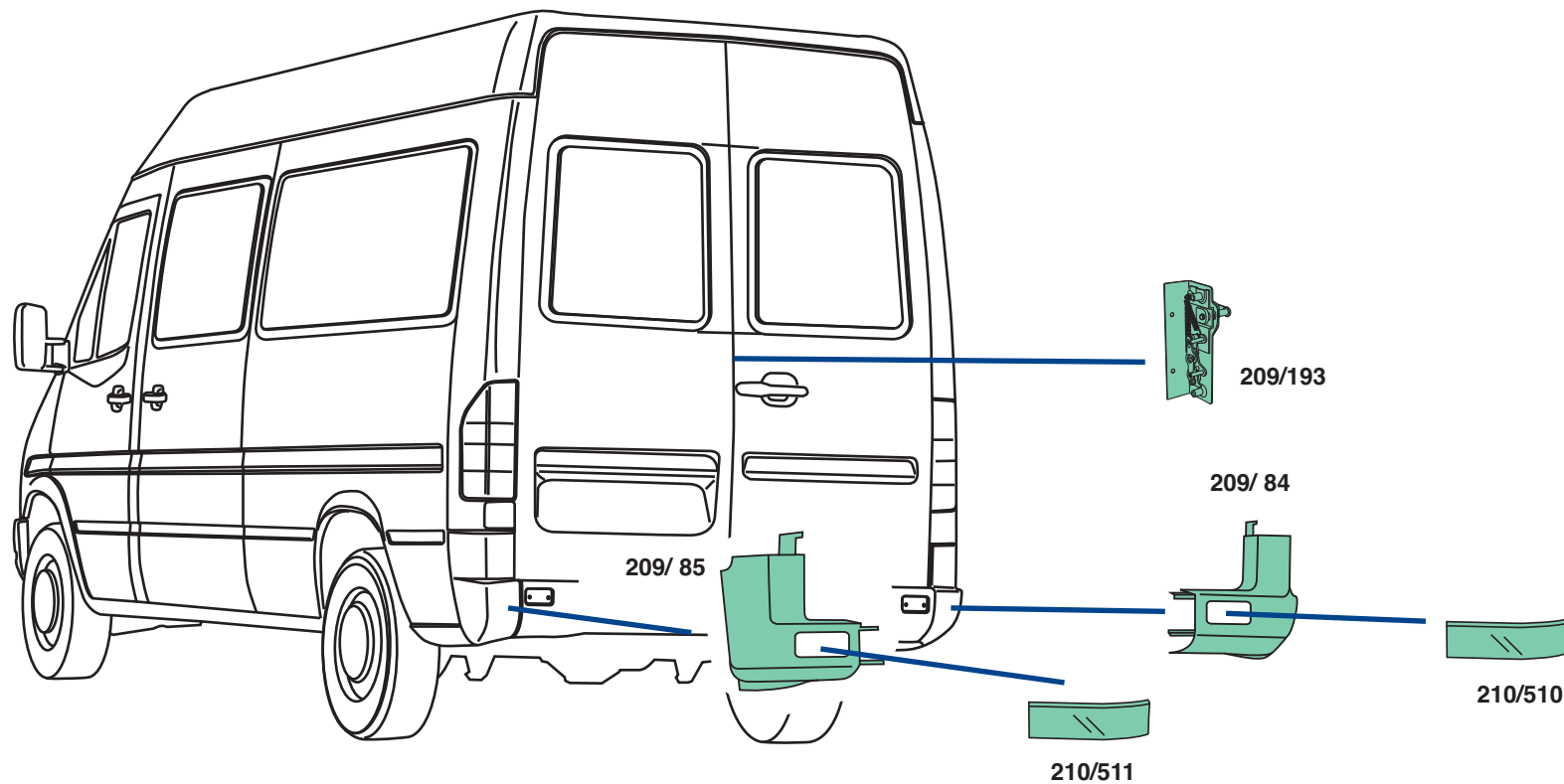

MERCEDES-BENZ SPRINTER (2000-2005)
seconda serie / second version / zweite Serie

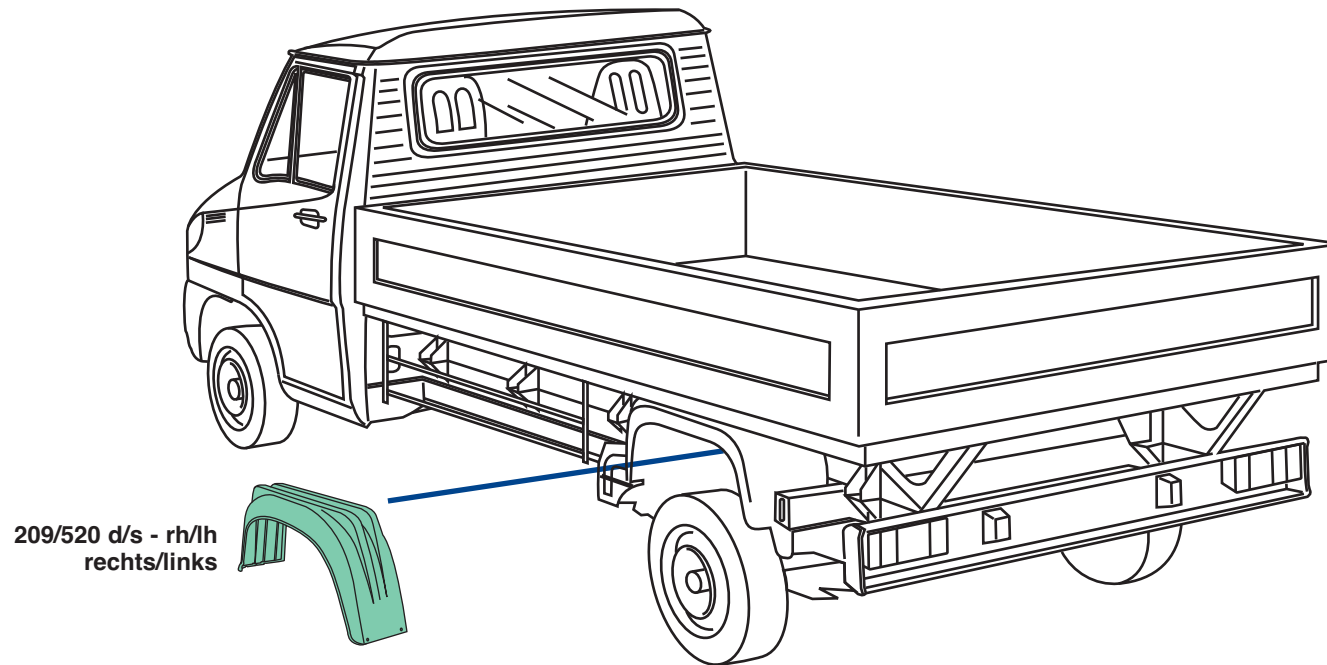



- ▲ IT Stampo in acciaio temprato per la produzione di un deviatore aria
- UK Hardened steel mold for production for air buffle
- DE gehärtete Stahlform für Luftleitblech

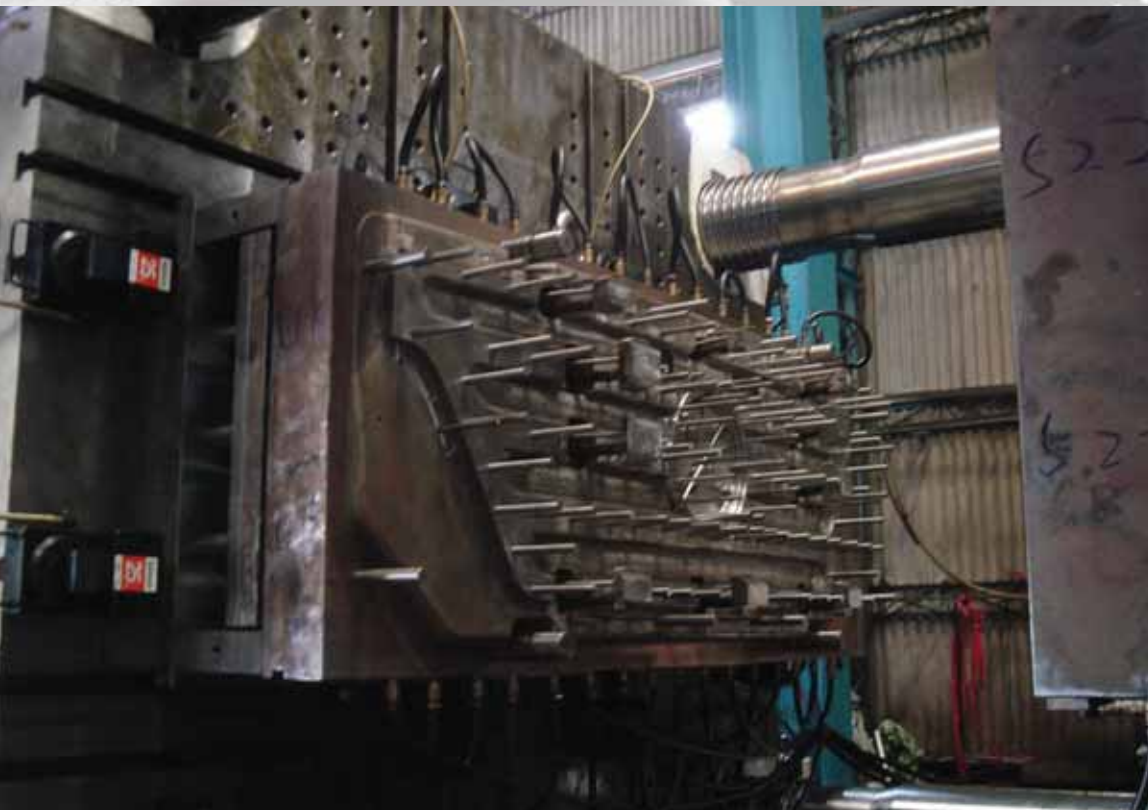

- ▲ IT Stampo in acciaio temprato per la produzione di una griglia in ABS
- UK Hardened steel mold for production fo ABS front grille
- DE gehärtete Stahlform für ABS Frontgrill Produkte



▲ IT Stampo in acciaio temprato per la produzione del paraurti in SMC

UK Hardened steel mold for bumper production

DE offene gehärtete Stahlform für SMC Stossstangen Produktion

MERCEDES

MERCEDES-BENZ SPRINTER
(1995-1999) prima serie / first version / erste Serie



23



208/140



208/130



208/ 90



208/200 d/rh/rechts
208/201 s/lh/links



208/ 85 s/lh/links



208/ 81



208/ 84 d/rh/rechts

MERCEDES-BENZ SPRINTER (1995-1999)
prima serie / first version / erste Serie

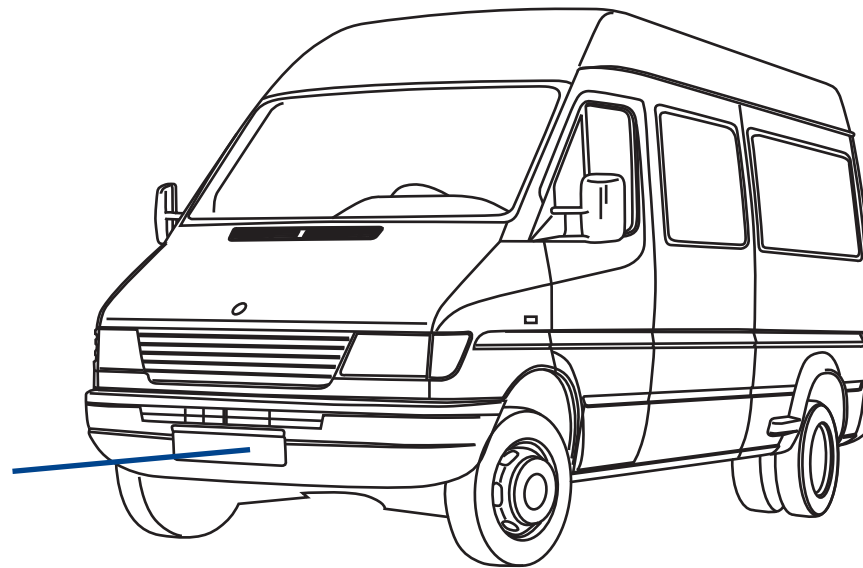
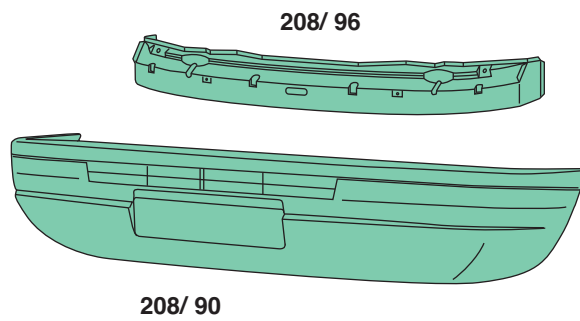

MERCEDES·BENZ SPRINTER (1995-1999)
prima serie / first version / erste Serie

28

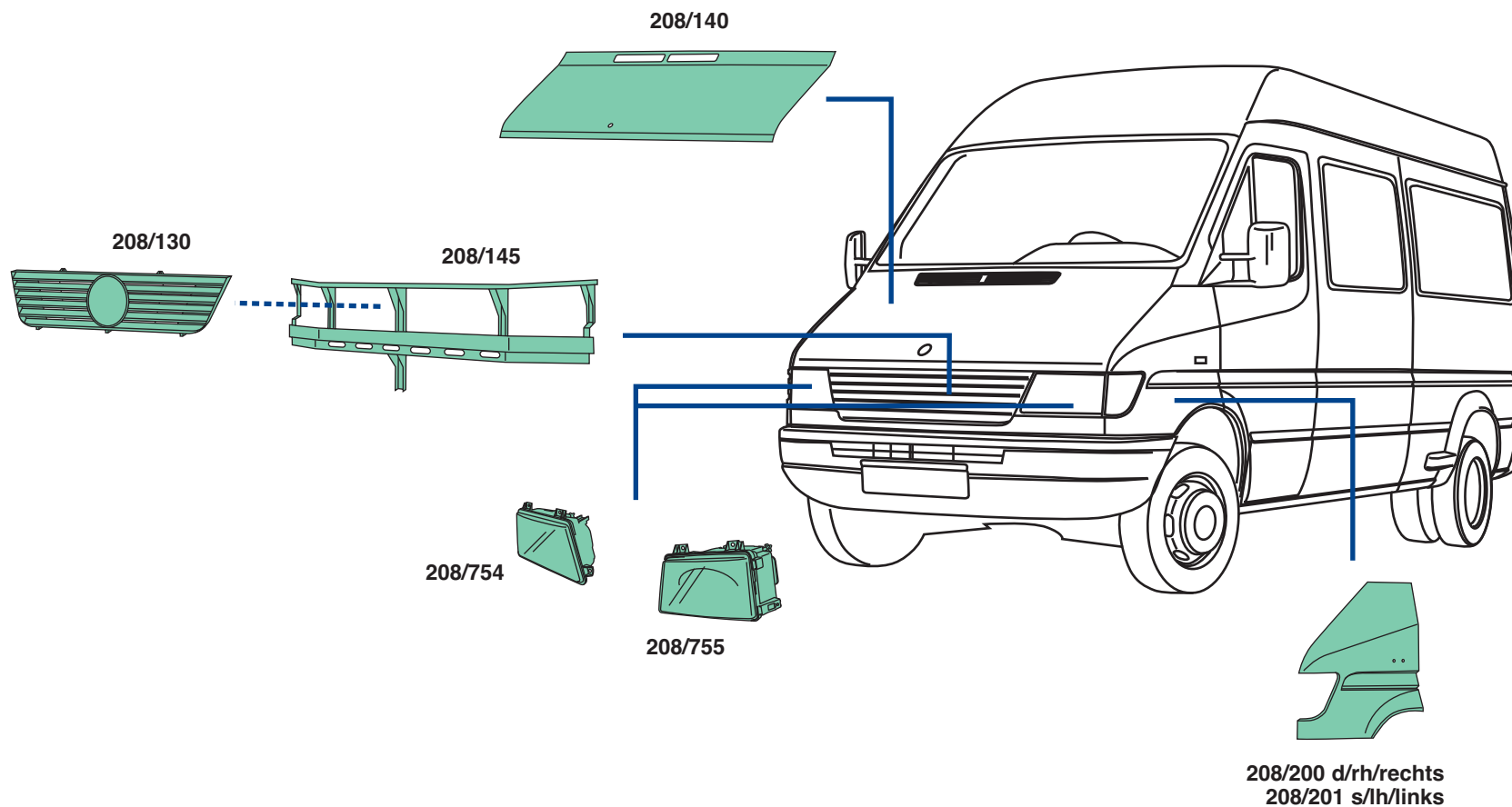

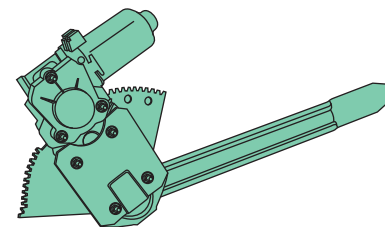
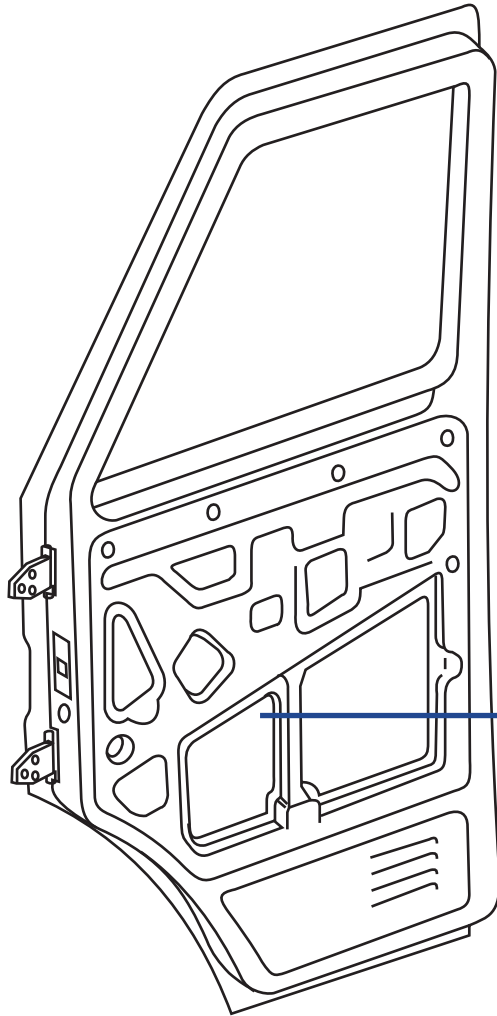

208/166 d/rh/rechts
208/167 s/lh/links
elettrico
electric
elektrisch

MERCEDES-BENZ SPRINTER (1995-1999)
prima serie / first version / erste Serie

30

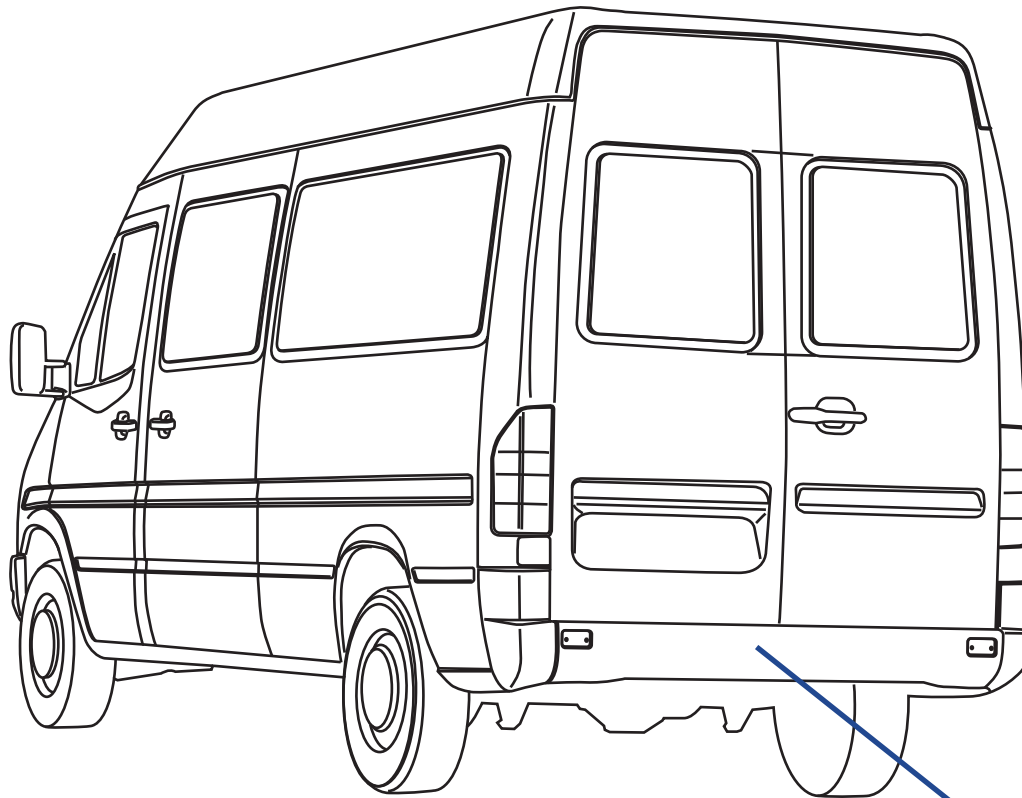

208/ 85

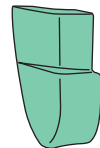

208/ 81

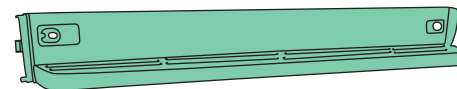

208/ 84



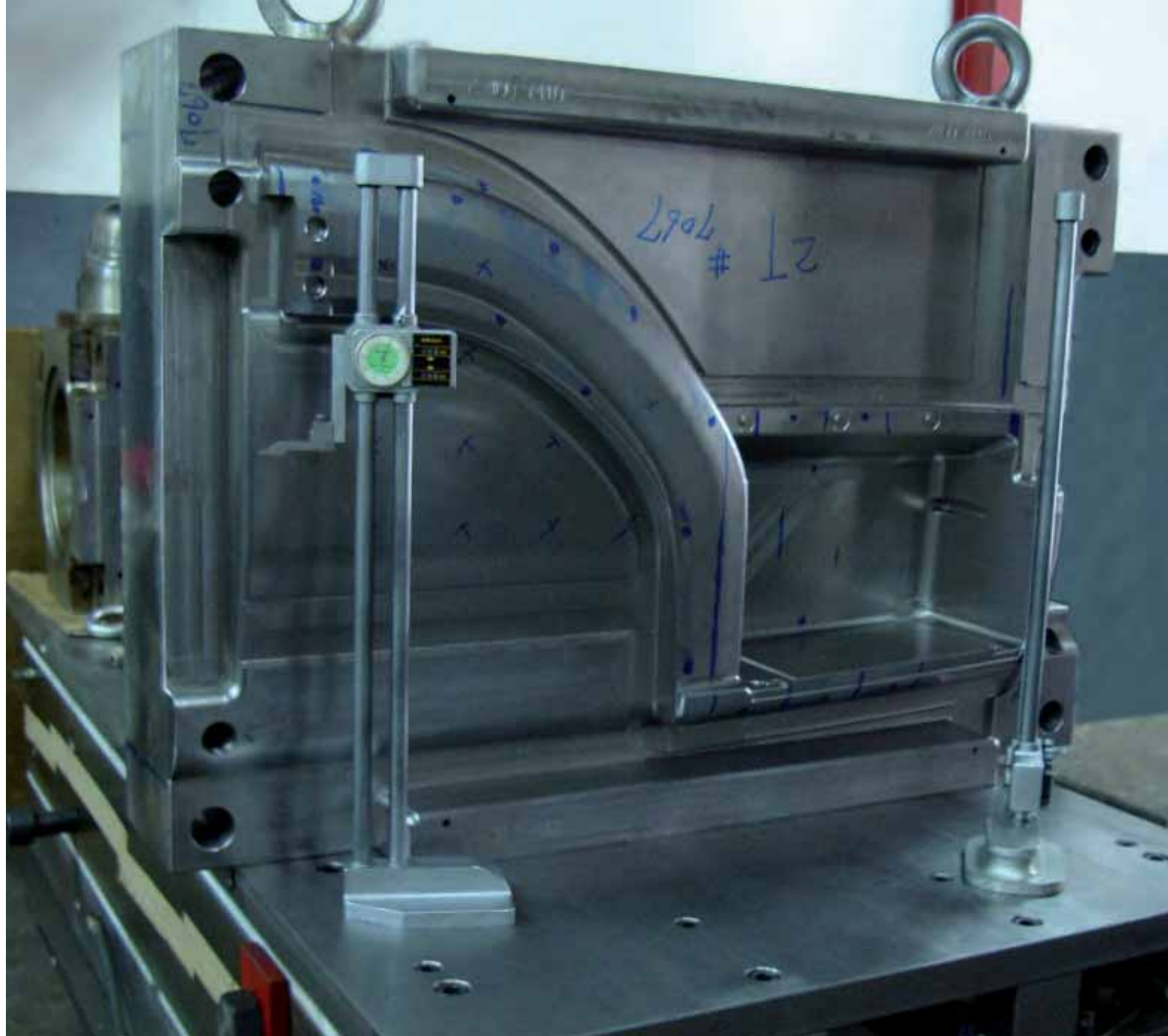

- ▲ IT Stampo in acciaio per la realizzazione di parafanghi in SMC
- UK hardened steel mold for production of mudguard in SMC
- DE offene gehärtete Stahlform für SMC Kotflügel Produktion



- ▲ IT Stampo in acciaio temprato per la realizzazione di un cantonale in SMC
- UK Hardened steel mold for corner part in SMC production
- DE offene gehärtete Stahlform für SMC Stossstangen Produktion

MERCEDES

MERCEDES-BENZ MB207

33



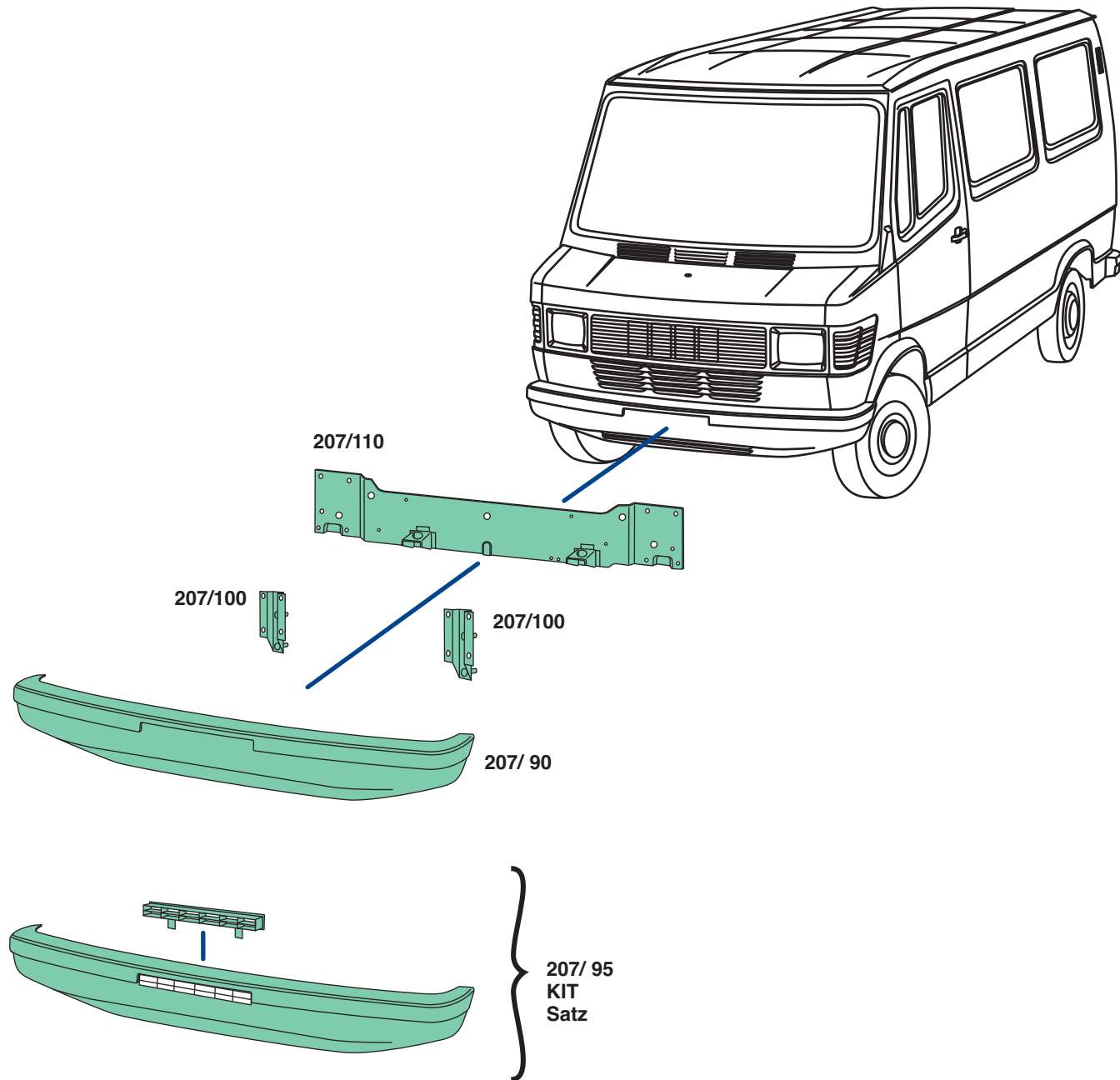

MERCEDES-BENZ MB207
L207D-L208D-L210D-L307D-L308D-L309D-L310D-L407D-L408D-L409D-L410D

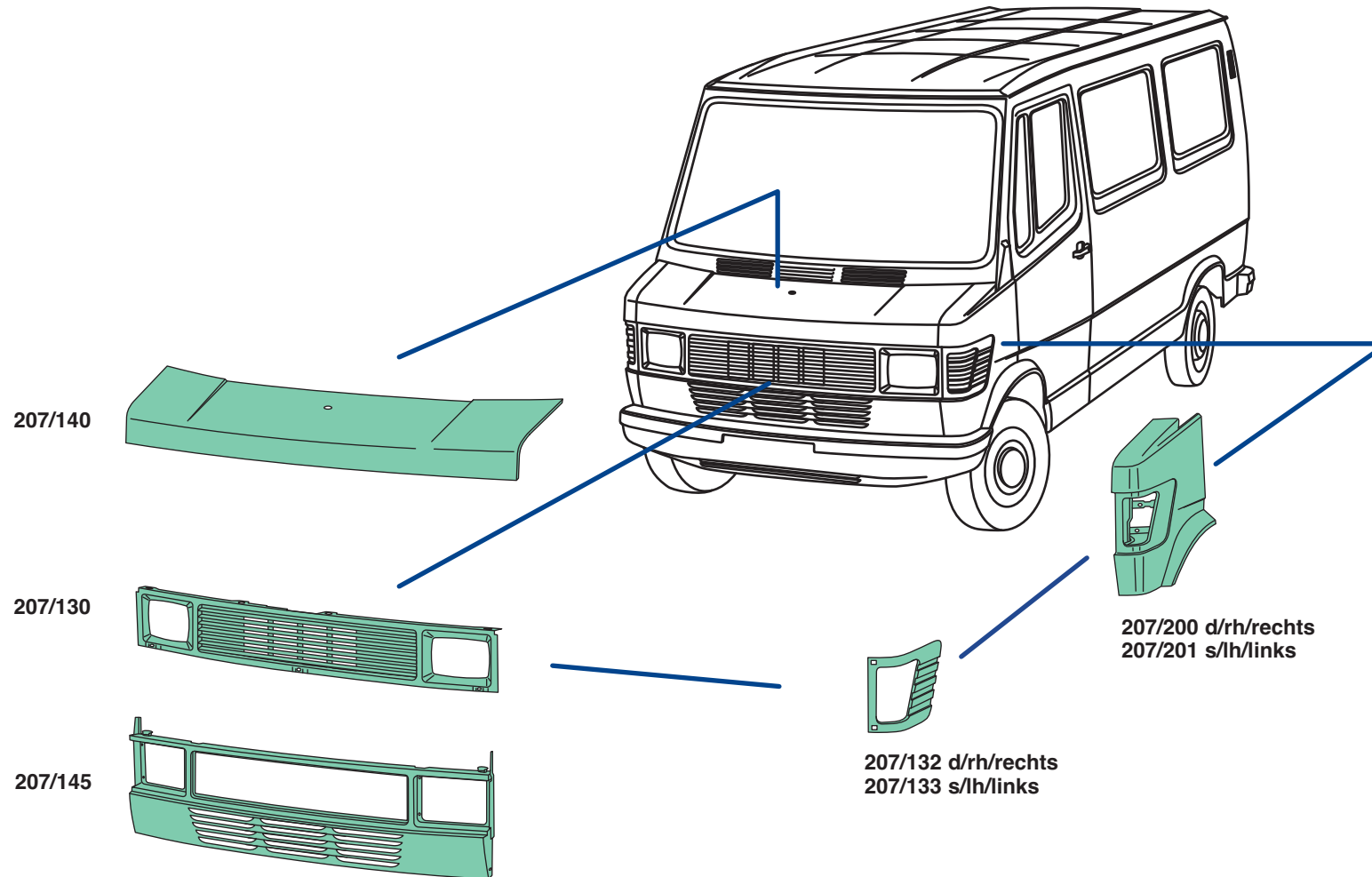

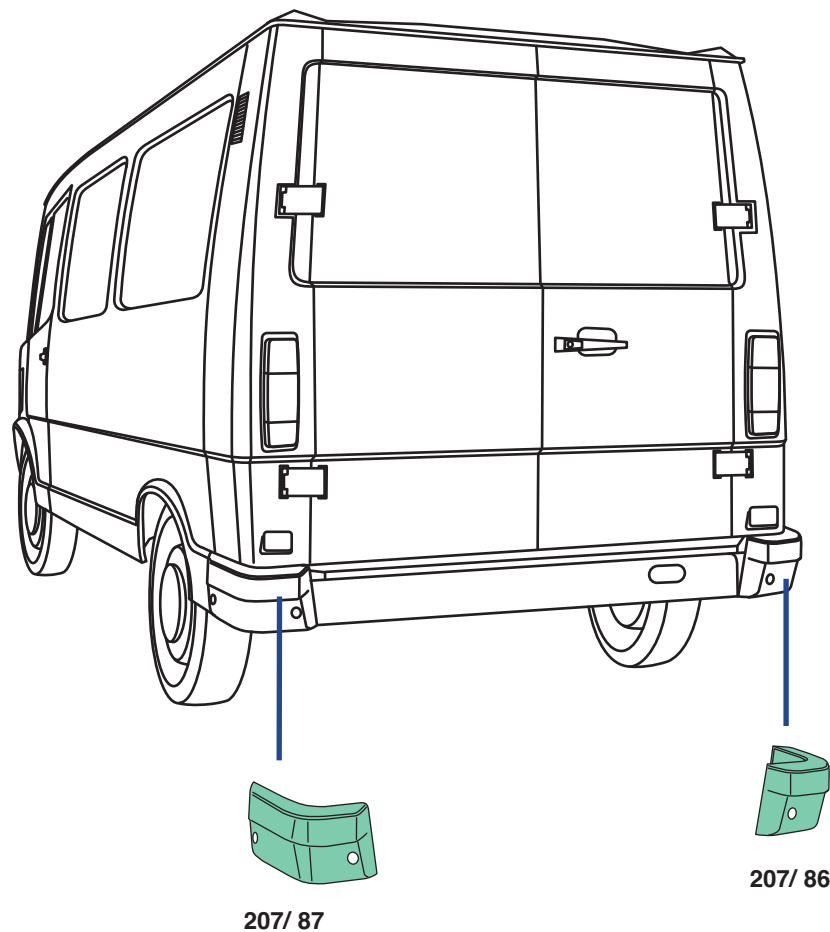

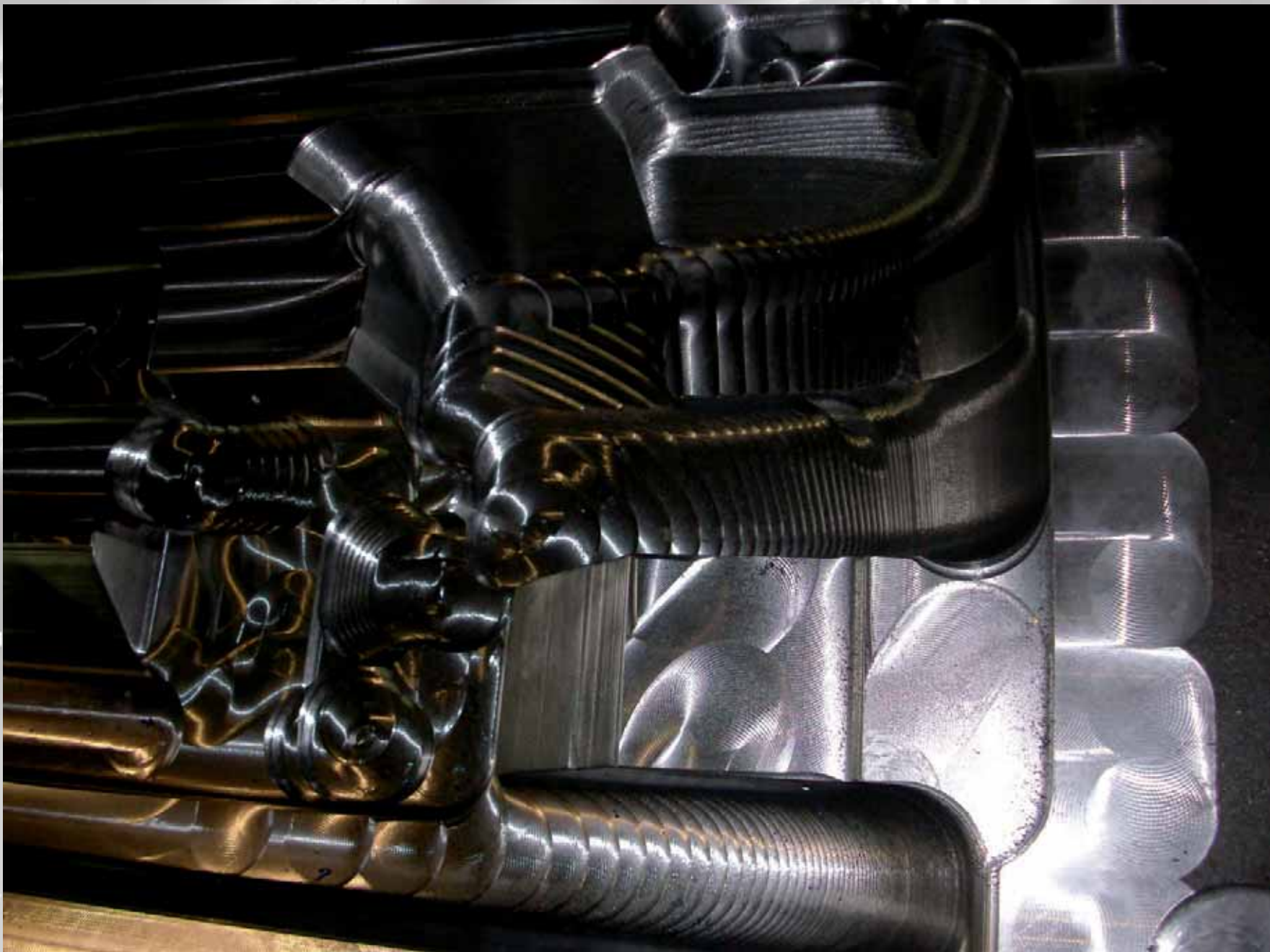

- ▲ IT Una delle fasi di lavorazione dello stampo per la realizzazione di un paraurti
- UK One of the manufacturing steps of a mold for bumper production
- DE Aufbau und Herstellung einer Stahlform für die Stossstangenproduktion.

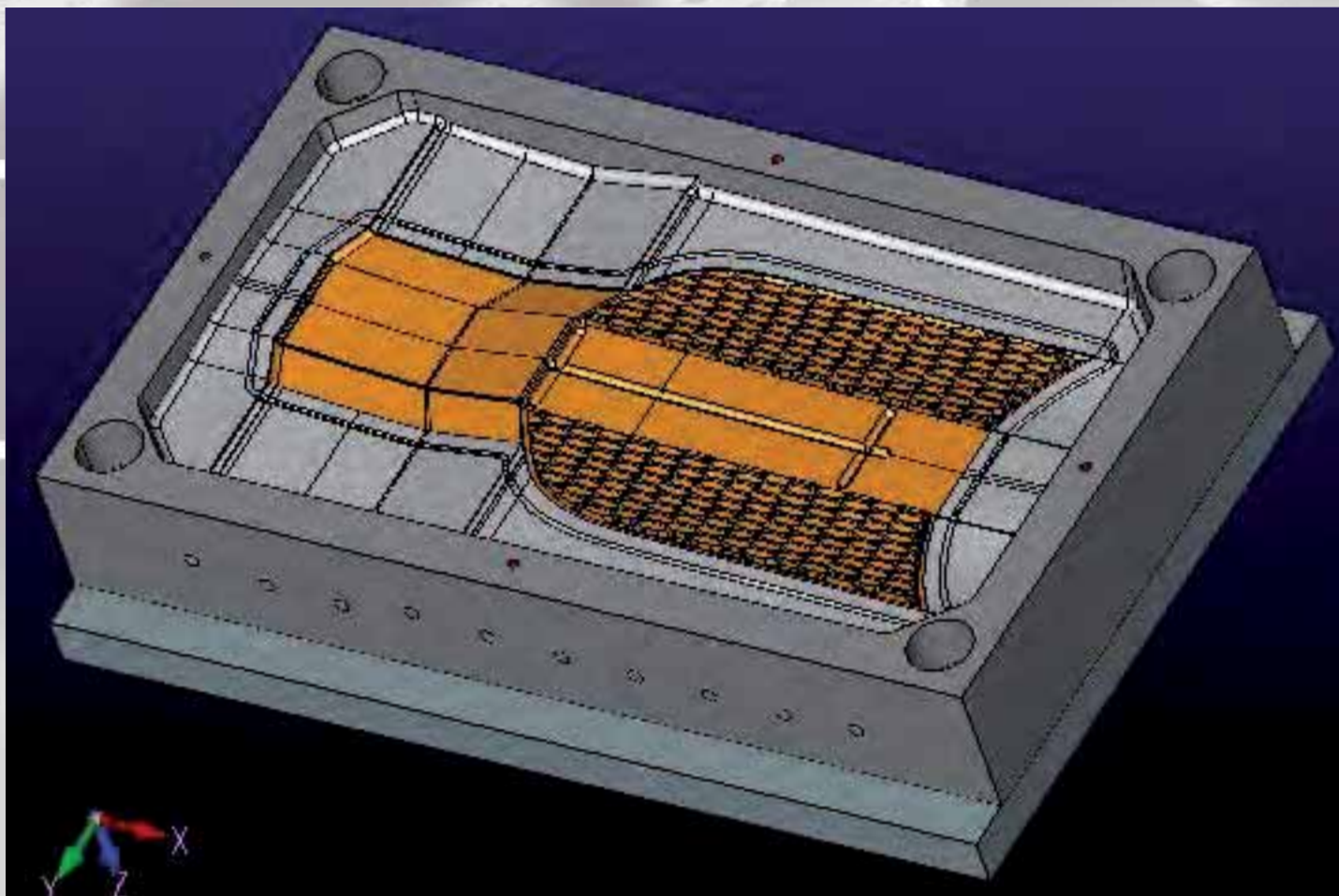

- ▲ IT Progetto in 3D dello stampo ad iniezione per la produzione di griglie
- UK 3-D Project for the mould to be used for the production of grille
- DE 3D-Projekt der Stahlform für die Herstellung von Grill

MERCEDES

MERCEDES-BENZ VITO

39



108/164 d/rh/rechts
108/165 s/lh/links
senza pannello
without panel
ohne Blende

108/200 d/rh/rechts
108/201 s/lh/links



108/140



108/130



108/ 94 d/rh/rechts
108/ 95 s/lh/links



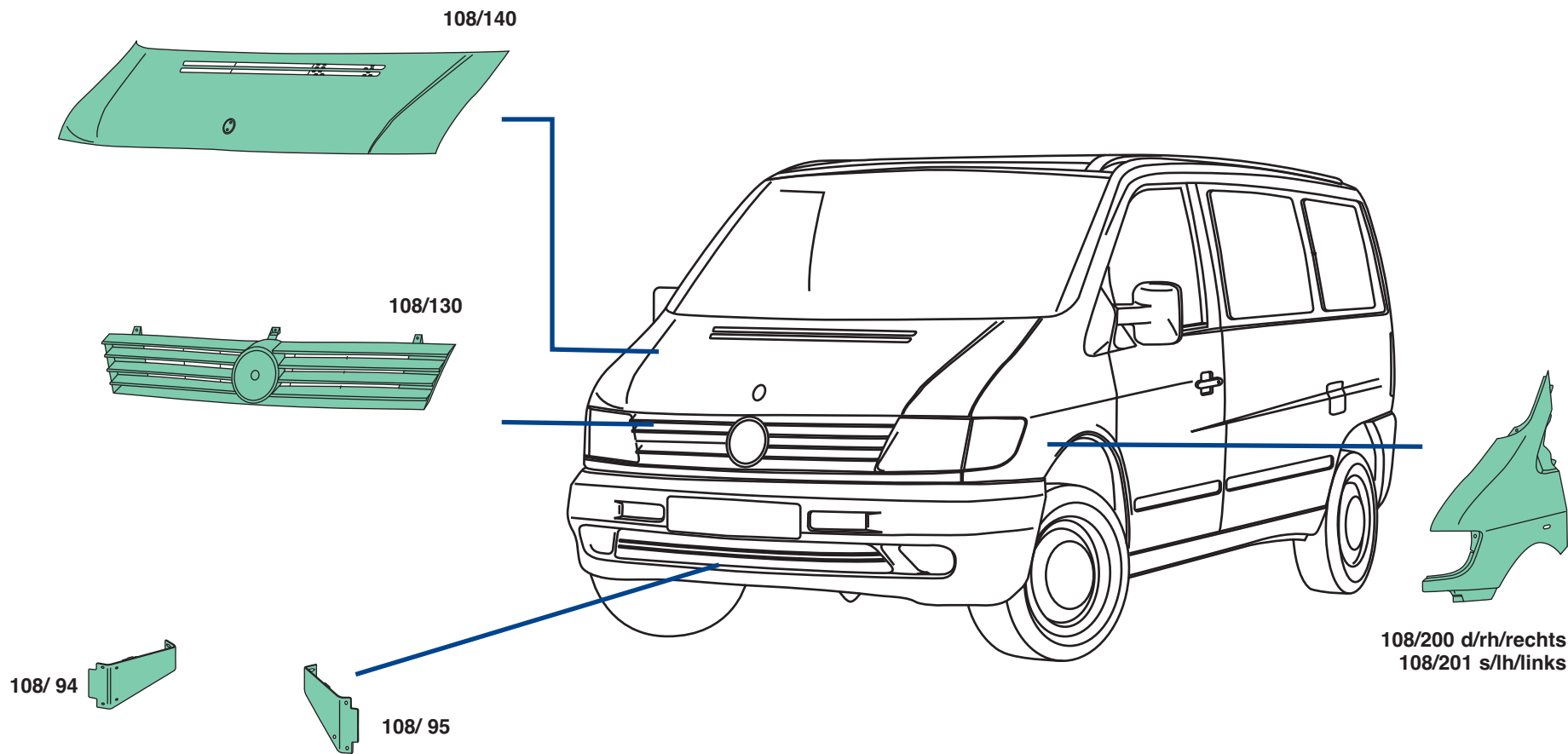

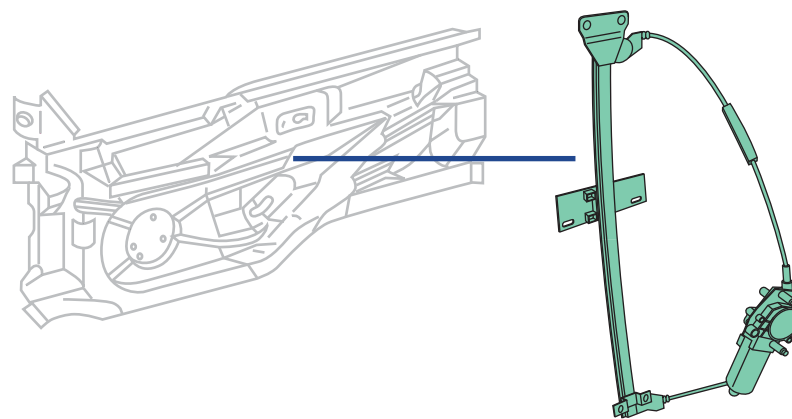
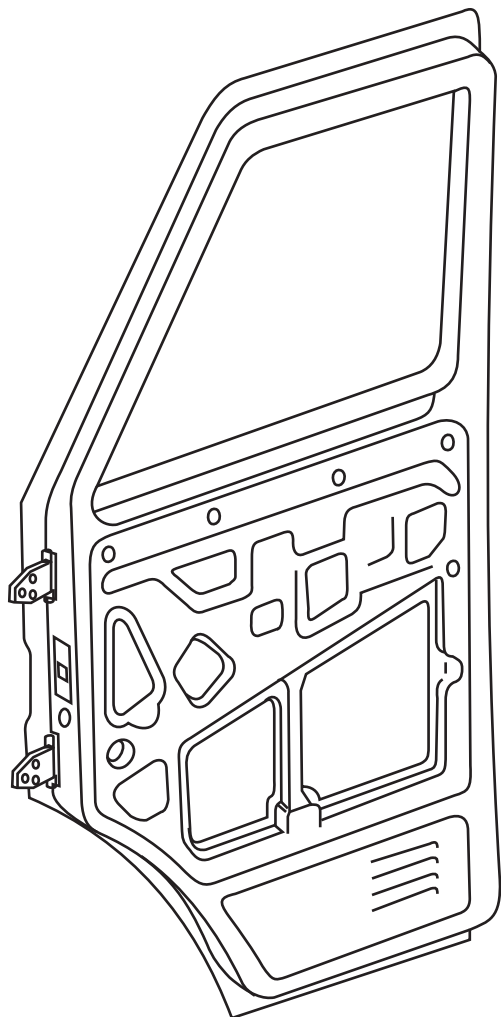

108/164 d/rh/rechts
108/165 s/lh/links
senza pannello
without panel
ohne Blende

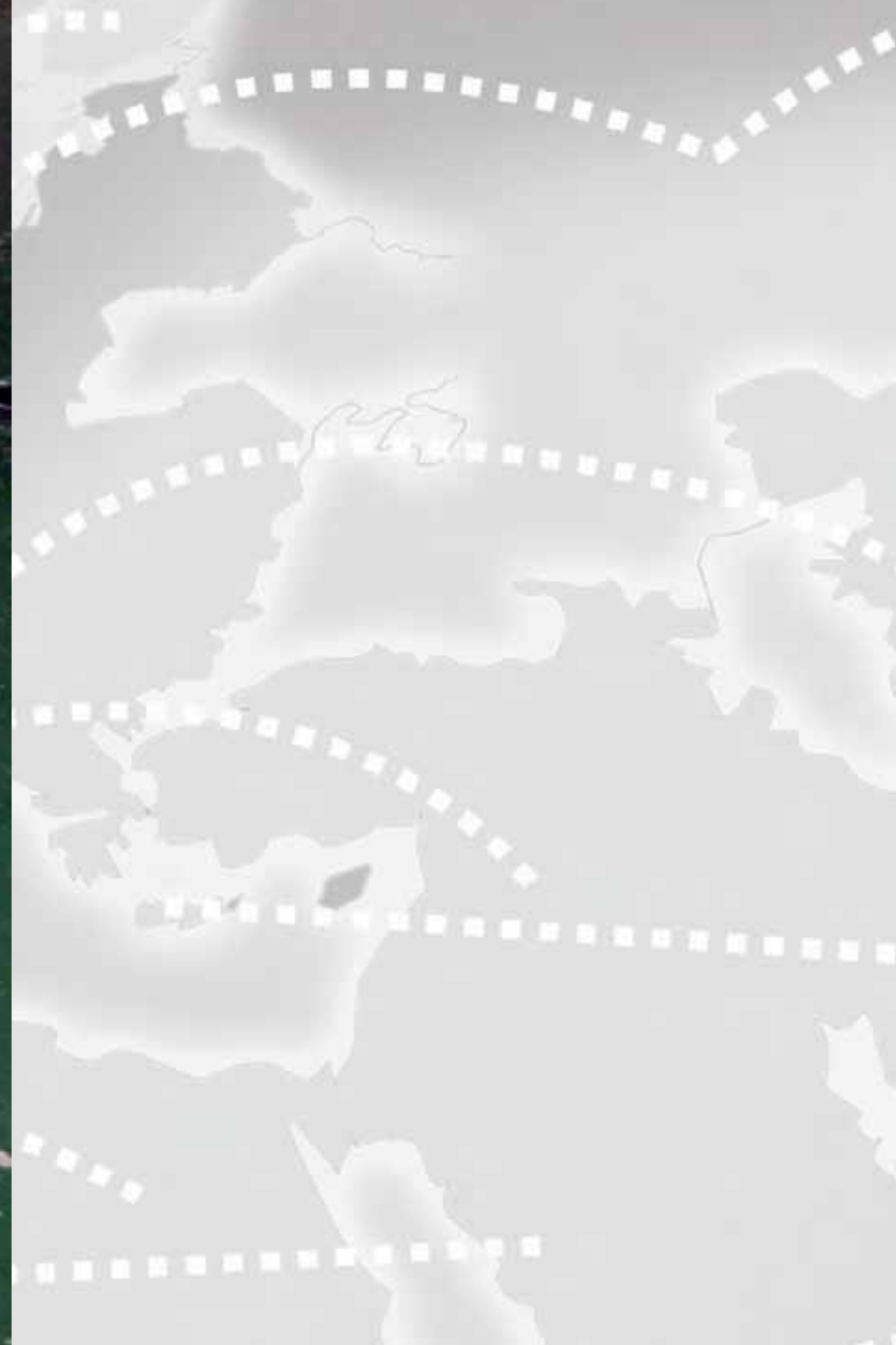

- ▲ IT Una delle fasi di lavorazione dello stampo per la realizzazione di un paraurti
- UK One of the manufacturing steps of a mold for bumper production
- DE Aufbau und Herstellung einer Stahlform für die Stosstangenproduktion.

MERCEDES

MERCEDES · BENZ MB100

45



MERCEDES·BENZ MB100
MB100D-MB100-120-140-180

46

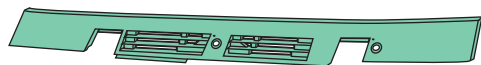

100/108

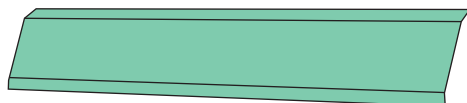

100/110

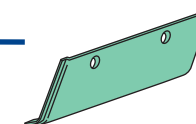
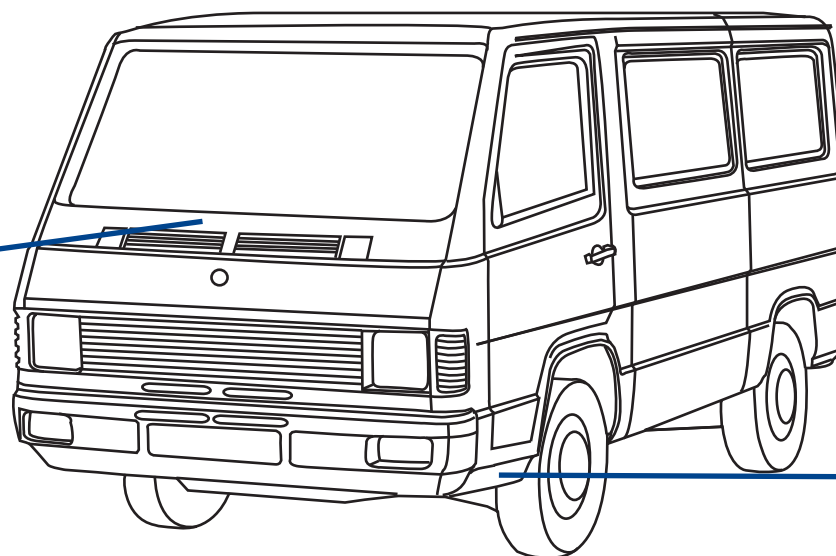

100/236 d/rh/rechts
100/237 s/lh/links



- ▲ IT Stampo in acciaio temprato per la realizzazione di una pedana parafango
- UK Hardened steel mold for production of foot board mudguard in SMC
- DE offene gehärtete Stahlform für die Produktion von Einstiegen in SMC

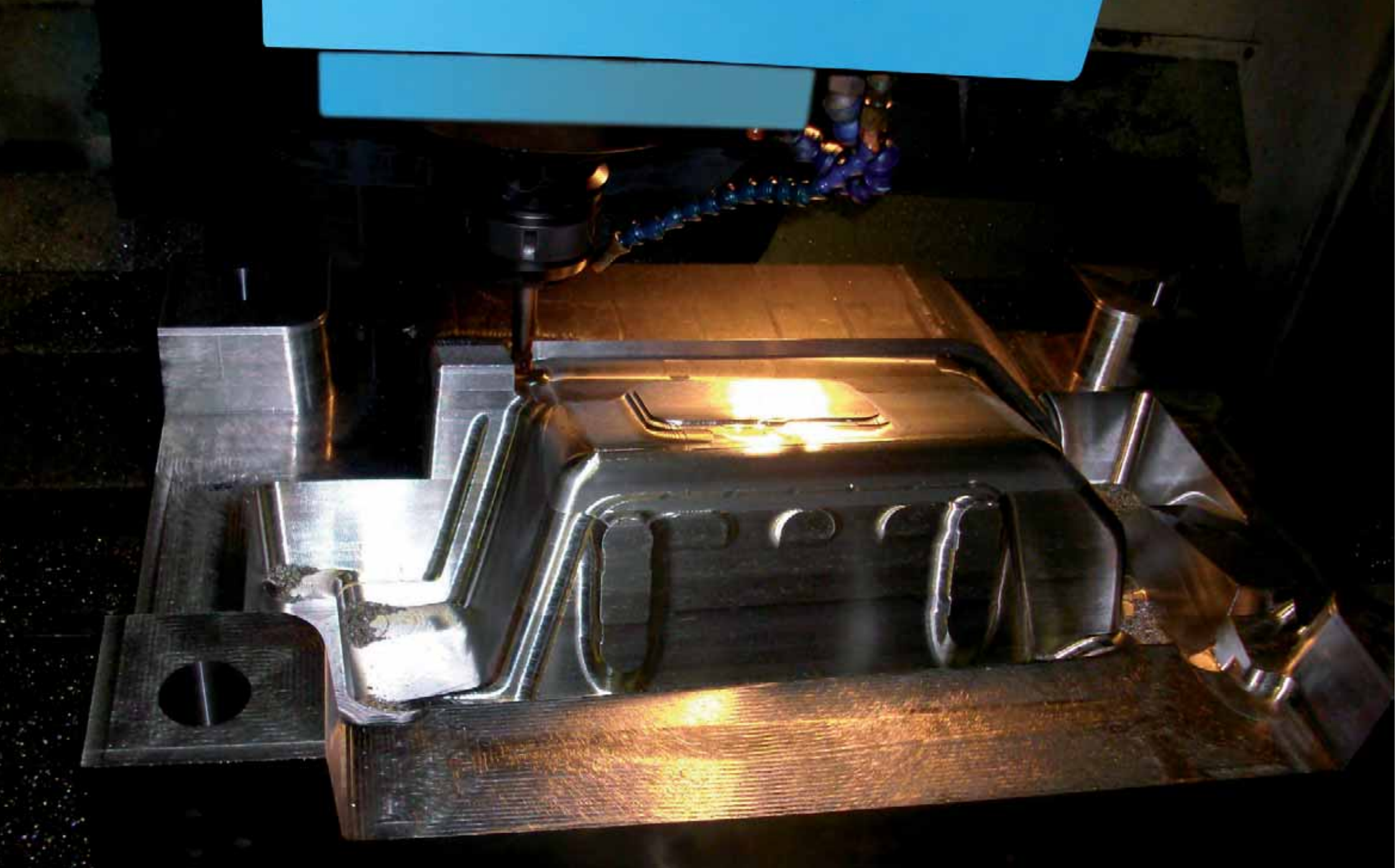

- ▲ IT Stampo maschio in acciaio temprato per la realizzazione di una pedana in SMC
- UK hardened steel mold (snapping tool) for footboard in SMC production
- DE geöffnete Stahlform für die SMC Produktion von Einstiegen

MERCEDES

MERCEDES-BENZ ACTROS 3

49



943/ 52
 c/foro tergifaro - s/foro fendinebbia
 c/presa aria - c/bordo alto -plastica-
 with headlight wipers - with fog lamp hole
 with air intake with high edge -plastic-
 mit Ausschnitt für
 Scheinwerferreinigungsanlage
 ohne Nebelscheinwerferausschnitt

943/ 53
 c/foro tergifaro - s/foro fendinebbia
 c/presa aria - c/bordo alto -plastica-
 with headlight wipers - with fog lamp hole
 with air intake with high edge -plastic-
 mit Ausschnitt für
 Scheinwerferreinigungsanlage
 ohne Nebelscheinwerferausschnitt

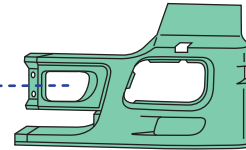
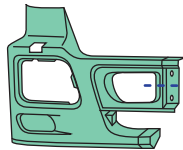

943/ 72

943/ 73

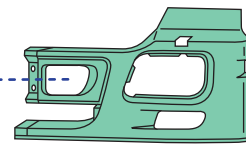
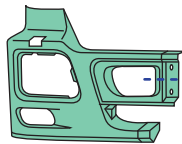

943/ 72

943/ 73

943/ 50
 c/foro tergifaro - c/foro fendinebbia
 c/presa aria - c/bordo basso -plastica-
 with headlight wipers - with fog lamp hole
 with air intake with low edge -plastic-
 mit Ausschnitt für
 Scheinwerferreinigungsanlage
 mit Nebelscheinwerferausschnitt

943/ 51
 c/foro tergifaro - c/foro fendinebbia
 c/presa aria - c/bordo basso -plastica-
 with headlight wipers - with fog lamp hole
 with air intake with low edge -plastic-
 mit Ausschnitt für
 Scheinwerferreinigungsanlage
 mit Nebelscheinwerferausschnitt



943/ 98 d/rh/rechts
 943/ 99 s/lh/links

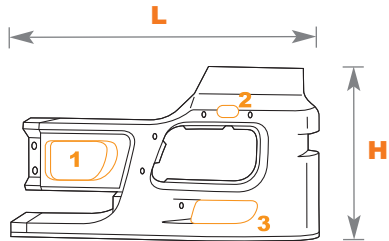

Legenda:
Key:
Legende:

1. Foro presa aria
Air intake
Luftausschnitt

2. Foro tergi faro
Headlight wipers
Scheinwerferreinigungsanlage

3. Foro faro fendinebbia
Fog lamp hole
Nebelscheinwerferausschnitt



Codice Covind	Covind References	Covind Art. Nr.	Codice Originale	O.E. References	Vergleichs-Nr.	1	2	3	L	H	Peso	Weight	Gewicht	Colore	Color	Farbe	Materiale	Material	Material
943/ 50	d/rh/rechts		9438807772			✓	✓	✓	1005 mm	565 mm	5,270	Kg		grigio/grey/grau			SMC		
943/ 51	s/lh/links		9438807672			✓	✓	✓	1005 mm	565 mm	5,270	Kg		grigio/grey/grau			SMC		

52

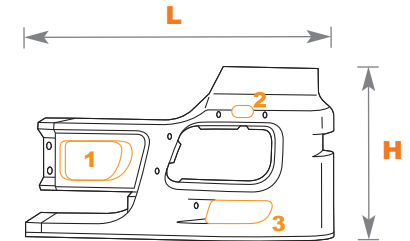

Legenda:
Key:
Legende:

- 1. Foro presa aria
Air intake
Luftausschnitt
- 2. Foro tergi faro
Headlight wipers
Scheinwerferreinigungsanlage
- 3. Foro faro fendinebbia
Fog lamp hole
Nebelscheinwerferausschnitt

Codice Covind	Covind References	Covind Art. Nr.	Codice Originale	O.E. References	Vergleichs-Nr.	1	2	3	L	H	Peso	Weight	Gewicht	Colore	Color	Farbe	Materiale	Material	Material
943/ 52	d/rh/rechts		9438806372			✓	✓	x	1005 mm	615 mm	5,200	Kg		grigio/grey/grau			SMC		
943/ 53	s/lh/links		9438806272			✓	✓	x	1005 mm	615 mm	5,460	Kg		grigio/grey/grau			SMC		

(*) c/foro tergifaro - s/fori fendinebbia
with headlight wipers - without foglamp holes
mit Scheinwerferreinigungsanlage
ohne Nebelscheinwerferausschnitt

(°) c/foro tergifaro - c/fori fendinebbia
with headlight wipers - with foglamp holes
mit Scheinwerferreinigungsanlage
mit Nebelscheinwerferausschnitt

943/ 56(*)

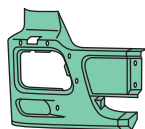

943/ 57(*)

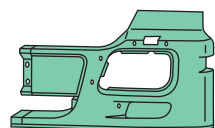

943/ 66(°)

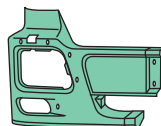

943/ 67(°)

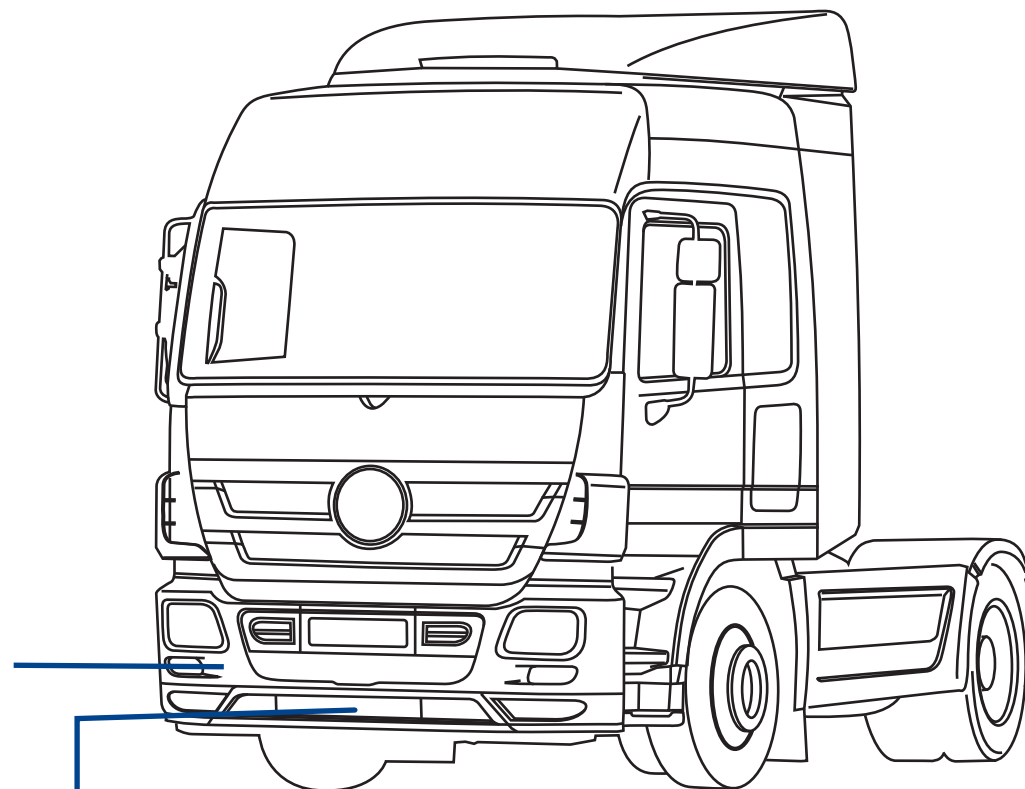
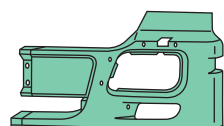

943/116
basso - low - niedrig



943/115
basso - low - niedrig



943/117
basso - low - niedrig



943/103

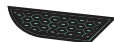

943/106



943/105



943/107



943/104



195

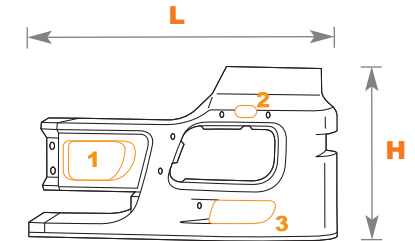

Legenda:
Key:
Legende:

- 1. Foro presa aria
Air intake
Luftausschnitt
- 2. Foro tergi faro
Headlight wipers
Scheinwerferreinigungsanlage
- 3. Foro faro fendinebbia
Fog lamp hole
Nebelscheinwerferausschnitt

Codice Covind	Covind References	Covind Art. Nr.	Codice Originale	O.E. References	Vergleichs-Nr.	1	2	3	L	H	Peso	Weight	Gewicht	Colore	Color	Farbe	Materiale	Material	Material
943/ 56	d/rh/rechts		9438801570			x	✓	x	1005 mm	615 mm	5,800			grigio/grey/grau			SMC		
943/ 57	s/lh/links		9438801470			x	✓	x	1005 mm	615 mm	5,800			grigio/grey/grau			SMC		

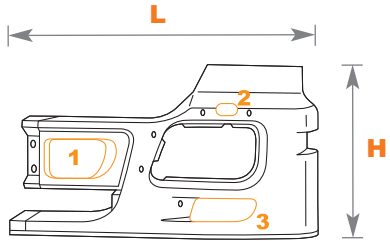

Legenda:
Key:
Legende:

1. Foro presa aria
Air intake
Luftausschnitt

2. Foro tergi faro
Headlight wipers
Scheinwerferreinigungsanlage

3. Foro faro fendinebbia
Fog lamp hole
Nebelscheinwerferausschnitt



Codice Covind	Covind References	Covind Art. Nr.	Codice Originale	O.E. References	Vergleichs-Nr.	1	2	3	L	H	Peso	Weight	Gewicht	Colore	Color	Farbe	Materiale	Material	Material
943/ 66	d/rh/rechts		9438801770			x	✓	✓	1005 mm	565 mm	5,650			grigio/grey/grau			SMC		
943/ 67	s/lh/links		9438801670			x	✓	✓	1005 mm	565 mm	5,650			grigio/grey/grau			SMC		

943/ 78
 c/foro fendinebbia
 c/presa d'aria - plastica
 with fog lamp hole
 with air intake - plastic
 mit Nebelscheinwerferauschnitt
 mit Luftausschnitt - Kunststoff

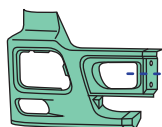

943/ 72

943/ 79
 c/foro fendinebbia
 c/presa d'aria - plastica
 with fog lamp hole
 with air intake - plastic
 mit Nebelscheinwerferauschnitt
 mit Luftausschnitt - Kunststoff



943/ 73

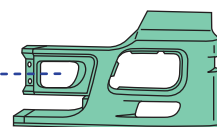

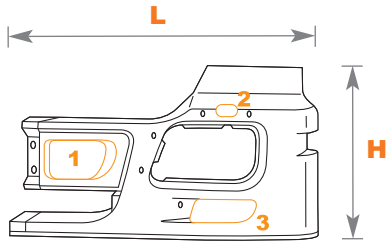

Legenda:
Key:
Legende:

1. Foro presa aria
Air intake
Luftausschnitt

2. Foro tergi faro
Headlight wipers
Scheinwerferreinigungsanlage

3. Foro faro fendinebbia
Fog lamp hole
Nebelscheinwerferausschnitt



57

Codice Covind	Covind References	Covind Art. Nr.	Codice Originale	O.E. References	Vergleichs-Nr.	1	2	3	L	H	Peso	Weight	Gewicht	Colore	Color	Farbe	Materiale	Material	Material
943/ 78	d/rh/rechts		9438806172			✓	x	✓	1005 mm	615 mm	5,710			grigio/grey/grau			SMC		
943/ 79	s/lh/links		9438806072			✓	x	✓	1005 mm	615 mm	5,515			grigio/grey/grau			SMC		



- ▲ IT Stampo femmina in acciaio temprato per la realizzazione del frontale per il veicolo Scania V8 ultimo tipo
- UK Mould finishing process for the production of the front of the vehicle Scania V8 (last model)
- DE Geöffnete Stahlform für die Produktion der vorderseite des Fahrzeugs Scania V8 letzte Typ (Modell)



- ▲ IT Lavorazione dello stampo maschio per la produzione del frontale per il veicolo Scania V8 ultimo tipo
- UK Mould finishing process for the production of the front of the vehicle Scania V8(last model)
- DE Stahlform für die Produktion der vorderseite des Fahrzeugs Scania V8 letzte Typ (Modell)

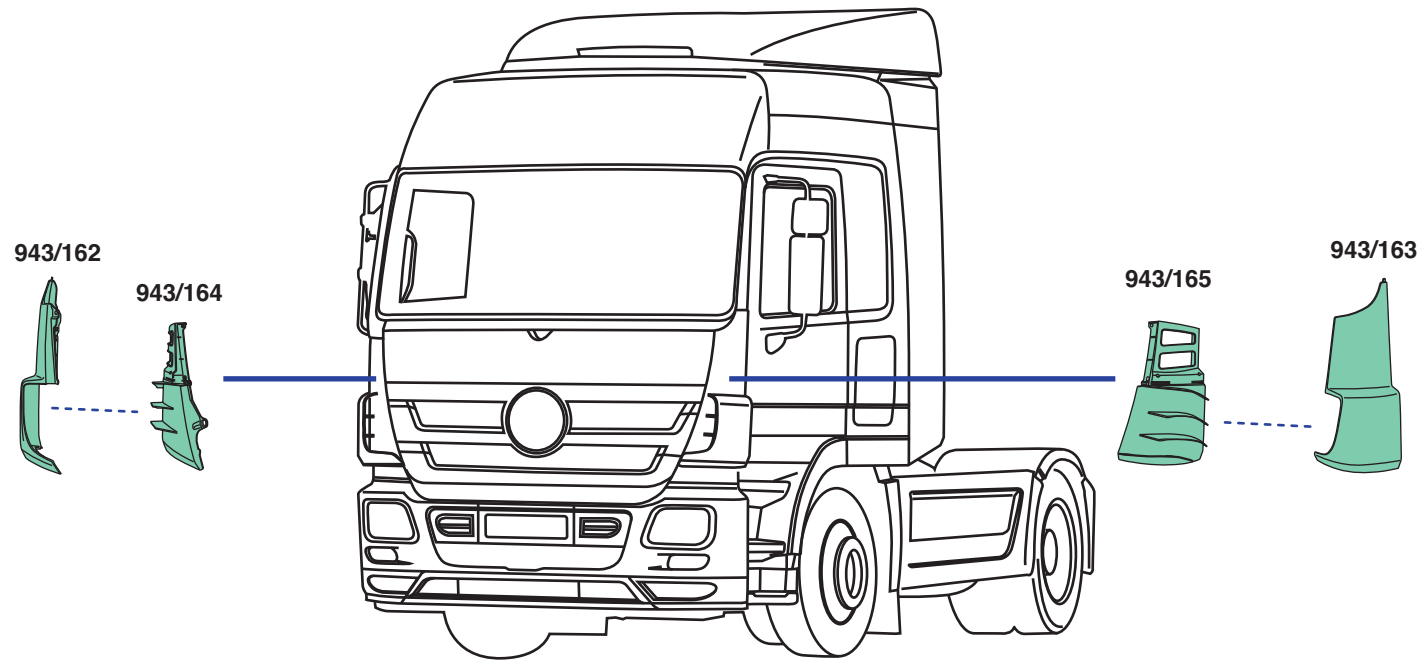

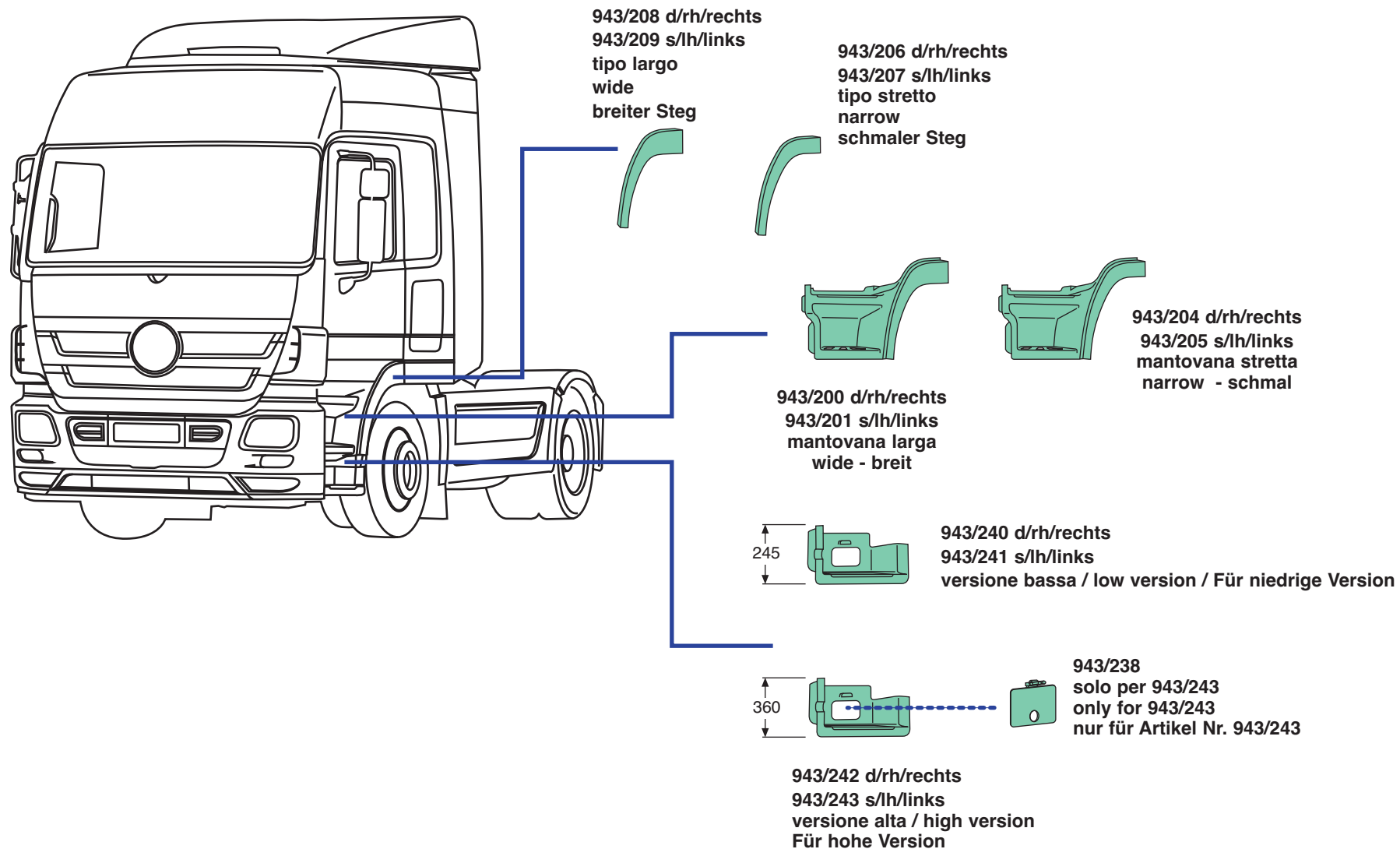

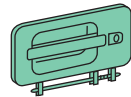
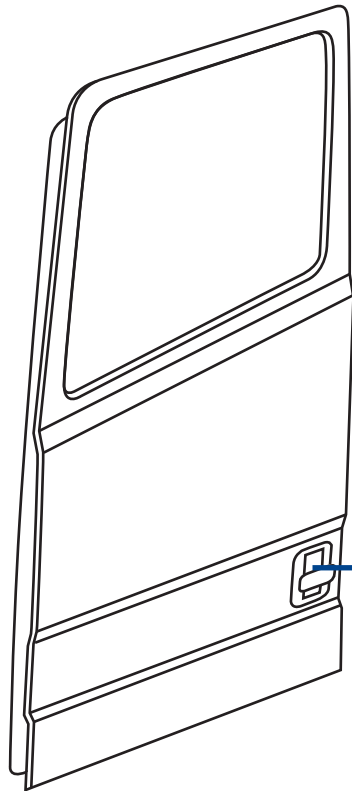

941/148 d/rh/rechts
941/149 s/lh/links
s/chiave
without key
ohne Schlüssel

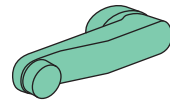
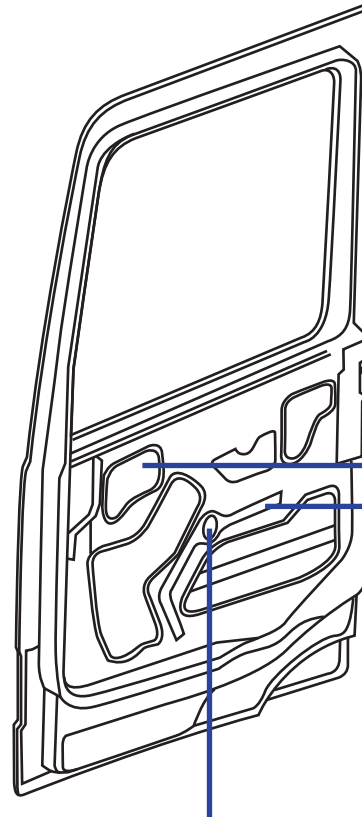

941/197 d/s
rh/lh
rechts/links

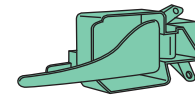

941/172 d/rh/rechts
941/173 s/lh/links
per alzavetro manuale
for window lifter-manual
manuell

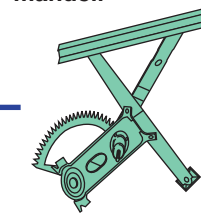

941/174 d/rh/rechts
941/175 s/lh/links
manuale
manual
manuell

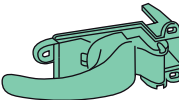
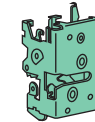

941/176 d/rh/rechts
941/177 s/lh/links

943/172 d/rh/rechts
943/173 s/lh/links
per alzavetro elettrico
for window lifter-electric
elektrisch

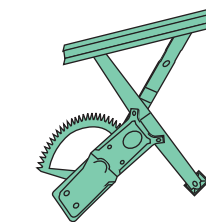

943/174 d/rh/rechts
943/175 s/lh/links
elettrico s/motorino
electric without motor
elektrisch ohne Motor

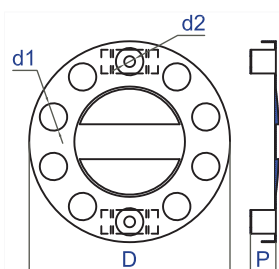

930/022 d/rh/rechts • 930/023 s/lh/links

D	∅ 425 mm	P	50 mm
d1 nr.	10	d1 ∅	58 mm
d2 nr.	2	d2 ∅	22,5 mm
Ventilata		si/yes/Ja	
Ventilated/Belüftet			
Colore/Colours/Farbe	cromato/chrome/verchromt		
Materiale/Material	acciaio inox e plastica stainless steel and plastic Edelstahl und Kunststoff		
Kg	1,235		

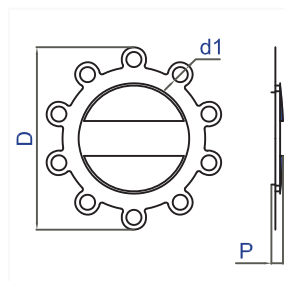

930/122 d/rh/rechts • 930/123 s/lh/links

D	∅ 387 mm	P	30 mm
d1 nr.	10	d1 ∅	32 mm
Ventilata		si/yes/Ja	
Ventilated/Belüftet			
Colore	cromato e nero/chrome and black verchromt und schwarz		
Colours/Farbe			
Materiale/Material	acciaio inox e plastica stainless steel and plastic Edelstahl und Kunststoff		
Kg	0,655		

930/032 - Tappo copri Bullone • Bolt cover • Radmutterkappen

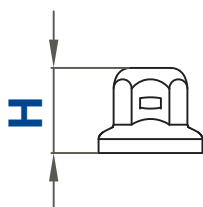

H	45 mm
Per bulloni ∅ / bolt ∅	32 mm
Schlüsselweite ∅	
Colore	cromato/chrome/verchromt
Colours/Farbe	
Materiale/Material	acciaio inox/stainless steel Edelstahl
Kg	0,025

930/132 - Tappo copri Bullone • Bolt cover • Radmutterkappen

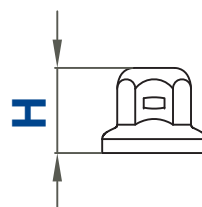

H	45 mm
Per bulloni ∅ / bolt ∅	32 mm
Schlüsselweite ∅	
Colore	cromato/chrome/verchromt
Colours/Farbe	
Materiale/Material	plastica/plastic/Kunststoff
Kg	0,014

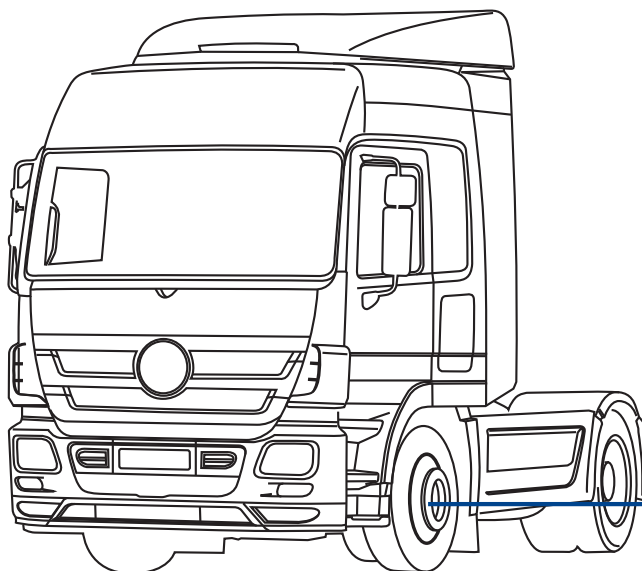

930/022 d/rh/rechts
930/023 s/lh/links
c/scritta
with written
mit Emblem



930/032
acciaio inox
stainless steel
Edelstahl



930/132
plastica - cromato
plastic - chrome
Kunststoff - verchromt



930/122 d/rh/rechts
930/123 s/lh/links
cerchi in lega
alloy wheels
Leichtmetallabdeckung

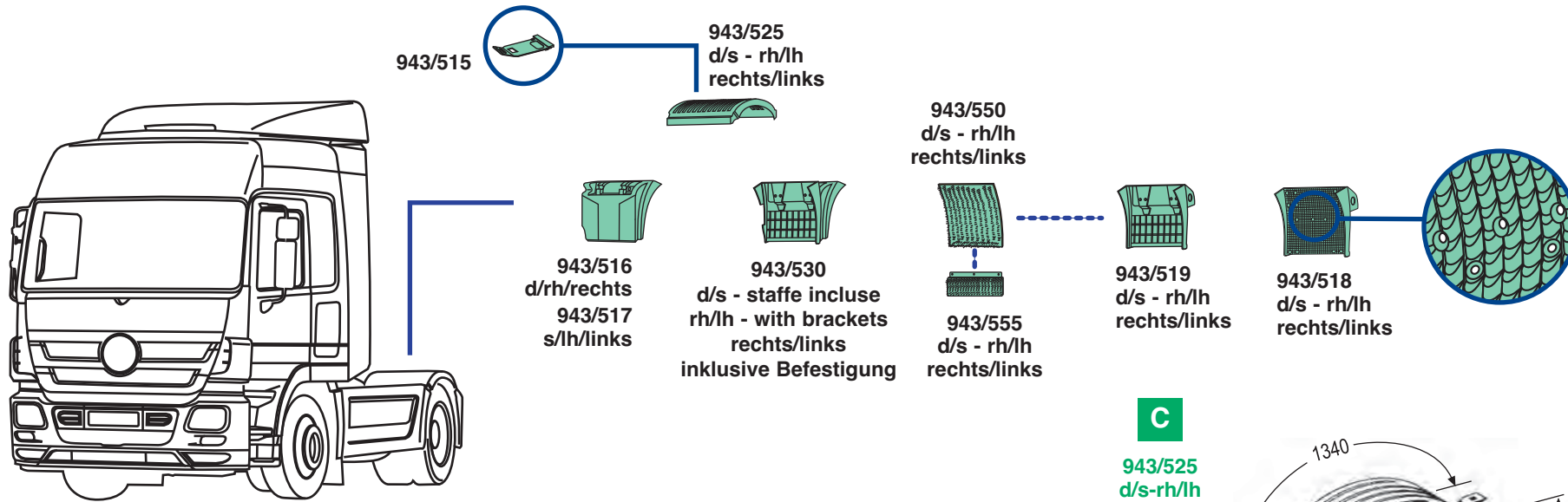

- A** con anti-spray/with anti-spray/mit Spritzschutz
- B** senza anti-spray/without anti-spray/ohne Spritzschutz
- C** con cinghietti/with stretcher/mit Befestigungsgummi
- D** senza cinghietti/without stretcher/ohne Befestigungsgummi

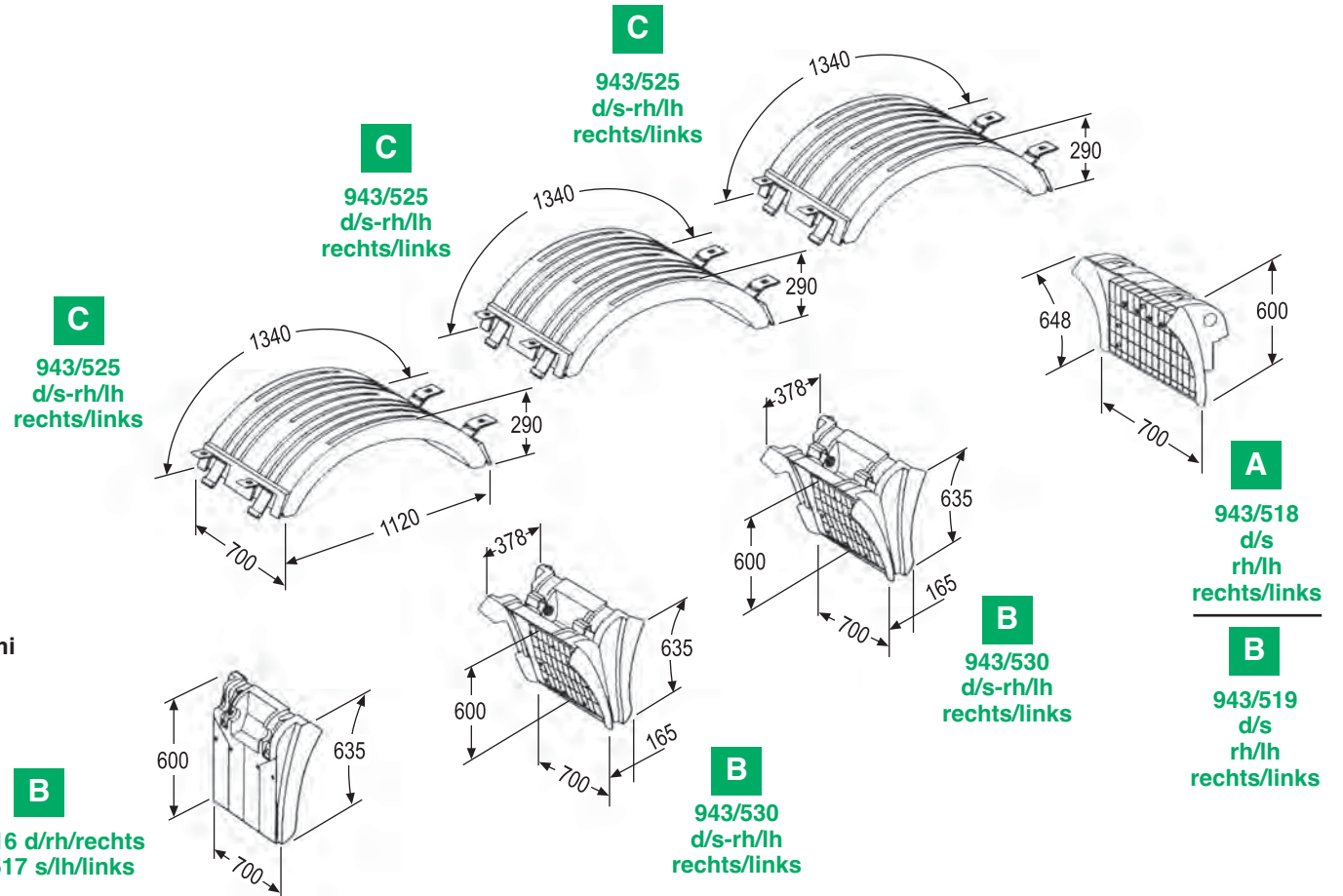

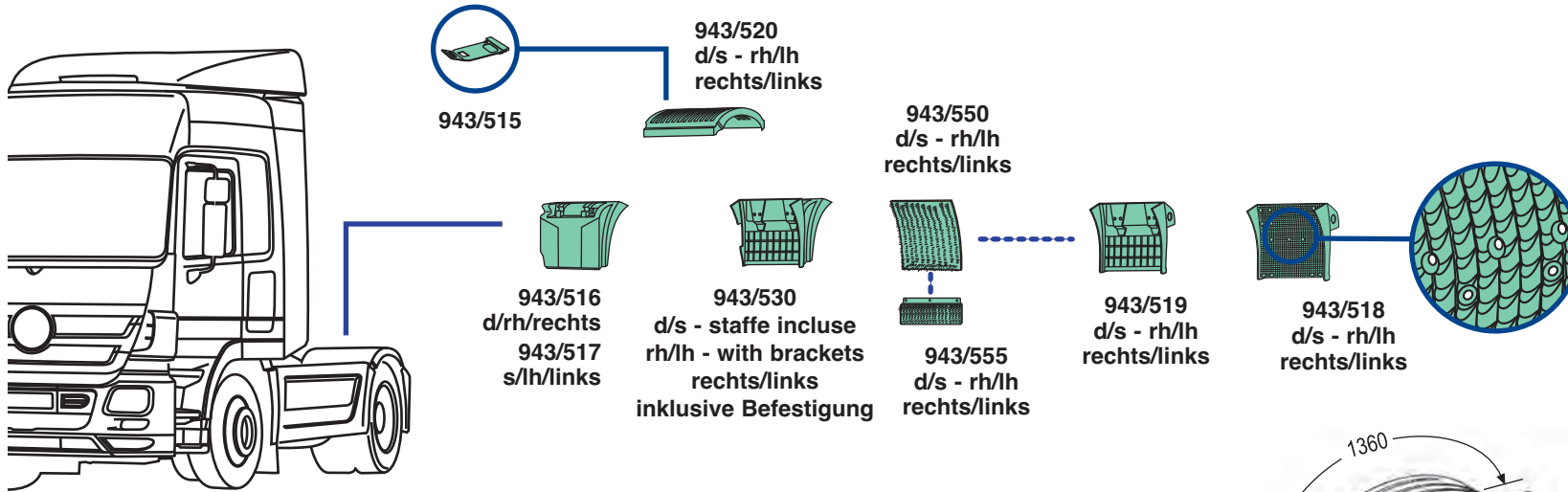

- A** con anti-spray/with anti-spray/mit Spritzschutz
- B** senza anti-spray/without anti-spray/ohne Spritzschutz
- C** con cinghietti/with stretcher/mit Befestigungsgummi
- D** senza cinghietti/without stretcher/ohne Befestigungsgummi

C
943/520
d/s-rh/lh
rechts/links

B
943/516 d/rh/rechts
943/517 s/lh/links

C
943/520
d/s-rh/lh
rechts/links

B
943/530
d/s-rh/lh
rechts/links

B
943/530
d/s-rh/lh
rechts/links

C
943/520
d/s-rh/lh
rechts/links

A
943/518
d/s
rh/lh
rechts/links

B
943/519
d/s
rh/lh
rechts/links

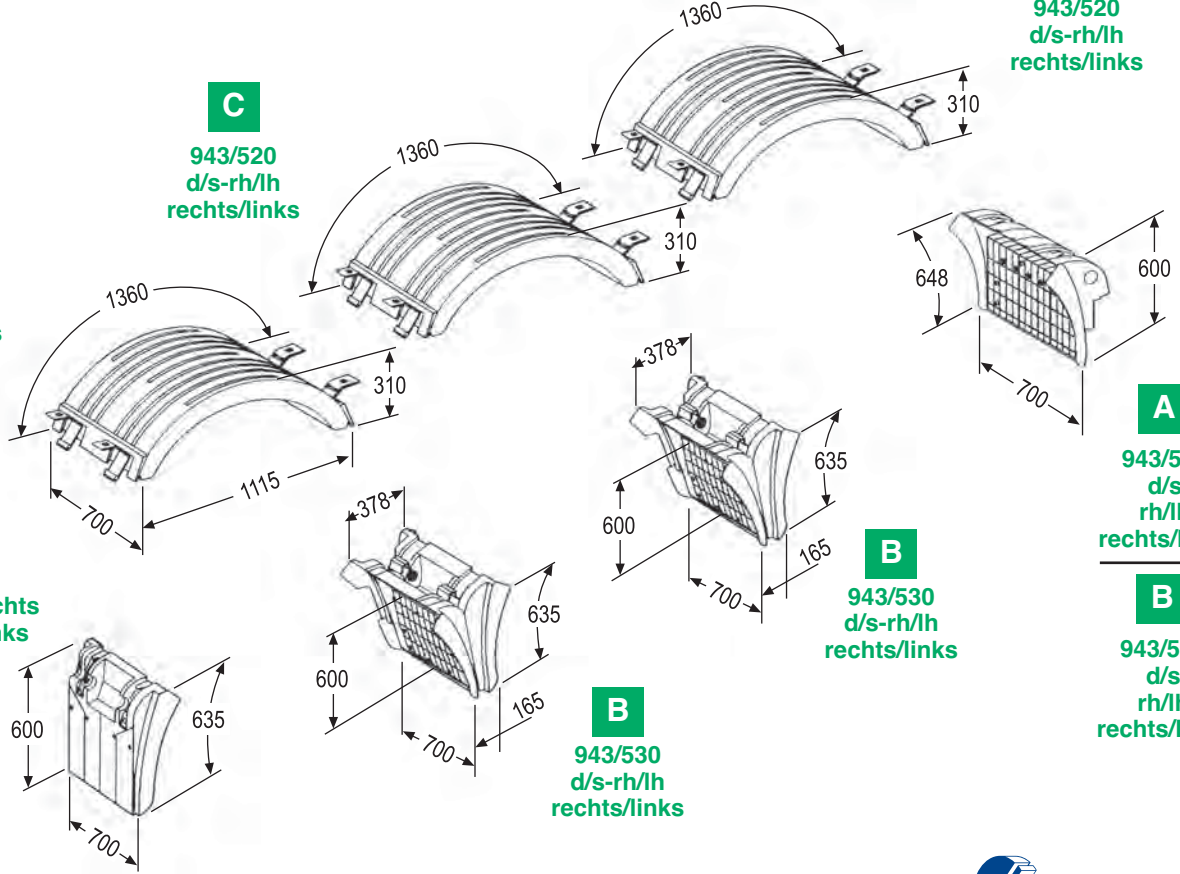

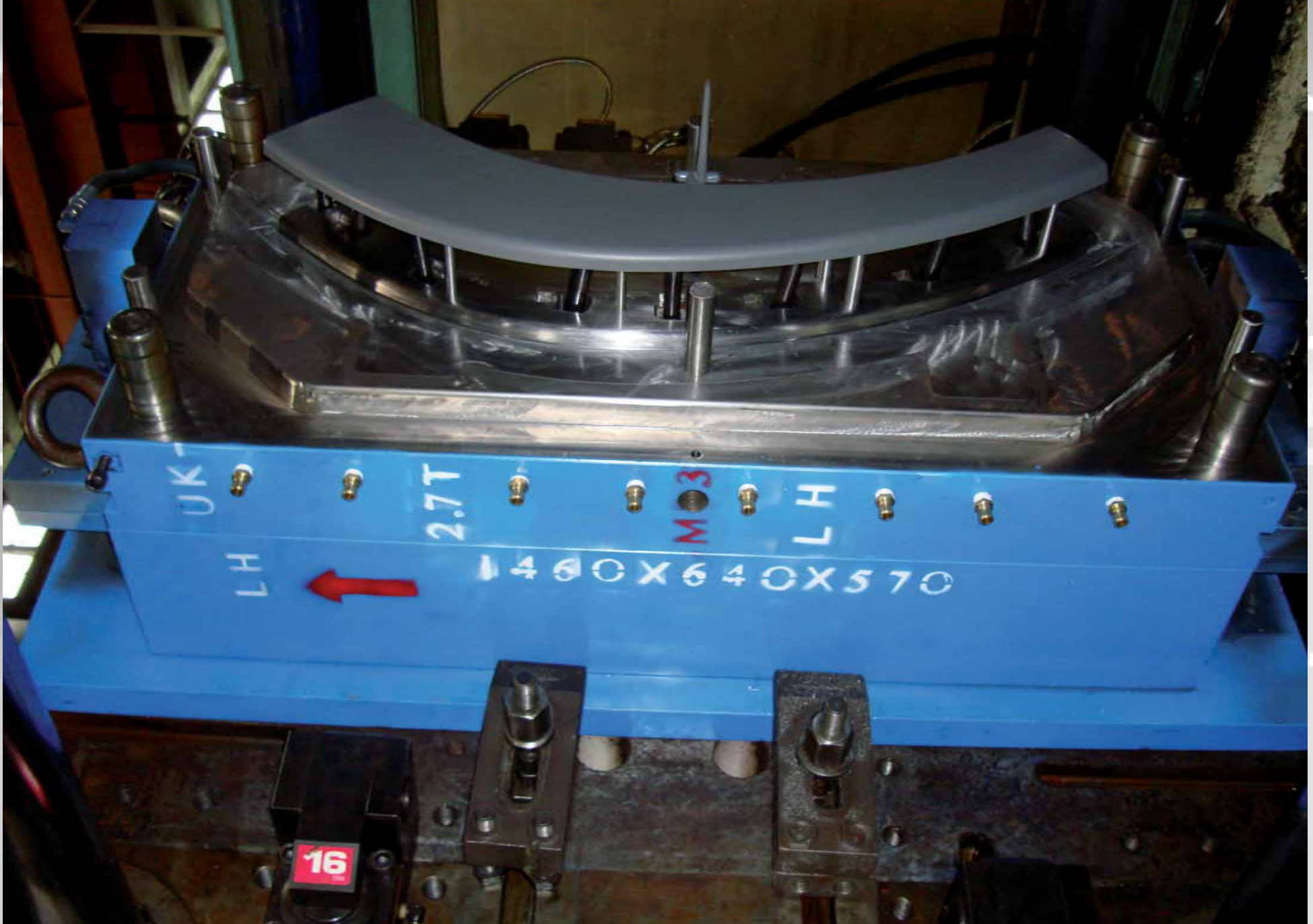

- ▲ IT Stampo in acciaio temprato per la realizzazione dell'appendice parafango
- UK Hardened steel mold for mudguard extension production
- DE Offene gehärtete Stahlform für Kotflügelblende

MERCEDES

MERCEDES-BENZ ACTROS 3
MEGA SPACE

67





- ▲ IT Processo di finitura stampo
- UK Mold finishing process
- DE Herstellung und Fräsung der Stahlform

943/ 92
c/presa d'aria
with air intake
mit Luftausschnitt

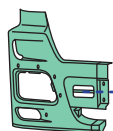

943/ 72



943/ 73



943/ 93
c/presa d'aria
with air intake
mit Luftausschnitt

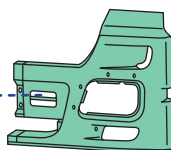

943/ 90
plastica
plastic
Kunststoff

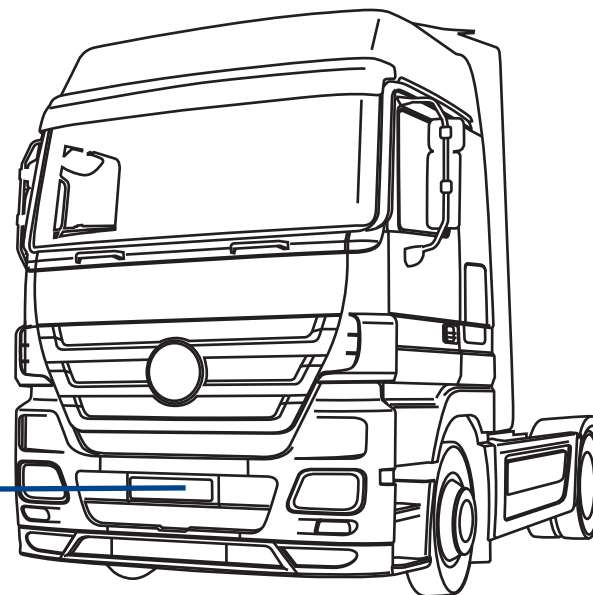

70

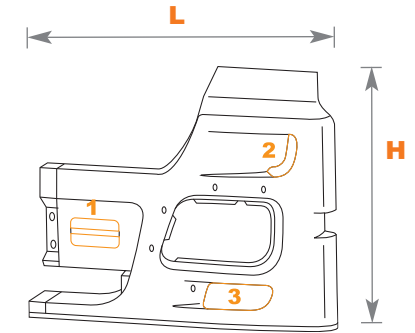

Legenda:
Key:
Legende:

- 1. Foro presa aria
Air intake
Luftausschnitt
- 2. Foro presa aria
Air intake
Luftausschnitt
- 3. Foro faro fendinebbia
Fog lamp hole
Nebelscheinwerferausschnitt

Codice Covind	Covind References	Covind Art. Nr.	Codice Originale	O.E. References	Vergleichs-Nr.	1	2	3	L	H	Peso	Weight	Gewicht	Colore	Color	Farbe	Materiale	Material	Material
943/ 92	d/rh/rechts		9438800104	-	9438804573	✓	✓	✓	1005 mm	615 mm	5,710			grigio/grey/grau			SMC		
943/ 93	s/lh/links		9438800004	-	9438804473	✓	✓	✓	1005 mm	615 mm	5,515			grigio/grey/grau			SMC		



- ▲ IT Lavorazione degli stampi per la produzione del frontale per il veicolo Scania V8 ultimo tipo
- UK Mould finishing process for the production of the front of the vehicle Scania V8 (last model)
- DE Bearbeitung von Formen für die Herstellung der vorderseite des Fahrzeugs Scania V8 letzte Typ (Modell)



- ▲ IT Stampo per lo stampaggio ad iniezione del semiparafango posteriore per il Volvo
- UK Mould for the production (through injection) of the mudguard
- DE Stahlform für die Herstellung (durch Spritzguss) der Hinterachskotflügel

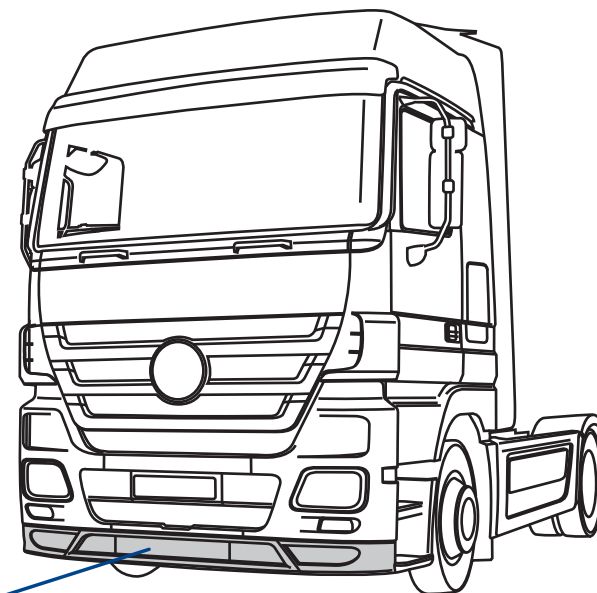

943/116
basso - low - niedrig



943/115
basso - low - niedrig

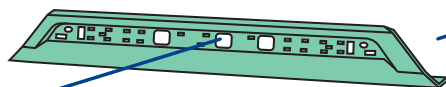

943/117
basso - low - niedrig

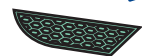
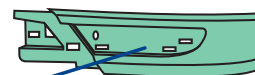

943/103

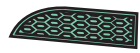

943/106



943/105



943/107



943/104



195

943/111
alto - high - hoch



943/110
alto - high - hoch

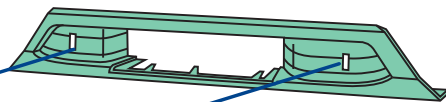

943/112
alto - high - hoch

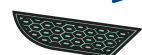
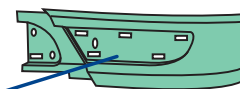

943/103



943/113



943/114



943/104

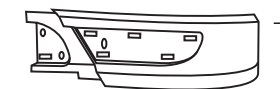

235

MERCEDES-BENZ ACTROS 3 MEGA SPACE

74

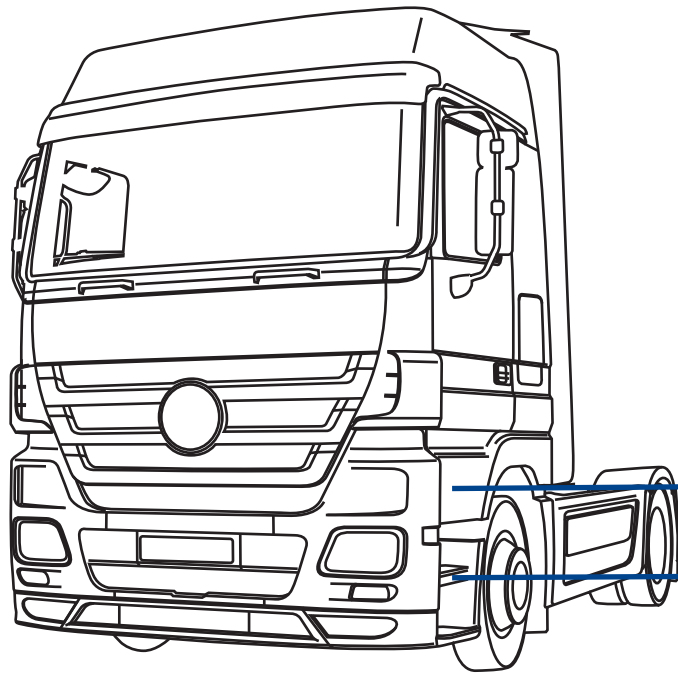

944/200 d/rh/rechts
944/201 s/lh/links

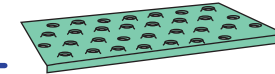
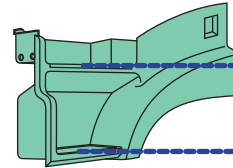

944/212
d/s - rh/lh - rechts/links

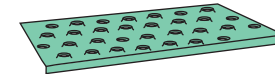

944/215
d/s - rh/lh - rechts/links

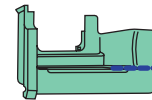

943/248 d/rh/rechts
943/249 s/lh/links

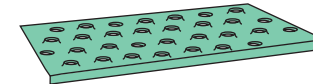

944/216
d/s - rh/lh - rechts/links

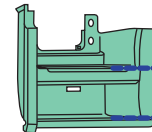

943/244 d/rh/rechts
943/245 s/lh/links

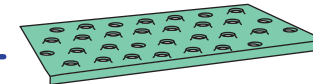

944/216
d/s - rh/lh - rechts/links

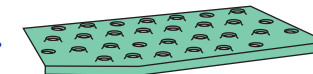

944/210 d/rh/rechts
944/211 s/lh/links

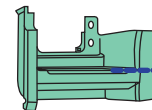

943/250 d/rh/rechts
943/251 s/lh/links

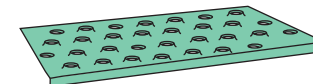

944/216
d/s - rh/lh - rechts/links

MERCEDES-BENZ ACTROS 3 MEGA SPACE

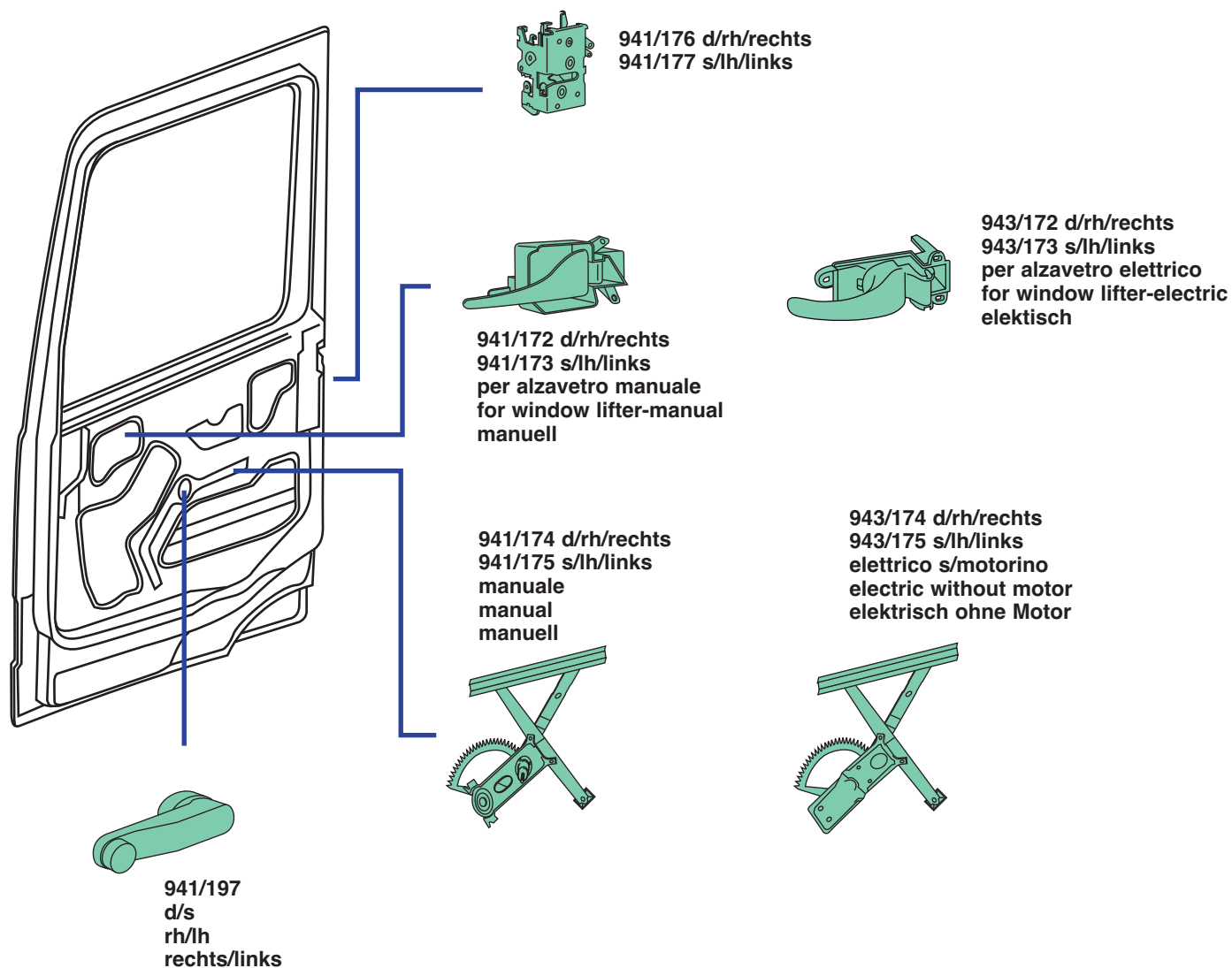

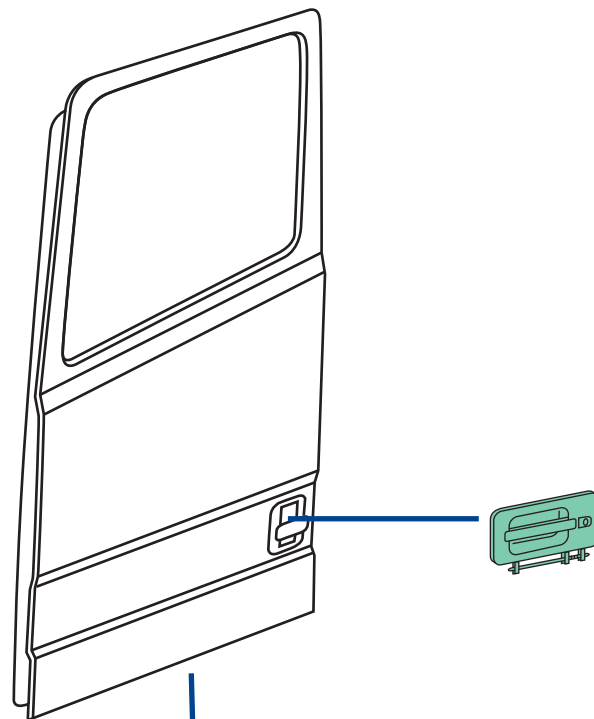

941/148 d/rh/rechts
941/149 s/lh/links
s/chiave
without key
ohne Schlüssel

943/ 6 d/rh/rechts
943/ 7 s/lh/links

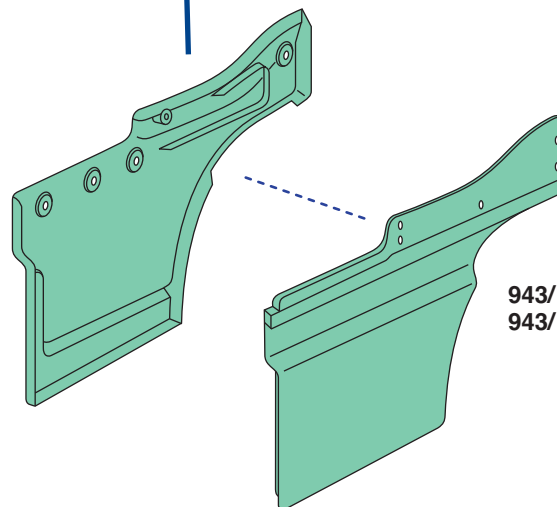

943/ 4 d/rh/rechts
943/ 5 s/lh/links

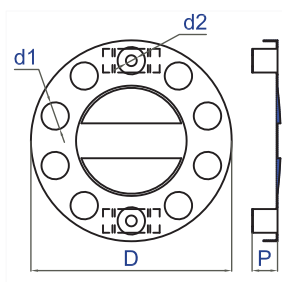

930/022 d/rh/rechts · 930/023 s/lh/links

D ø 425 mm	P 50 mm
d1 nr. 10	d1 ø 58 mm
d2 nr. 2	d2 ø 22,5 mm
Ventilata	si/yes/Ja
Ventilated/Belüftet	
Colore/	cromato/chrome/verchromt
Colours/Farbe	
Materiale/Material	acciaio inox e plastica stainless steel and plastic Edelstahl und Kunststoff
Kg	1,235

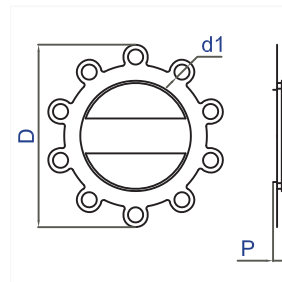

930/122 d/rh/rechts · 930/123 s/lh/links

D ø 387 mm	P 30 mm
d1 nr. 10	d1 ø 32 mm
Ventilata	si/yes/Ja
Ventilated/Belüftet	
Colore	cromato e nero/chrome and black
Colours/Farbe	verchromt und schwarz
Materiale/Material	acciaio inox e plastica stainless steel and plastic Edelstahl und Kunststoff
Kg	0,655

930/032 - Tappo copri Bullone · Bolt cover · Radmutterkappen

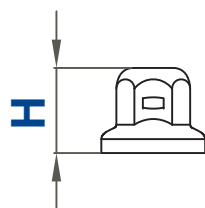

H	45 mm
Per bulloni ø / bolt ø	32 mm
Schlüsselweite ø	
Colore	cromato/chrome/verchromt
Colours/Farbe	
Materiale/Material	acciaio inox/stainless steel Edelstahl
Kg	0,025

930/132 - Tappo copri Bullone · Bolt cover · Radmutterkappen

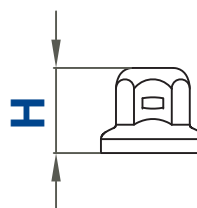

H	45 mm
Per bulloni ø / bolt ø	32 mm
Schlüsselweite ø	
Colore	cromato/chrome/verchromt
Colours/Farbe	
Materiale/Material	plastica/plastic/Kunststoff
Kg	0,014

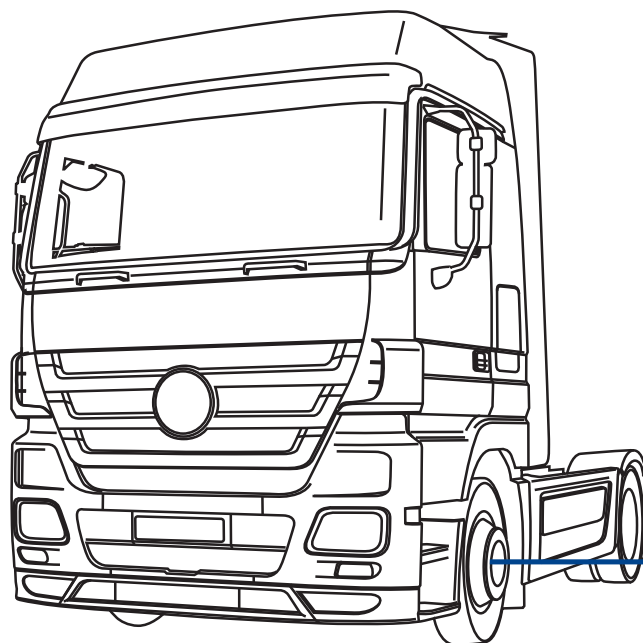

930/022 d/rh/rechts
930/023 s/lh/links
c/scritta
with written
mit Emblem



930/032
acciaio inox
stainless steel
Edelstahl
930/132
plastica - cromato
plastic - chrome
Kunststoff - verchromt



930/122 d/rh/rechts
930/123 s/lh/links
cerchi in lega
alloy wheels
Leichtmetallabdeckung



MERCEDES·BENZ ACTROS 3 MEGA SPACE

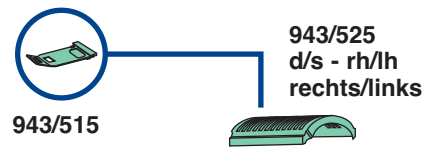

943/525
d/s - rh/lh
rechts/links

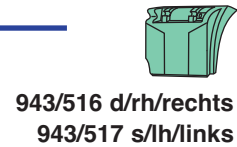

943/530
d/s - stoffe incluse
rh/lh - with brackets
rechts/links
inklusive Befestigung

943/550
d/s - rh/lh
rechts/links



943/555
d/s - rh/lh
rechts/links



943/519
d/s - rh/lh
rechts/links

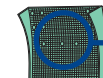

943/518
d/s - rh/lh
rechts/links

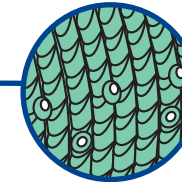

C

943/525
d/s-rh/lh-rechts/links

C

943/525
d/s-rh/lh-rechts/links

C

943/525
d/s-rh/lh-rechts/links

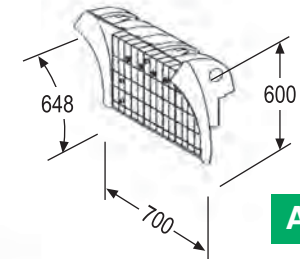
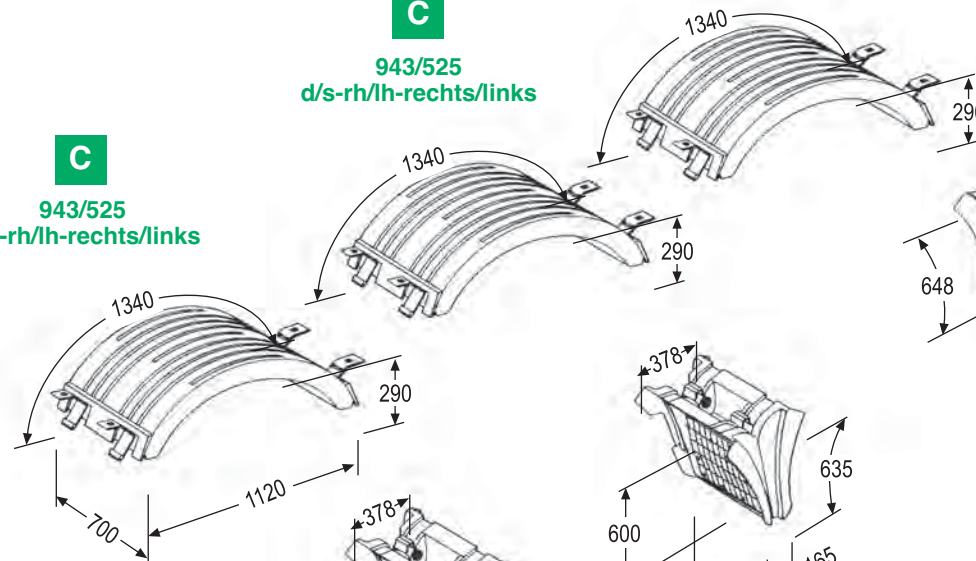

A

943/518
d/s
rh/lh
rechts/links

B

943/530
d/s-rh/lh
rechts/links

B

943/530
d/s-rh/lh
rechts/links

B

943/516 d/rh/rechts
943/517 s/lh/links

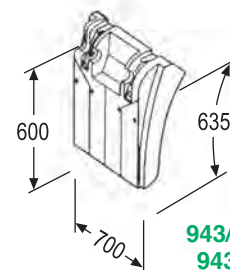

78

- A** con anti-spray/with anti-spray/mit Spritzschutz
- B** senza anti-spray/without anti-spray/ohne Spritzschutz
- C** con cinghietti/with stretcher/mit Befestigungsgummi
- D** senza cinghietti/without stretcher/ohne Befestigungsgummi

MERCEDES·BENZ ACTROS 3 MEGA SPACE

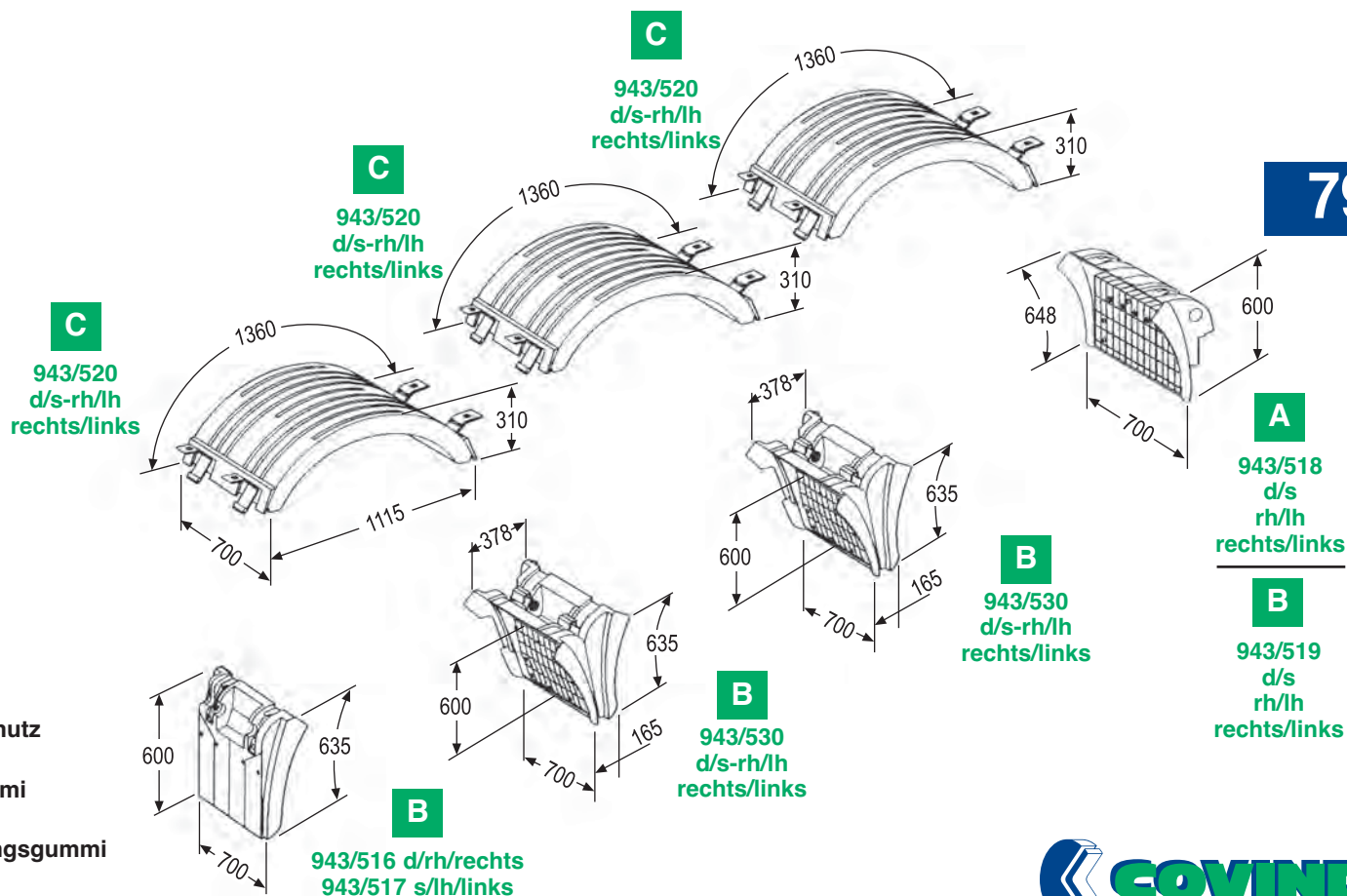
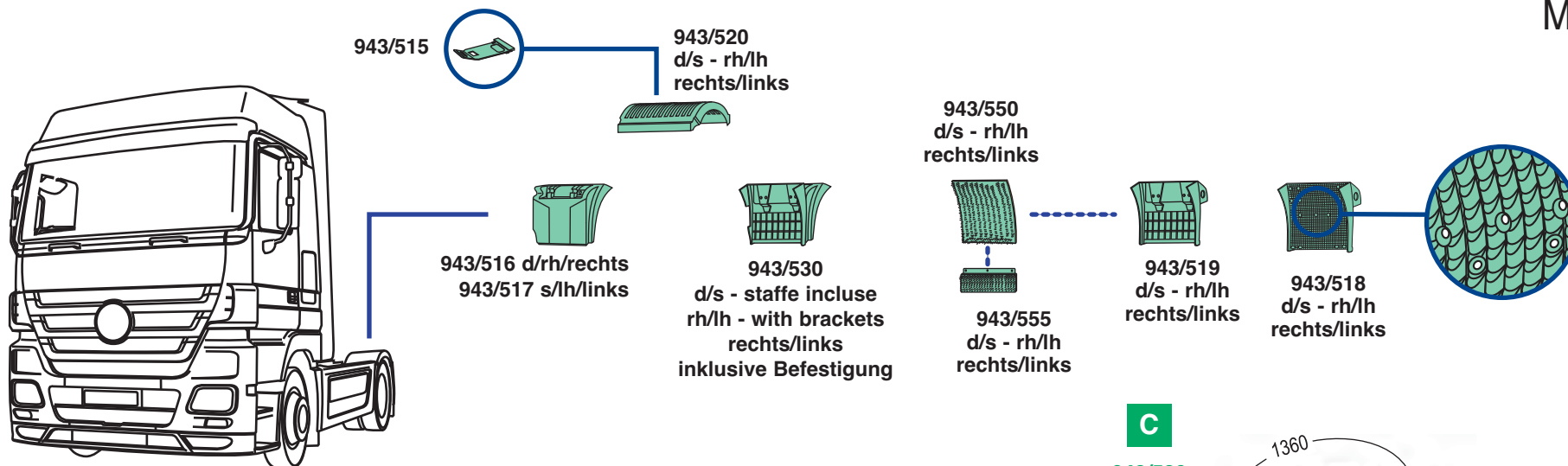

79

- A** con anti-spray/with anti-spray/mit Spritzschutz
- B** senza anti-spray/without anti-spray/ohne Spritzschutz
- C** con cinghietti/with stretcher/mit Befestigungsgummi
- D** senza cinghietti/without stretcher/ohne Befestigungsgummi

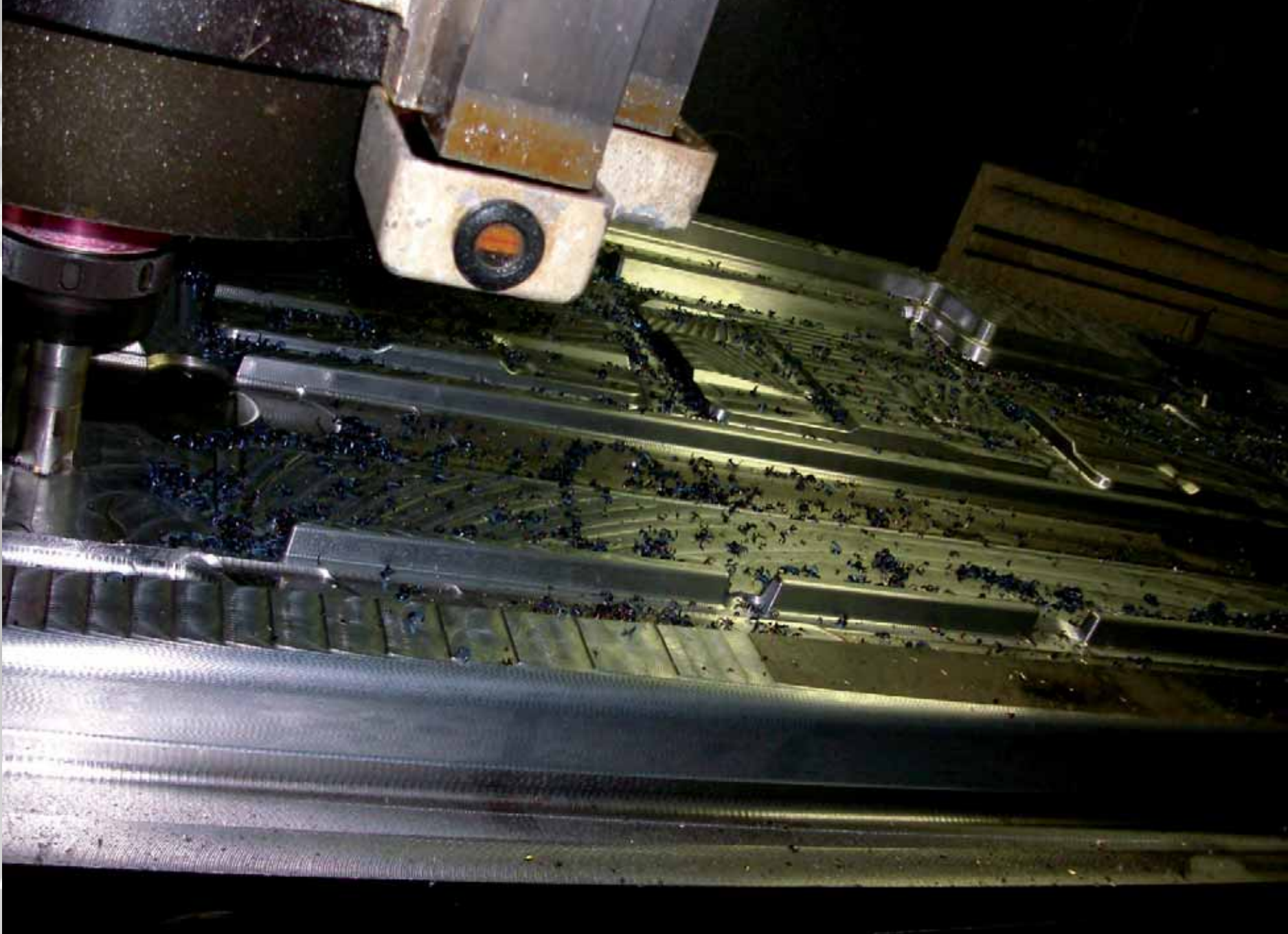

- ▲ IT Una fresatrice a controllo numerico (cnc) in lavorazione su uno stampo per paraurti
- UK Numerical control milling machine working on a mold for bumper
- DE Fräsebearbeitung einer Stahlform für die Stossstangenherstellung

MERCEDES

MERCEDES-BENZ ACTROS 2
seconda serie / second version / zweite Serie



81

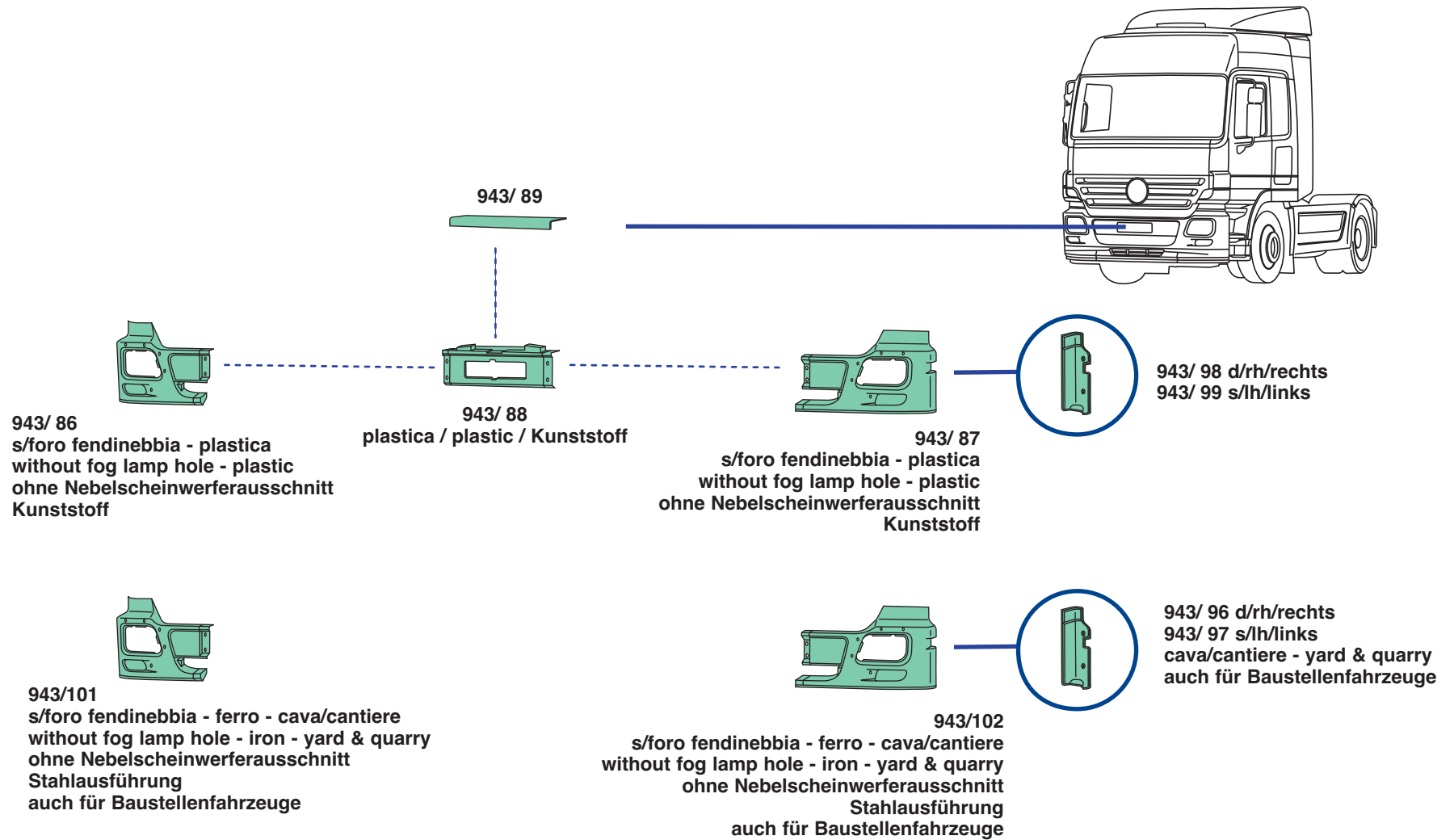

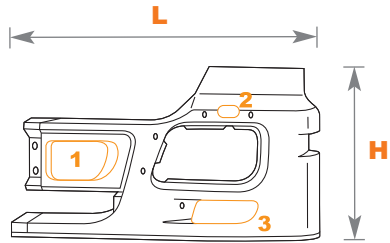

Legenda:
Key:
Legende:

1. Foro presa aria
Air intake
Luftausschnitt

2. Foro tergi faro
Headlight wipers
Scheinwerferreinigungsanlage

3. Foro faro fendinebbia
Fog lamp hole
Nebelscheinwerferausschnitt



Codice Covind	Covind References	Covind Art. Nr.	Codice Originale	O.E. References	Vergleichs-Nr.	1	2	3	L	H	Peso	Weight	Gewicht	Colore	Color	Farbe	Materiale	Material	Material
943/ 86	d/rh/rechts		9438800370 - 9438809972			x	x	x	1005 mm	615 mm	5,605 kg.			grigio/grey/grau			SMC		
943/ 87	s/lh/links		9438800270 - 9438809872			x	x	x	1005 mm	615 mm	5,805 kg.			grigio/grey/grau			SMC		

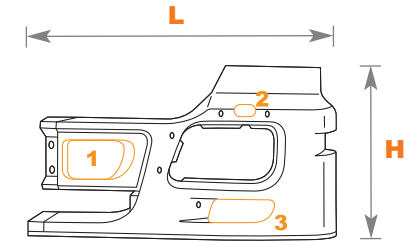

Legenda:
Key:
Legende:

1. Foro presa aria
Air intake
Luftausschnitt

2. Foro tergi faro
Headlight wipers
Scheinwerferreinigungsanlage

3. Foro faro fendinebbia
Fog lamp hole
Nebelscheinwerferausschnitt

Codice Covind	Covind References	Covind Art. Nr.	Codice Originale	O.E. References	Vergleichs-Nr.	1	2	3	L	H	Peso	Weight	Gewicht	Colore	Color	Farbe	Materiale	Material	Material
943/101	d/rh/rechts		9438800170 - 9438808170			x	x	x	1005 mm	635 mm	11,825 kg.			grigio/grey/grau			lamiera/sheet/Blech		
943/102	s/lh/links		9438800070 - 9438808070			x	x	x	1005 mm	635 mm	11,825 kg.			grigio/grey/grau			lamiera/sheet/Blech		

943/ 56

c/foro tergifaro - s/foro fendinebbia - plastica
with headlight wipers - without fog lamp hole - plastic
mit Scheinwerferreinigungsanlage
ohne Nebelscheinwerferausschnitt - Kunststoff

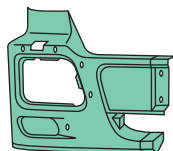

943/ 57

c/foro tergifaro - s/foro fendinebbia - plastica
with headlight wipers - without fog lamp hole - plastic
mit Scheinwerferreinigungsanlage
ohne Nebelscheinwerferausschnitt - Kunststoff

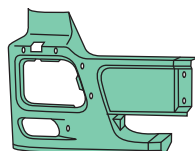
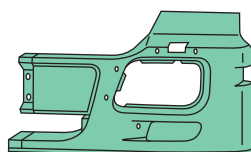

943/ 66

c/foro tergifaro - c/foro fendinebbia - plastica
with headlight wipers - with fog lamp hole - plastic
mit Scheinwerferreinigungsanlage
mit Nebelscheinwerferausschnitt - Kunststoff

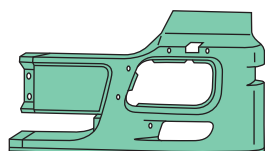

943/ 67

c/foro tergifaro - c/foro fendinebbia - plastica
with headlight wipers - with fog lamp hole - plastic
mit Scheinwerferreinigungsanlage
mit Nebelscheinwerferausschnitt - Kunststoff

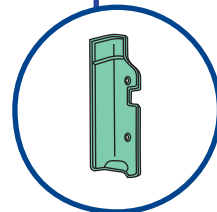

943/ 98 d/rh/rechts
943/ 99 s/lh/links

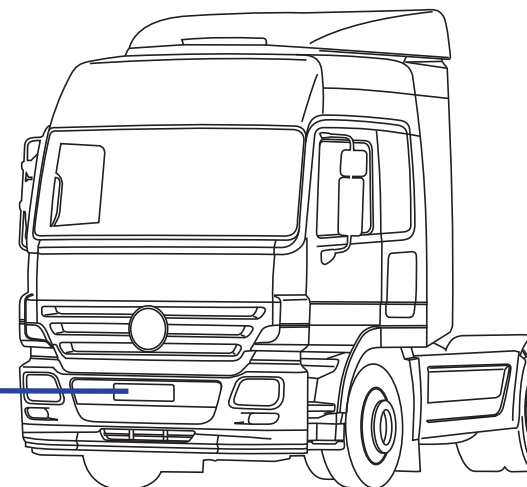

86

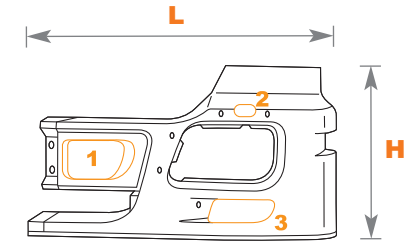

Legenda:
Key:
Legende:

- 1. Foro presa aria
Air intake
Luftausschnitt
- 2. Foro tergi faro
Headlight wipers
Scheinwerferreinigungsanlage
- 3. Foro faro fendinebbia
Fog lamp hole
Nebelscheinwerferausschnitt

Codice Covind	Covind References	Covind Art. Nr.	Codice Originale	O.E. References	Vergleichs-Nr.	1	2	3	L	H	Peso	Weight	Gewicht	Colore	Color	Farbe	Materiale	Material	Material
943/ 56	d/rh/rechts		9438801570			x	✓	x	1005 mm	615 mm	-			grigio/grey/grau			SMC		
943/ 57	s/lh/links		9438801470			x	✓	x	1005 mm	615 mm	-			grigio/grey/grau			SMC		

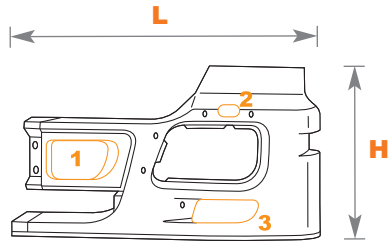

Legenda:
Key:
Legende:

1. Foro presa aria
Air intake
Luftausschnitt

2. Foro tergi faro
Headlight wipers
Scheinwerferreinigungsanlage

3. Foro faro fendinebbia
Fog lamp hole
Nebelscheinwerferausschnitt



Codice Covind	Covind References	Covind Art. Nr.	Codice Originale	O.E. References	Vergleichs-Nr.	1	2	3	L	H	Peso	Weight	Gewicht	Colore	Color	Farbe	Materiale	Material	Material
943/ 66 d/rh/rechts			9438801770			x	✓	✓	1005 mm	565 mm	-			grigio/grey/grau			SMC		
943/ 67 s/lh/links			9438801670			x	✓	✓	1005 mm	565 mm	-			grigio/grey/grau			SMC		

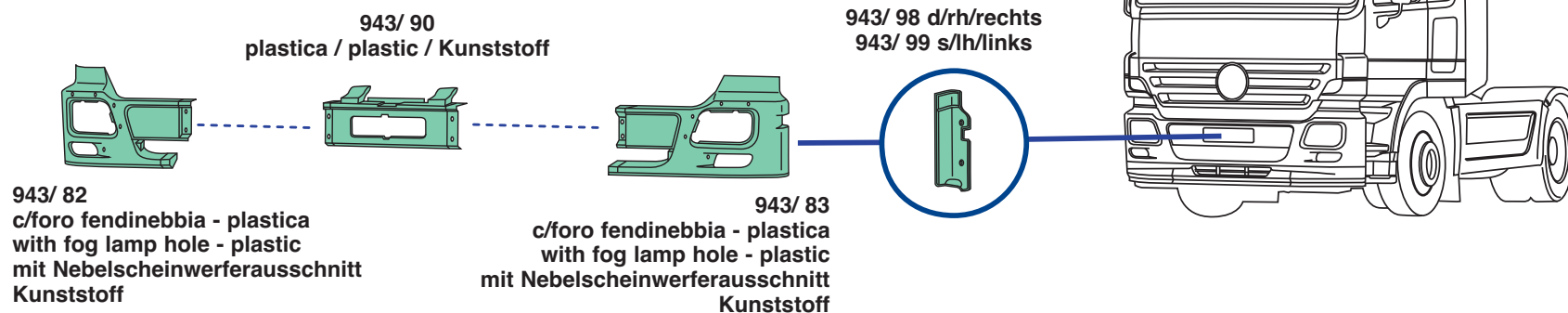

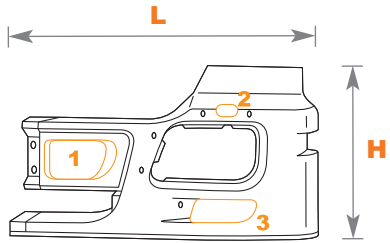

Legenda:
Key:
Legende:

1. Foro presa aria
Air intake
Luftausschnitt

2. Foro tergi faro
Headlight wipers
Scheinwerferreinigungsanlage

3. Foro faro fendinebbia
Fog lamp hole
Nebelscheinwerferausschnitt



Codice Covind	Covind References	Covind Art. Nr.	Codice Originale	O.E. References	Vergleichs-Nr.	1	2	3	L	H	Peso	Weight	Gewicht	Colore	Color	Farbe	Materiale	Material	Material
943/ 82	d/rh/rechts		9438800770 - 9438800173			x	x	✓	1005 mm	615 mm	5,850			grigio/grey/grau			SMC		
943/ 83	s/lh/links		9438800670 - 9438800073			x	x	✓	1005 mm	615 mm	5,850			grigio/grey/grau			SMC		

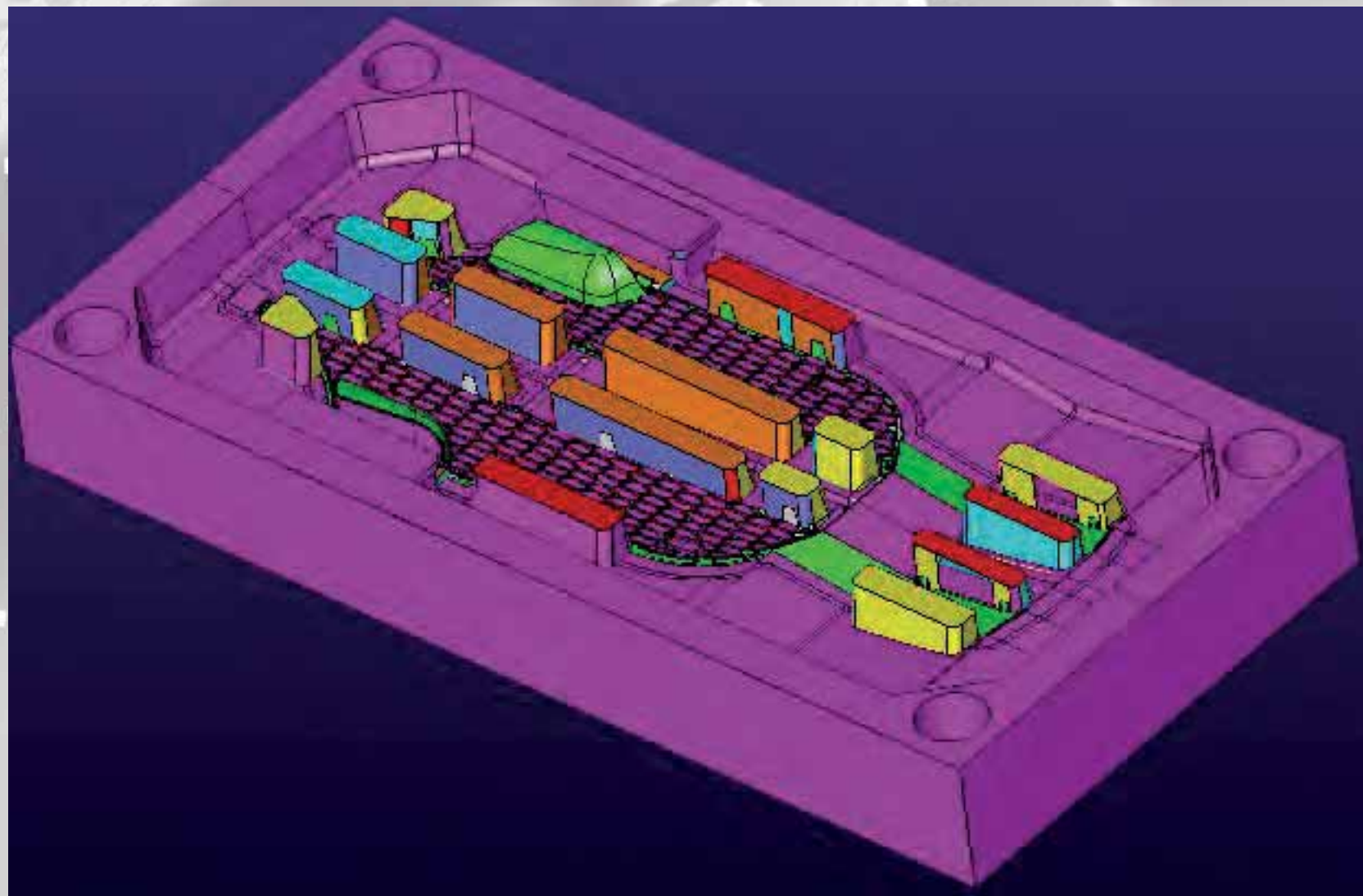

- ▲ IT Progetto in 3D dello stampo ad iniezione per la produzione di griglie
- UK 3-D Project for the mould to be used for the production of grille
- DE 3D-Projekt der Stahlform für die Herstellung von Grill

943/ 54
 s/foro fendinebbia
 s/foro tergifaro - s/presa aria
 -plastica-
 without fog lamp hole
 without headlight wipers
 without air intake
 -plastic-
 ohne Nebelscheinwerferausschnitt
 ohne Scheinwerferreinigungsanlage
 ohne Luftausschnitt
 Kunststoff

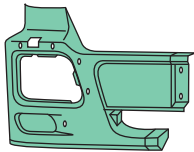
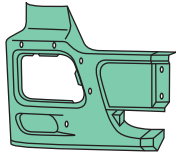

943/ 48
 s/foro fendinebbia
 c/foro tergifaro - s/presa aria
 -plastica-
 without fog lamp hole
 with headlight wipers
 without air intake
 -plastic-
 ohne Nebelscheinwerferausschnitt
 mit Scheinwerferreinigungsanlage
 ohne Luftausschnitt
 Kunststoff

943/ 55
 s/foro fendinebbia
 s/foro tergifaro - s/presa aria
 -plastica-
 without fog lamp hole
 without headlight wipers
 without air intake
 -plastic-
 ohne Nebelscheinwerferausschnitt
 ohne Scheinwerferreinigungsanlage
 ohne Luftausschnitt
 Kunststoff

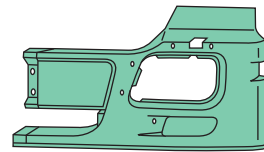
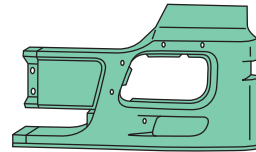

943/ 49
 s/foro fendinebbia
 c/foro tergifaro - s/presa aria
 -plastica-
 without fog lamp hole
 with headlight wipers
 without air intake
 -plastic-
 ohne Nebelscheinwerferausschnitt
 mit Scheinwerferreinigungsanlage
 ohne Luftausschnitt
 Kunststoff



943/ 98 d/rh/rechts
 943/ 99 s/lh/links

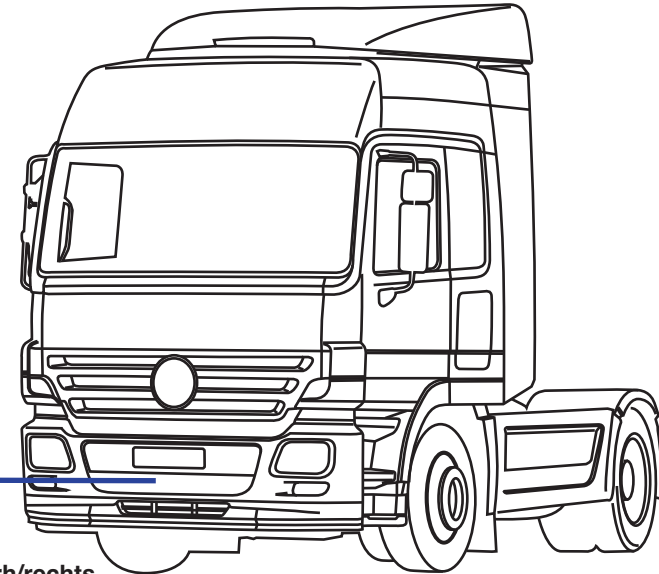

92

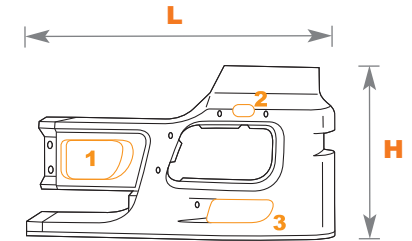

Legenda:
Key:
Legende:

1. Foro presa aria
Air intake
Luftausschnitt

2. Foro tergi faro
Headlight wipers
Scheinwerferreinigungsanlage

3. Foro faro fendinebbia
Fog lamp hole
Nebelscheinwerferausschnitt

Codice Covind	Covind References	Covind Art. Nr.	Codice Originale	O.E. References	Vergleichs-Nr.	1	2	3	L	H	Peso	Weight	Gewicht	Colore	Color	Farbe	Materiale	Material	Material
943/ 48	d/rh/rechts		9438804070			x	✓	x	1005 mm	565 mm	5,460			grigio/grey/grau			SMC		
943/ 49	s/lh/links		9438803970			x	✓	x	1005 mm	565 mm	5,730			grigio/grey/grau			SMC		

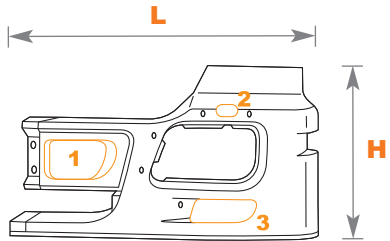

Legenda:
Key:
Legende:

1. Foro presa aria
Air intake
Luftausschnitt

2. Foro tergi faro
Headlight wipers
Scheinwerferreinigungsanlage

3. Foro faro fendinebbia
Fog lamp hole
Nebelscheinwerferausschnitt



Codice Covind	Covind References	Covind Art. Nr.	Codice Originale	O.E. References	Vergleichs-Nr.	1	2	3	L	H	Peso	Weight	Gewicht	Colore	Color	Farbe	Materiale	Material	Material
943/ 54	d/rh/rechts		9438803670			x	x	x	1005 mm	565 mm	5,520			grigio/grey/grau			SMC		
943/ 55	s/lh/links		9438803570			x	x	x	1005 mm	565 mm	5,480			grigio/grey/grau			SMC		

MERCEDES·BENZ ACTROS 2
seconda serie / second version / zweite Serie

943/124

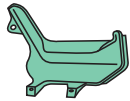

943/120



943/125

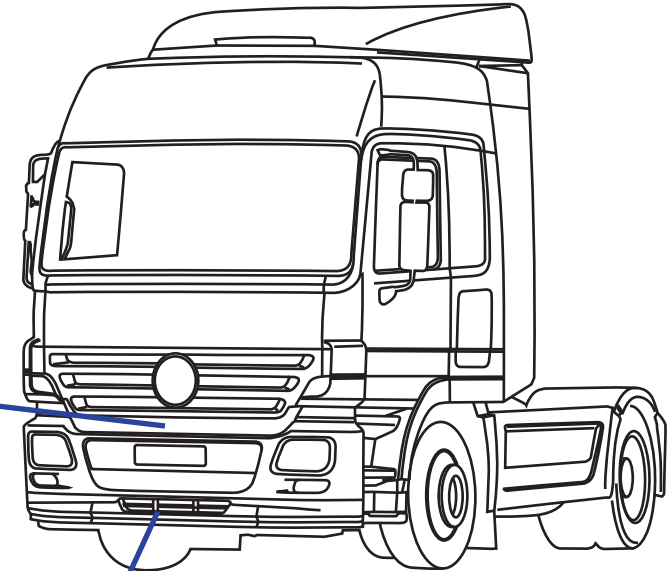

94



943/ 84

basso - low - niedrig

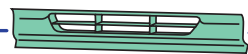

943/ 80

basso - low - niedrig



943/ 85

basso - low - niedrig

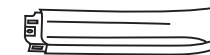

160

943/ 76
alto - high - hoch



943/ 75
alto - high - hoch



943/ 77
alto - high - hoch

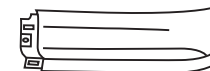

220

MERCEDES·BENZ ACTROS 2
seconda serie / second version / zweite Serie

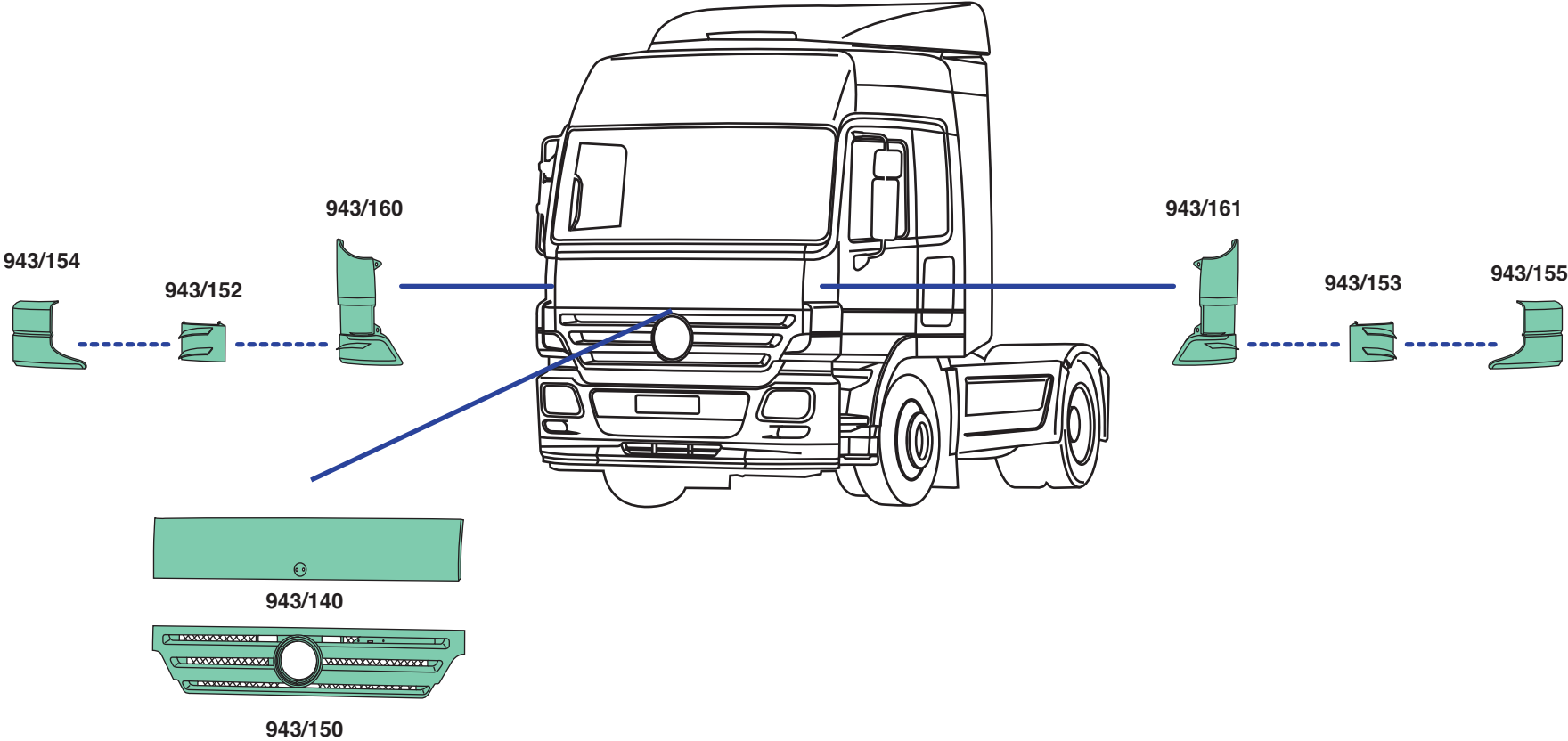

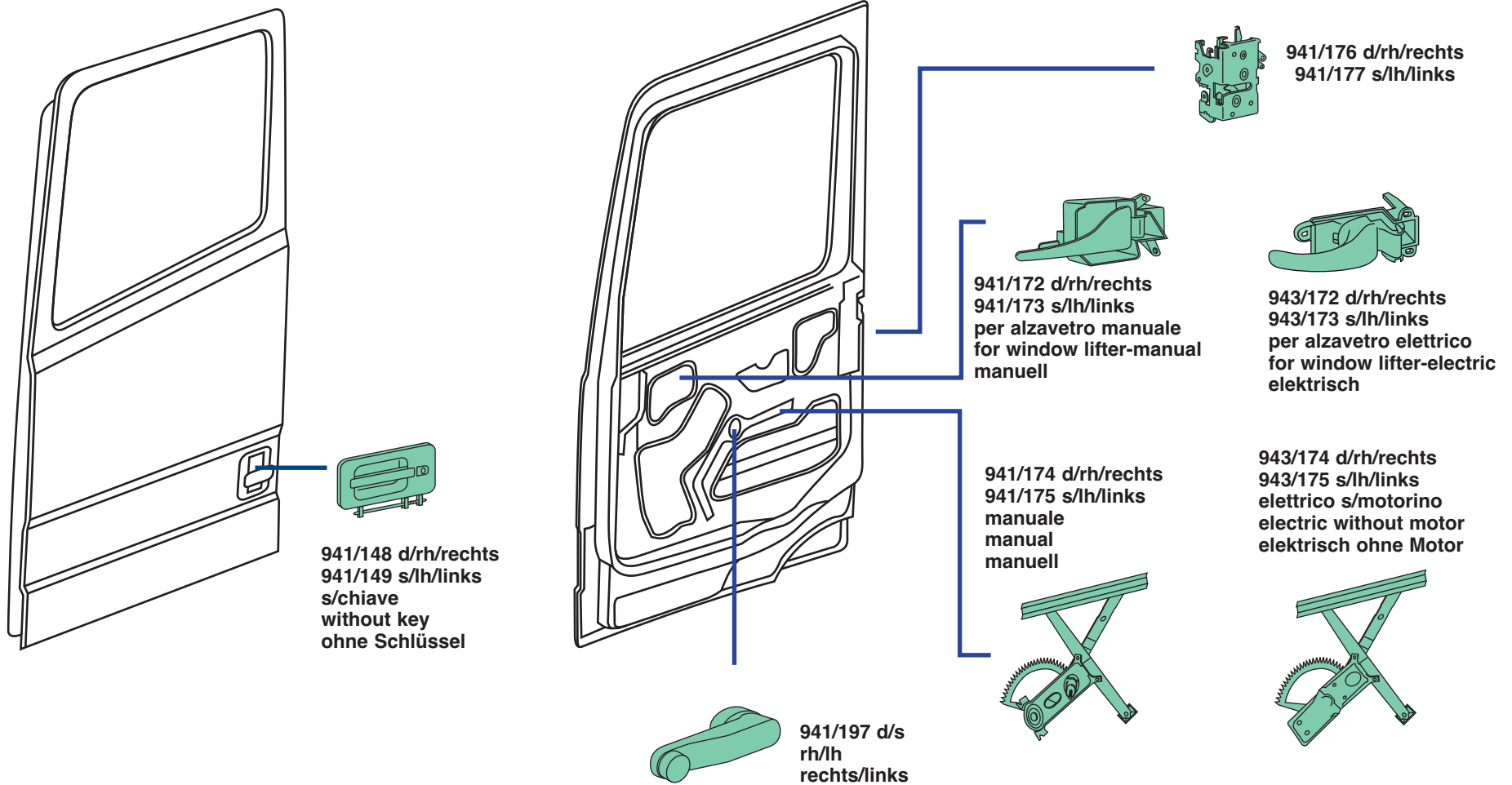

MERCEDES-BENZ ACTROS 2
 seconda serie / second version / zweite Serie

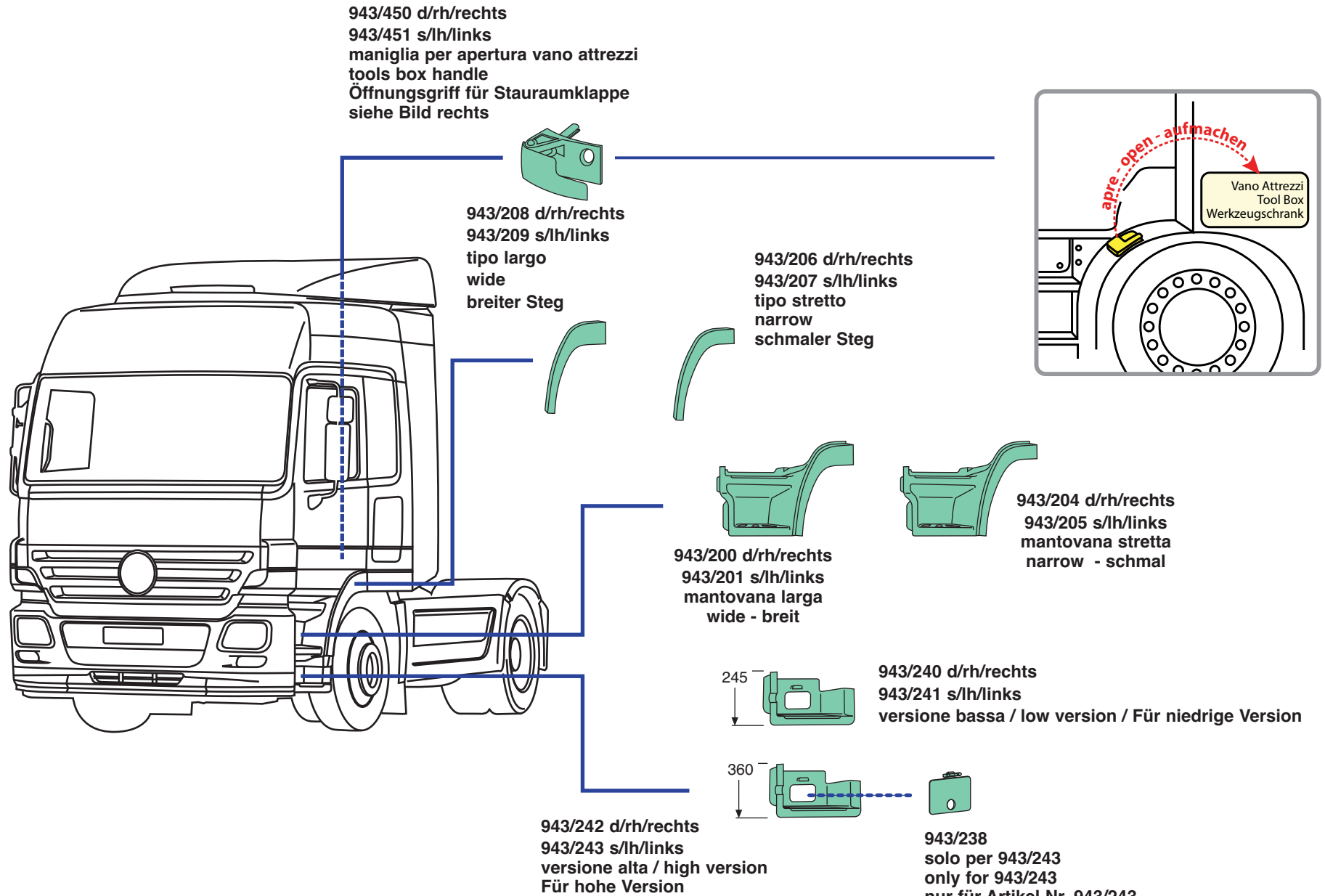

MERCEDES-BENZ ACTROS 2
seconda serie / second version / zweite Serie

98

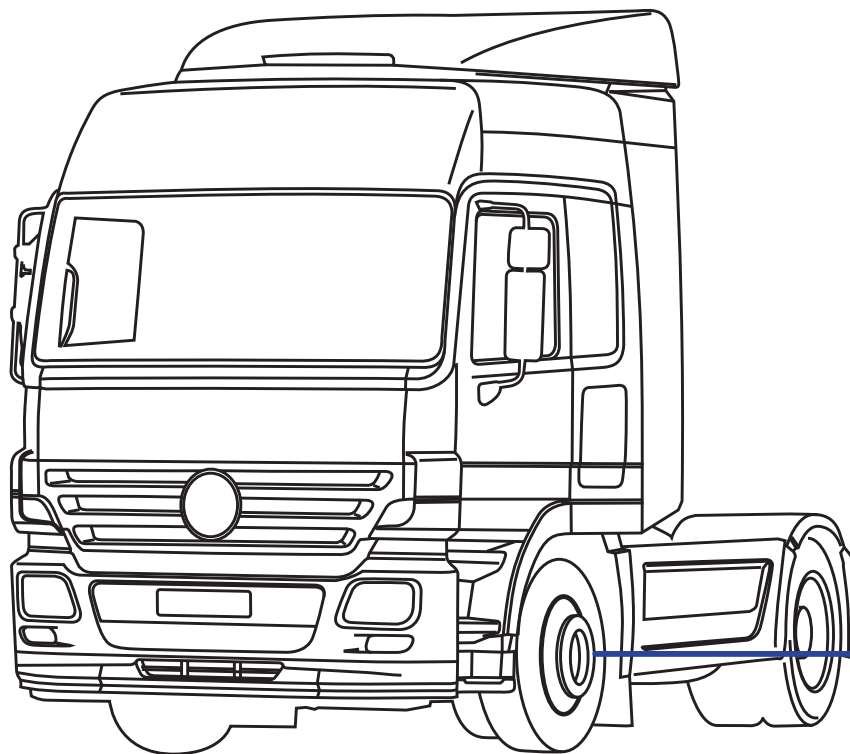

930/032
acciaio inox
stainless steel
Edelstahl

930/132
plastica - cromato
plastic - chrome
Kunststoff - verchromt



930/022 d/rh/rechts
930/023 s/lh/links
c/scritta
with written
mit Emblem

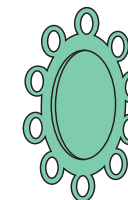

930/122 d/rh/rechts
930/123 s/lh/links
cerchi in lega
alloy wheels
Leichtmetallabdeckung

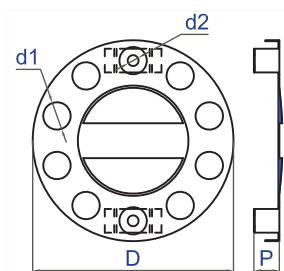

930/022 d/rh/rechts • 930/023 s/lh/lefts

D ø 425 mm	P 50 mm
d1 nr. 10	d1 ø 58 mm
d2 nr. 2	d2 ø 22,5 mm
Ventilata	si/yes/Ja
Ventilated/Belüftet	
Colore/	cromato/chrome/verchromt
Colours/Farbe	
Materiale/Material	acciaio inox e plastica stainless steel and plastic Edelstahl und Kunststoff
Kg	1,235

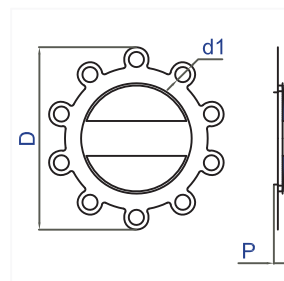

930/122 d/rh/rechts • 930/123 s/lh/lefts

D ø 387 mm	P 30 mm
d1 nr. 10	d1 ø 32 mm
Ventilata	si/yes/Ja
Ventilated/Belüftet	
Colore	cromato e nero/chrome and black verchromt und schwarz
Colours/Farbe	
Materiale/Material	acciaio inox e plastica stainless steel and plastic Edelstahl und Kunststoff
Kg	0,655

930/032 - Tappo copri Bullone • Bolt cover • Radmutterkappen

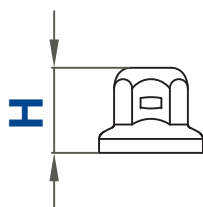

H	45 mm
Per bulloni ø / bolt ø	32 mm
Schlüsselweite ø	
Colore	cromato/chrome/verchromt
Colours/Farbe	
Materiale/Material	acciaio inox/stainless steel Edelstahl
Kg	0,025

930/132 - Tappo copri Bullone • Bolt cover • Radmutterkappen

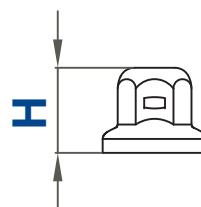

H	45 mm
Per bulloni ø / bolt ø	32 mm
Schlüsselweite ø	
Colore	cromato/chrome/verchromt
Colours/Farbe	
Materiale/Material	plastica/plastic/Kunststoff
Kg	0,014

MERCEDES-BENZ ACTROS 2 seconda serie / second version / zweite Serie

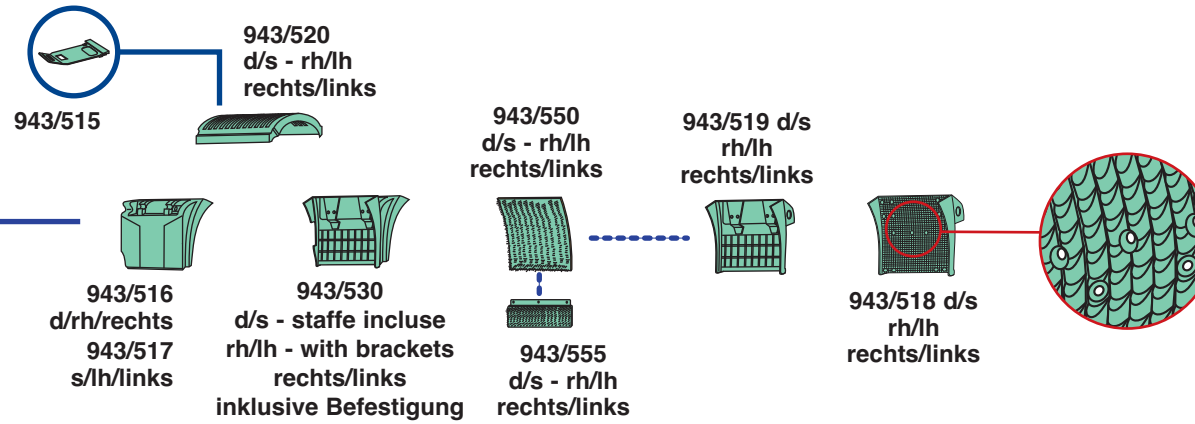

100

- A** con anti-spray/with anti-spray/mit Spritzschutz
- B** senza anti-spray/without anti-spray/ohne Spritzschutz
- C** con cinghietti/with stretcher/mit Befestigungsgummi
- D** senza cinghietti/without stretcher/ohne Befestigungsgummi

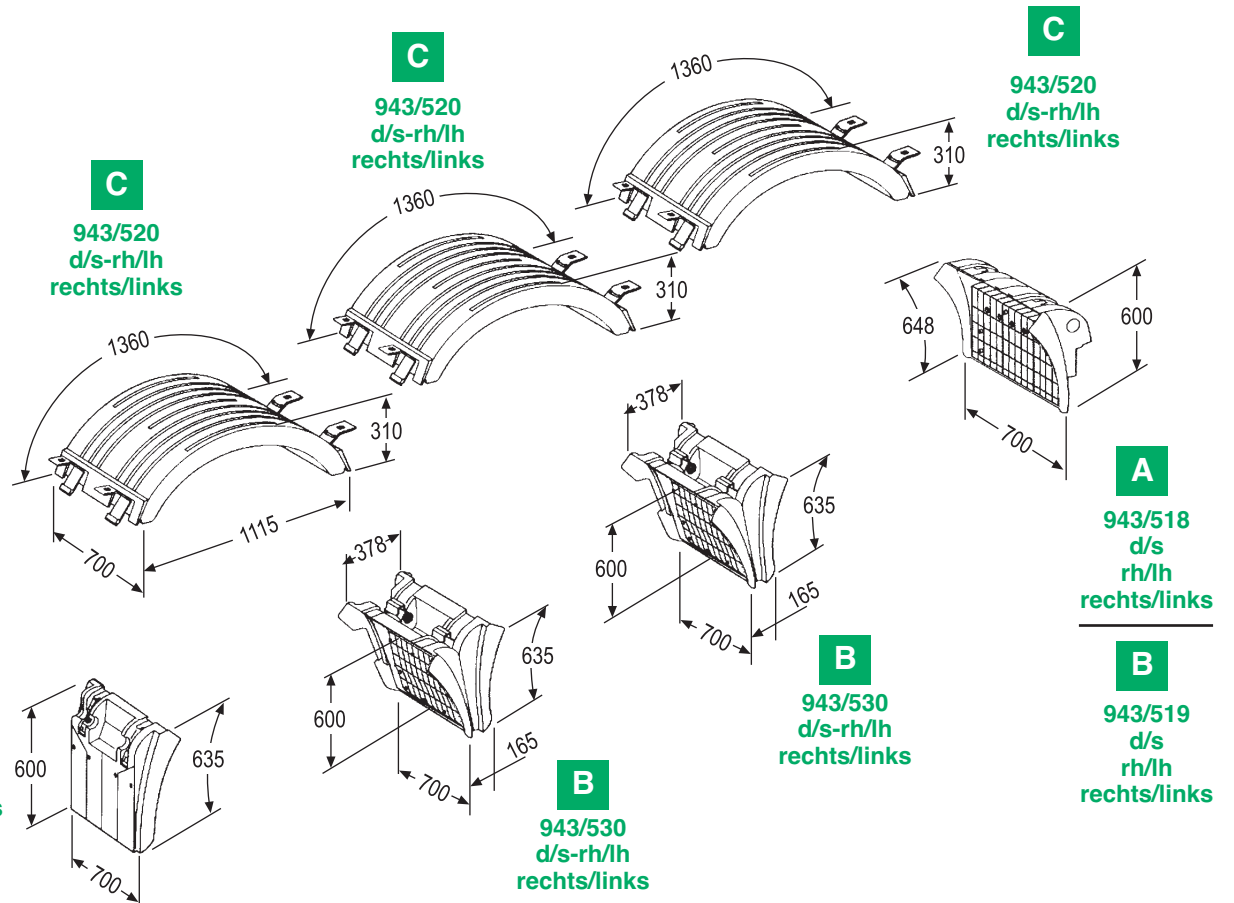

MERCEDES-BENZ ACTROS 2 seconda serie / second version / zweite Serie



943/515

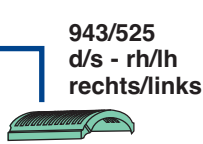

943/525
d/s - rh/lh
rechts/links



943/516
d/rh/rechts
943/517
s/lh/links



943/530
d/s - staffe include
rh/lh - with brackets
rechts/links
inklusive Befestigung

943/550
d/s - rh/lh
rechts/links



943/555
d/s - rh/lh
rechts/links



943/519
d/s - rh/lh
rechts/links

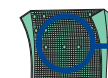

943/518
d/s - rh/lh
rechts/links

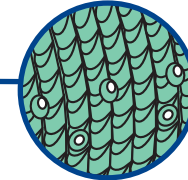

C

943/525
d/s-rh/lh
rechts/links

C

943/525
d/s-rh/lh
rechts/links

C

943/525
d/s-rh/lh
rechts/links

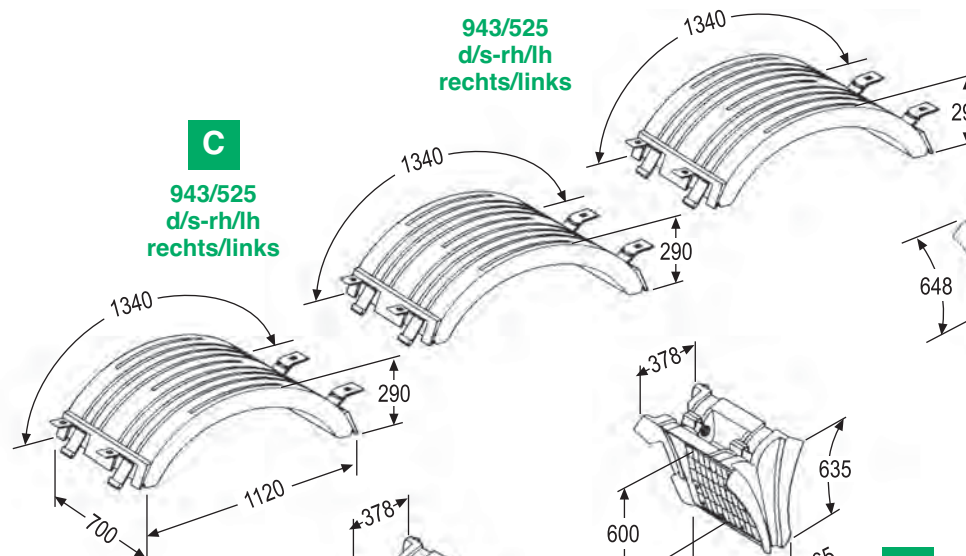

101

- A** con anti-spray/with anti-spray/mit Spritzschutz
- B** senza anti-spray/without anti-spray/ohne Spritzschutz
- C** con cinghietti/with stretcher/mit Befestigungsgummi
- D** senza cinghietti/without stretcher/ohne Befestigungsgummi

B

943/516 d/rh/rechts
943/517 s/lh/links

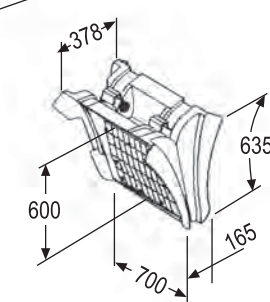
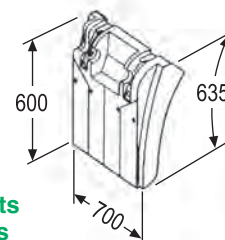

B

943/530
d/s-rh/lh
rechts/links

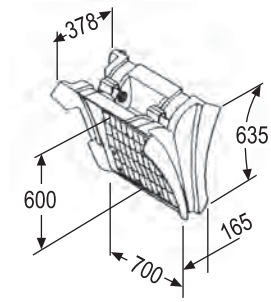

B

943/530
d/s-rh/lh
rechts/links

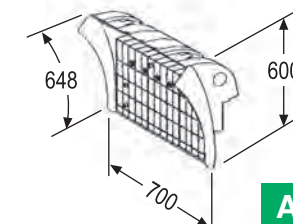

A

943/518
d/s
rh/lh
rechts/links

B

943/519
d/s
rh/lh
rechts/links

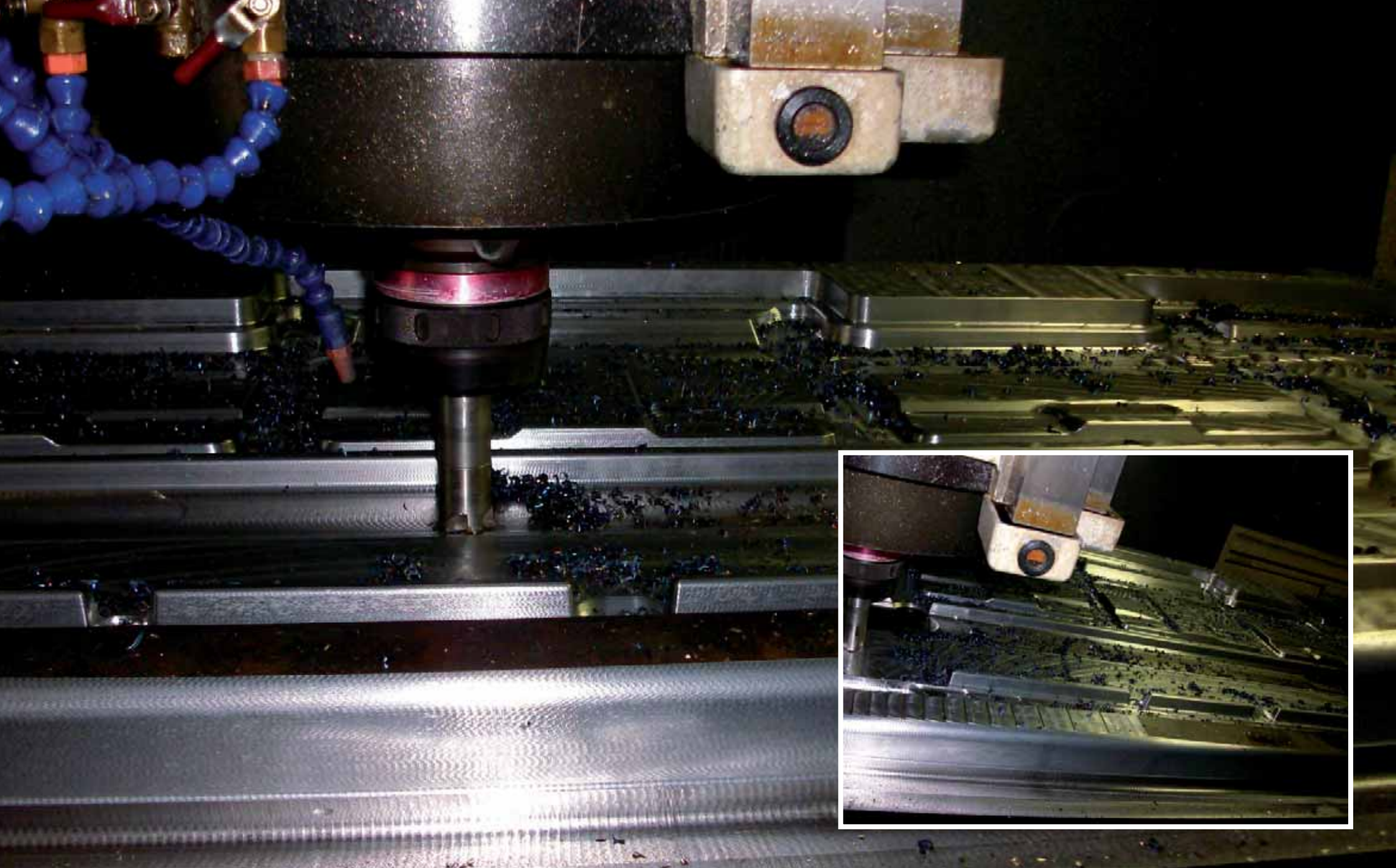

- ▲ IT Una fresatrice a controllo numerico (cnc) in lavorazione su uno stampo per paraurti
- UK Numerical control milling machine working on a mold for bumper
- DE Fräsbearbeitung einer Stahlform für die Stossstangenherstellung

MERCEDES

MERCEDES-BENZ ACTROS 2 MEGA SPACE



103



- ▲ IT Pressa per lo stampaggio ad iniezione
- UK Injection molding press
- DE Injektionspresse



943/ 72



943/ 92
c/presa d'aria
with air intake
mit Luftausschnitt

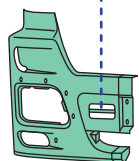

943/100

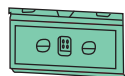

943/ 73



943/ 93
c/presa d'aria
with air intake
mit Luftausschnitt

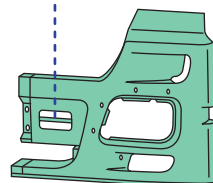

943/100

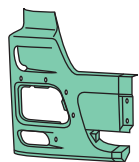
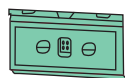

943/ 94

s/presa d'aria - c/foro fendinebbia
con boccole filettate per protezione fano
without air intake - with fog lamp hole
threaded bushing for headlamp protection
ohne Luftausschnitt
mit Nebelscheinwerferausschnitt
mit Gewindebuschsen für Scheinwerferschutz

943/ 95

s/presa d'aria - c/foro fendinebbia
con boccole filettate per protezione fano
without air intake - with fog lamp hole
threaded bushing for headlamp protection
ohne Luftausschnitt
mit Nebelscheinwerferausschnitt
mit Gewindebuschsen für Scheinwerferschutz

943/ 70

s/presa d'aria - c/foro fendinebbia
senza boccole filettate per protezione fano
without air intake - with fog lamp hole
threaded bushing for headlamp protection
ohne Luftausschnitt
mit Nebelscheinwerferausschnitt
ohne Gewindebuschsen für Scheinwerferschutz

943/ 71

s/presa d'aria - c/foro fendinebbia
senza boccole filettate per protezione fano
without air intake - with fog lamp hole
threaded bushing for headlamp protection
ohne Luftausschnitt
mit Nebelscheinwerferausschnitt
ohne Gewindebuschsen für Scheinwerferschutz

106

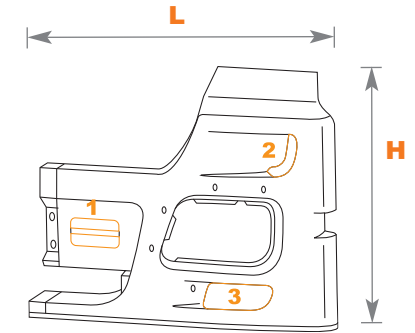

Legenda:
Key:
Legende:

1. Foro presa aria
Air intake
Luftausschnitt

2. Foro presa aria
Air intake
Luftausschnitt

3. Foro faro fendinebbia
Fog lamp hole
Nebelscheinwerferausschnitt

Codice Covind	Covind References	Covind Art. Nr.	Codice Originale	O.E. References	Vergleichs-Nr.	1	2	3	L	H	Peso	Weight	Gewicht	Colore	Color	Farbe	Materiale	Material	Material
943/ 70	d/rh/rechts		9438803973			x	✓	✓	1005 mm	885 mm	7,600 kg.			grigio/grey/grau			SMC		
943/ 71	s/lh/links		9438803873			x	✓	✓	1005 mm	885 mm	7,600 kg.			grigio/grey/grau			SMC		

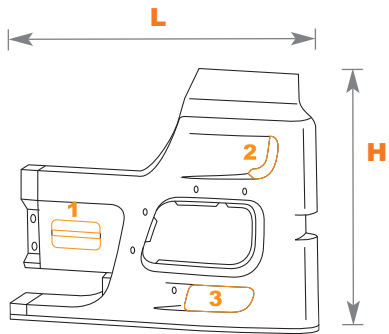

Legenda:
Key:
Legende:

1. Foro presa aria
Air intake
Luftausschnitt

2. Foro presa aria
Air intake
Luftausschnitt

3. Foro faro fendinebbia
Fog lamp hole
Nebelscheinwerferausschnitt



107

Codice Covind	Covind References	Covind Art. Nr.	Codice Originale	O.E. References	Vergleichs-Nr.	1	2	3	L	H	Peso	Weight	Gewicht	Colore	Color	Farbe	Materiale	Material	Material
943/ 92	d/rh/rechts		9438800104 - 9438804573			✓	✓	✓	1005 mm	885 mm	7,500			grigio/grey/grau			SMC		
943/ 93	s/lh/links		9438800004 - 9438804473			✓	✓	✓	1005 mm	885 mm	7,500			grigio/grey/grau			SMC		

108

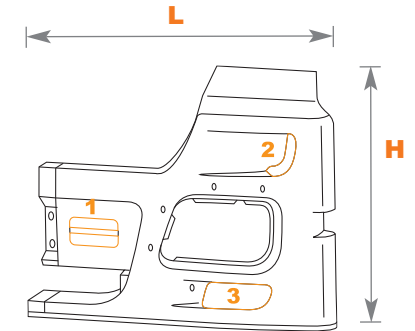

Legenda:
Key:
Legende:

- 1. Foro presa aria
Air intake
Luftausschnitt
- 2. Foro presa aria
Air intake
Luftausschnitt
- 3. Foro faro fendinebbia
Fog lamp hole
Nebelscheinwerferausschnitt

Codice Covind	Covind References	Covind Art. Nr.	Codice Originale	O.E. References	Vergleichs-Nr.	1	2	3	L	H	Peso	Weight	Gewicht	Colore	Color	Farbe	Materiale	Material	Material
943/ 94	d/rh/rechts		9438807470 - 9438809870			x	✓	✓	1005 mm	885 mm	7,600 kg.			grigio/grey/grau			SMC		
943/ 95	s/lh/links		9438807570			x	✓	✓	1005 mm	885 mm	7,600 kg.			grigio/grey/grau			SMC		

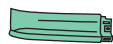
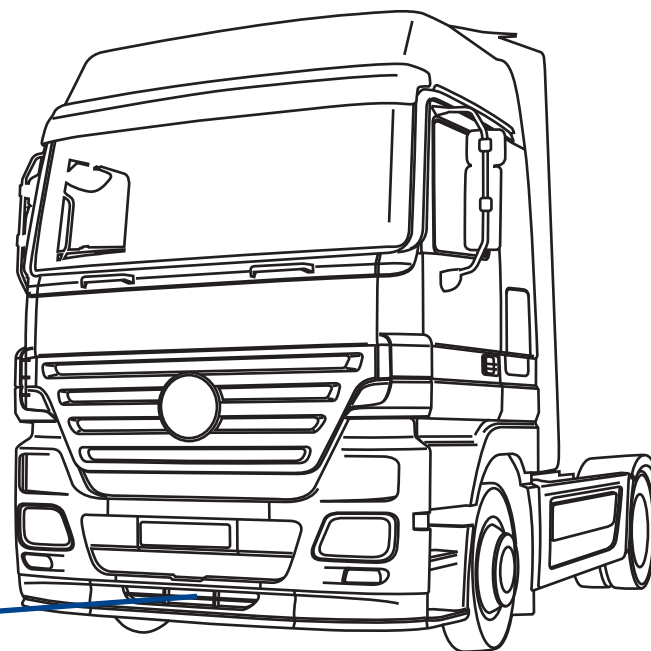

943/ 84
basso - low - niedrig

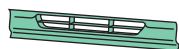

943/ 80
basso - low - niedrig



943/ 85
basso - low - niedrig



160



943/ 76
alto - high - hoch



943/ 75
alto - high - hoch



943/ 77
alto - high - hoch



220

110

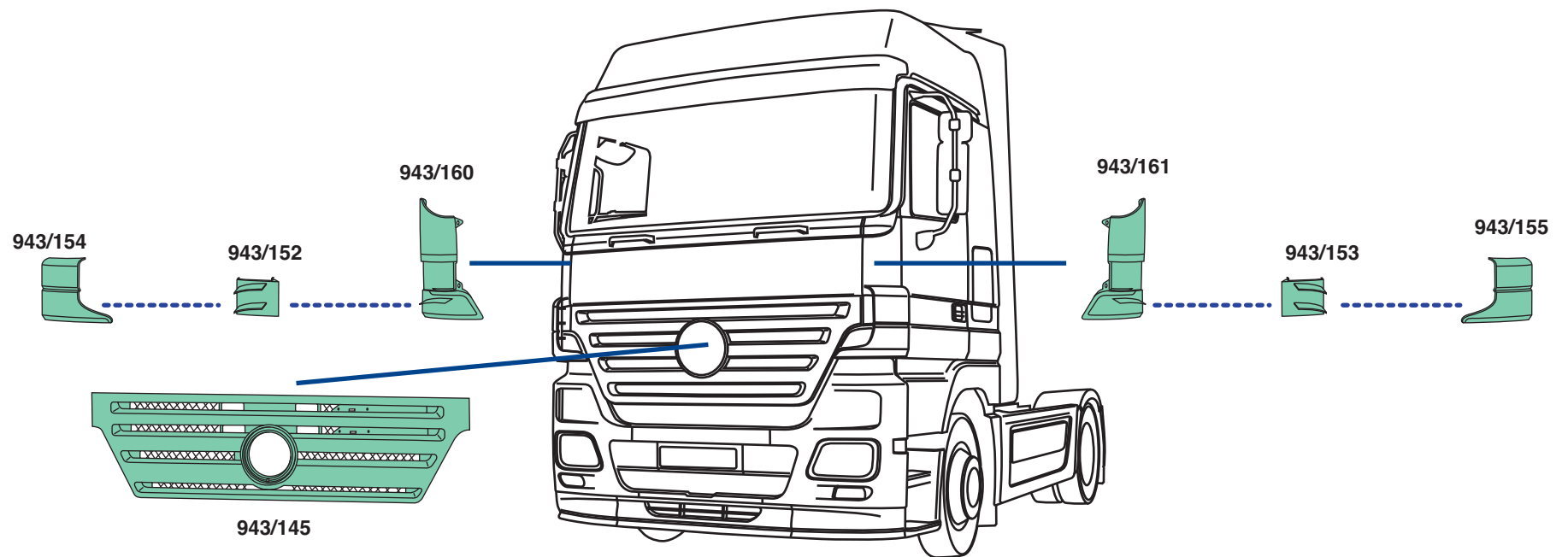

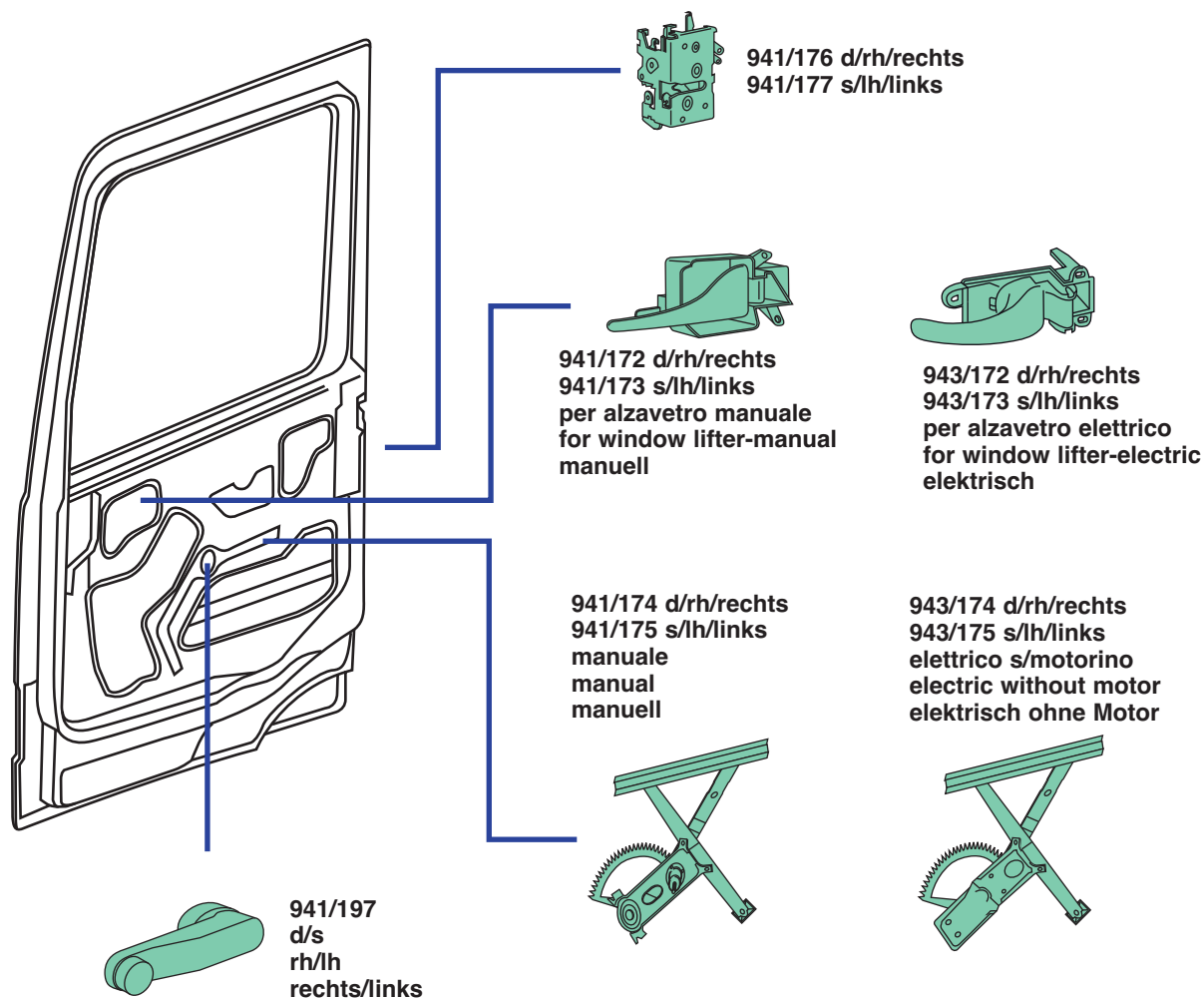

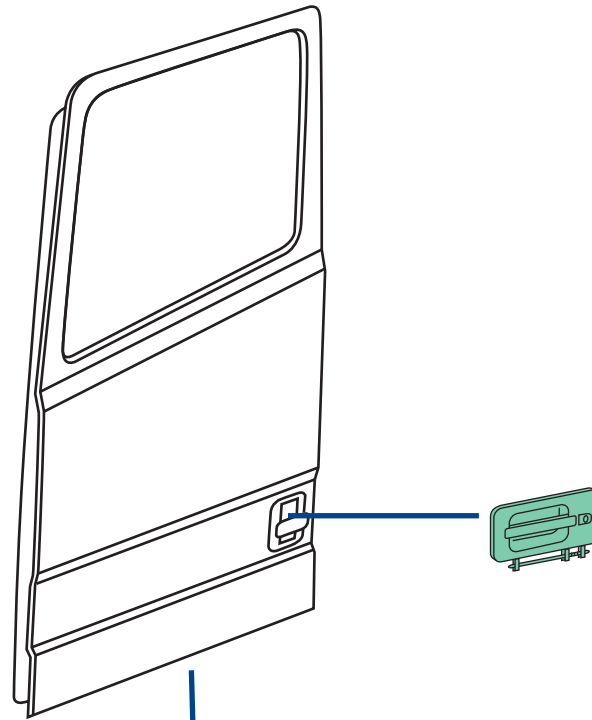

941/148 d/rh/rechts
941/149 s/lh/links
s/chiave
without key
ohne Schlüssel

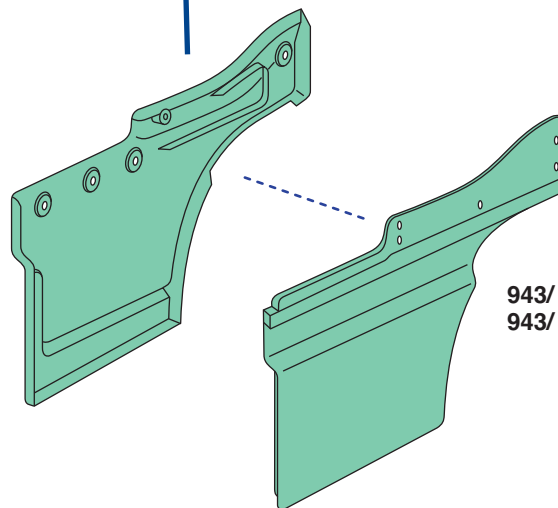

943/ 6 d/rh/rechts
943/ 7 s/lh/links

943/ 4 d/rh/rechts
943/ 5 s/lh/links

MERCEDES-BENZ ACTROS 2 MEGA SPACE

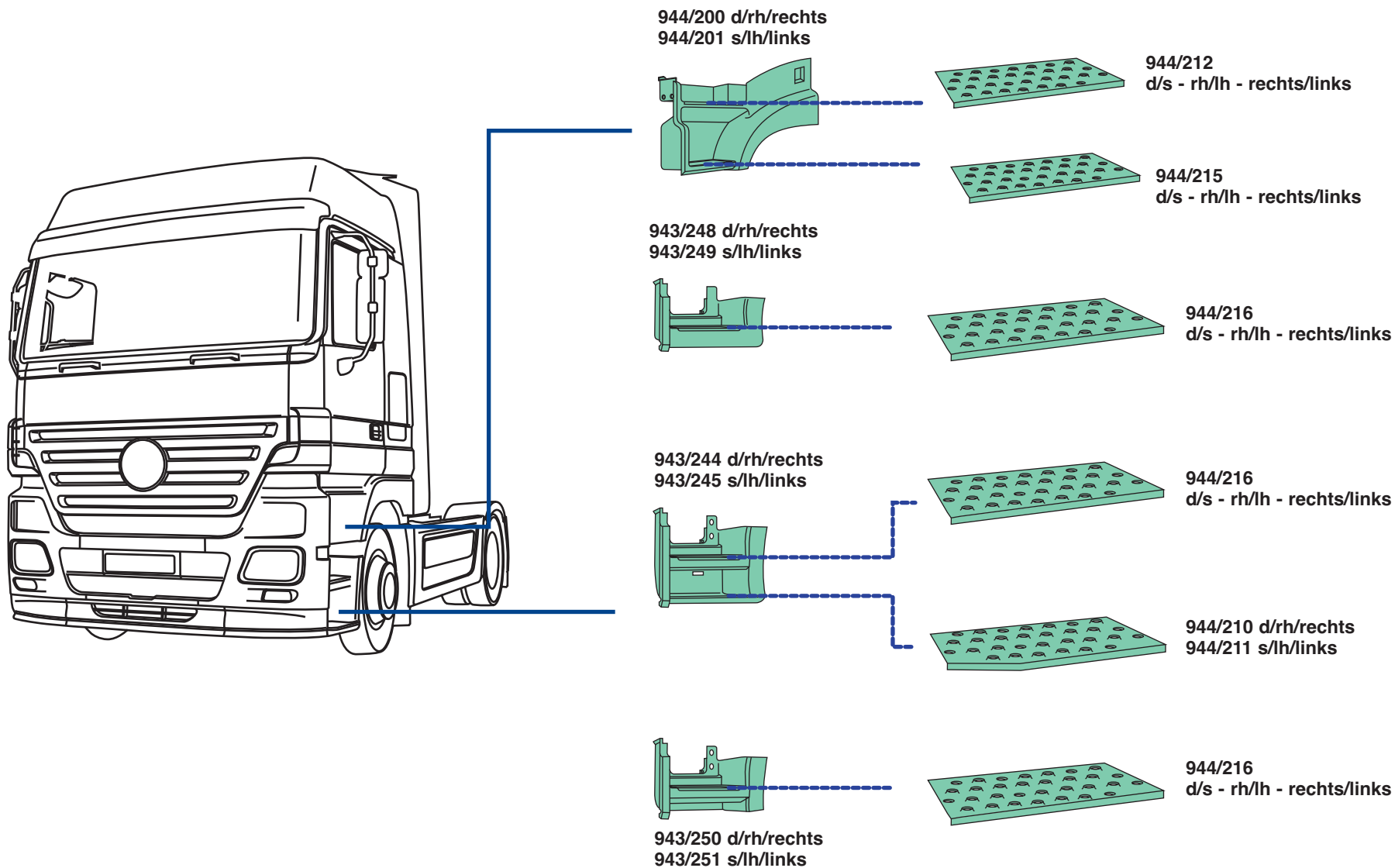

MERCEDES-BENZ ACTROS 2 MEGA SPACE

114

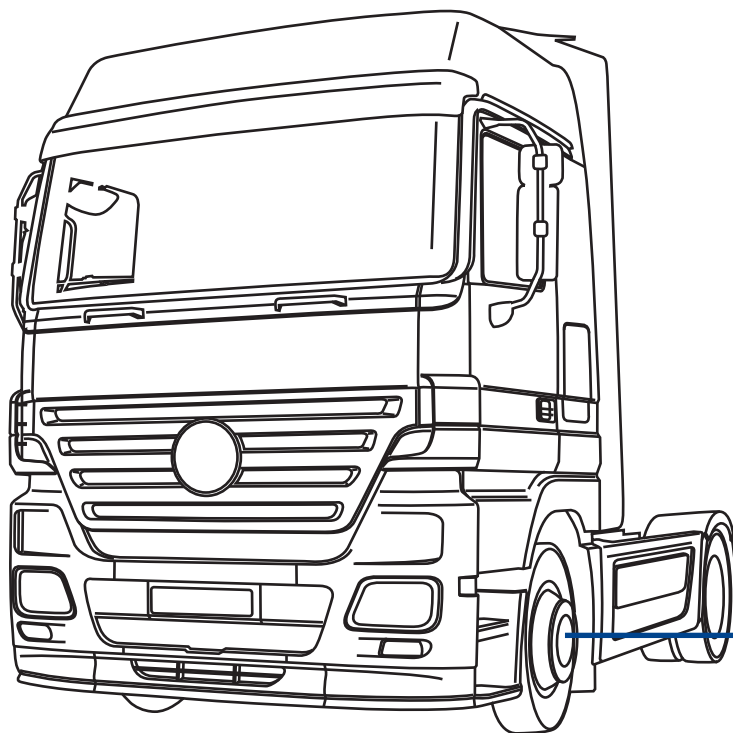

930/032
acciaio inox
stainless steel
Edelstahl

930/132
plastica - cromato
plastic - chrome
Kunststoff - verchromt



930/022 d/rh/rechts
930/023 s/lh/links
c/scritta
with written
mit Emblem

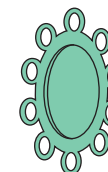

930/122 d/rh/rechts
930/123 s/lh/links
cerchi in lega
alloy wheels
Leichtmetallabdeckung

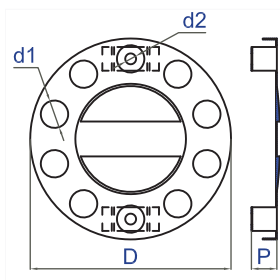

930/022 d/rh/rechts · 930/023 s/lh/links

D \varnothing 425 mm	P 50 mm
d1 nr. 10	d1 \varnothing 58 mm
d2 nr. 2	d2 \varnothing 22,5 mm
Ventilata	si/yes/Ja
Ventilated/Belüftet	
Colore/	cromato/chrome/verchromt
Colours/Farbe	
Materiale/Material	acciaio inox e plastica stainless steel and plastic Edelstahl und Kunststoff
Kg	1,235

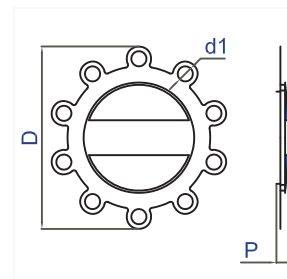

930/122 d/rh/rechts · 930/123 s/lh/links

D \varnothing 387 mm	P 30 mm
d1 nr. 10	d1 \varnothing 32 mm
Ventilata	si/yes/Ja
Ventilated/Belüftet	
Colore	cromato e nero/chrome and black
Colours/Farbe	verchromt und schwarz
Materiale/Material	acciaio inox e plastica stainless steel and plastic Edelstahl und Kunststoff
Kg	0,655

930/032 - Tappo copri Bullone · Bolt cover · Radmutterkappen

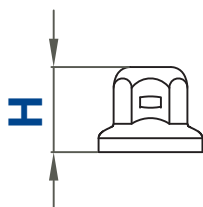

H	45 mm
Per bulloni \varnothing / bolt \varnothing	32 mm
Schlüsselweite \varnothing	
Colore	cromato/chrome/verchromt
Colours/Farbe	
Materiale/Material	acciaio inox/stainless steel Edelstahl
Kg	0,025

930/132 - Tappo copri Bullone · Bolt cover · Radmutterkappen

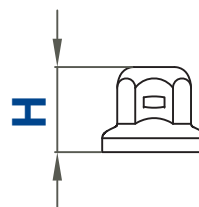

H	45 mm
Per bulloni \varnothing / bolt \varnothing	32 mm
Schlüsselweite \varnothing	
Colore	cromato/chrome/verchromt
Colours/Farbe	
Materiale/Material	plastica/plastic/Kunststoff
Kg	0,014

MERCEDES·BENZ ACTROS 2 MEGA SPACE

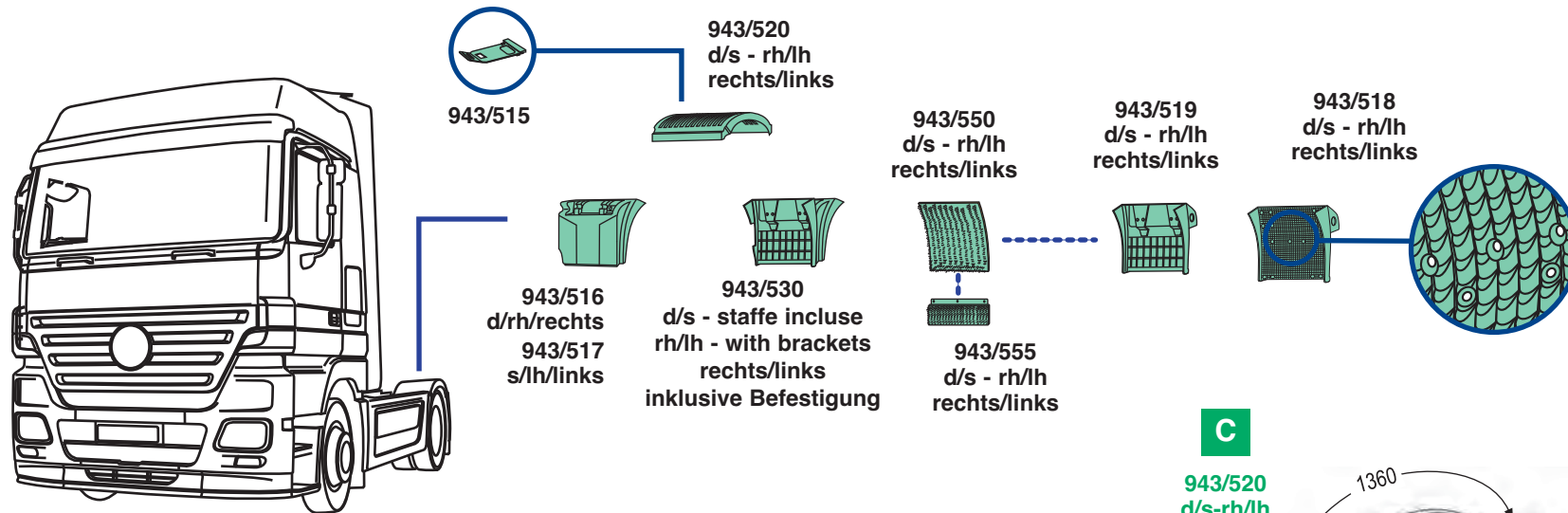

116

- A** con anti-spray/with anti-spray/mit Spritzschutz
- B** senza anti-spray/without anti-spray/ohne Spritzschutz
- C** con cinghietti/with stretcher/mit Befestigungsgummi
- D** senza cinghietti/without stretcher/ohne Befestigungsgummi

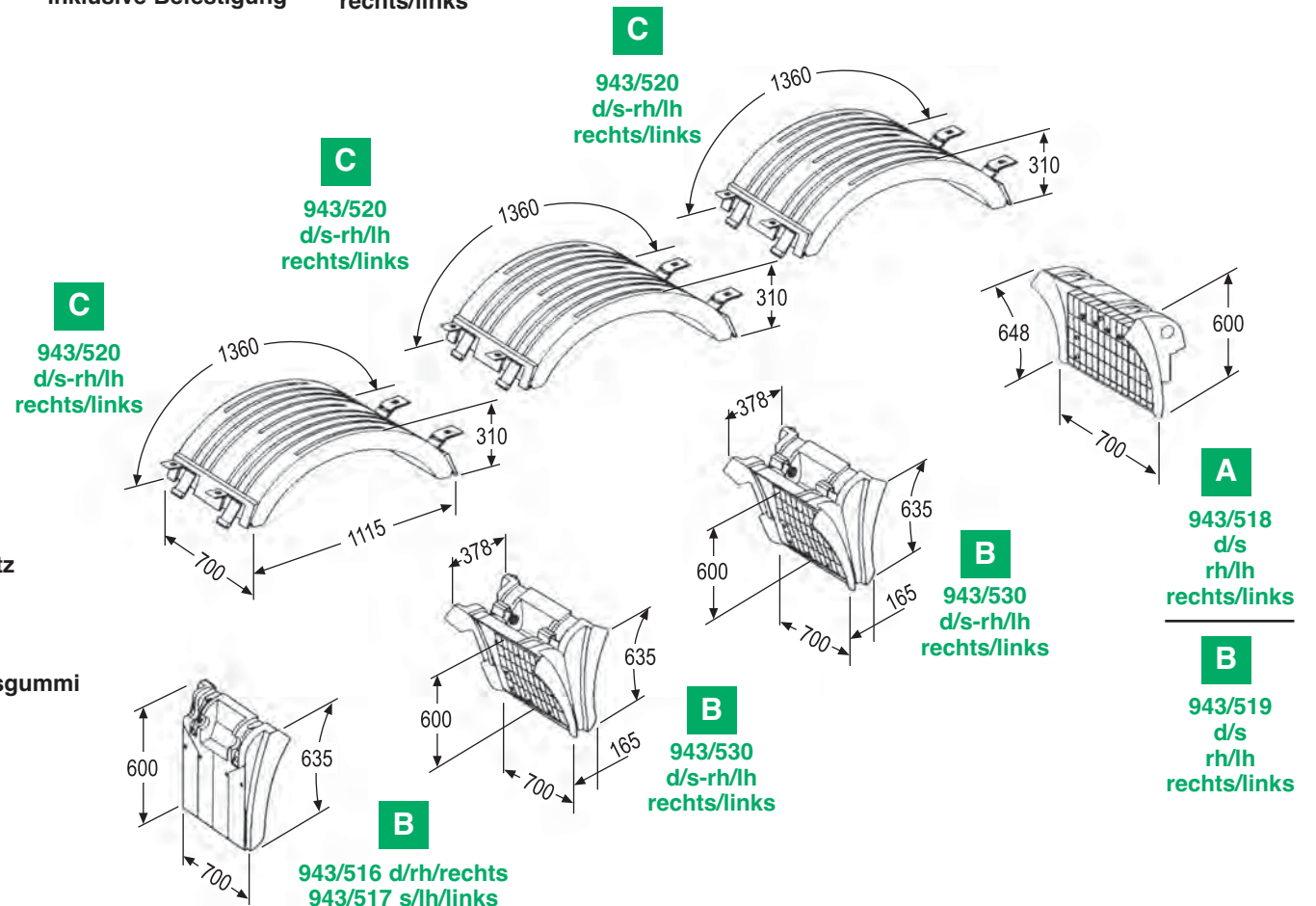

MERCEDES-BENZ ACTROS 2 MEGA SPACE

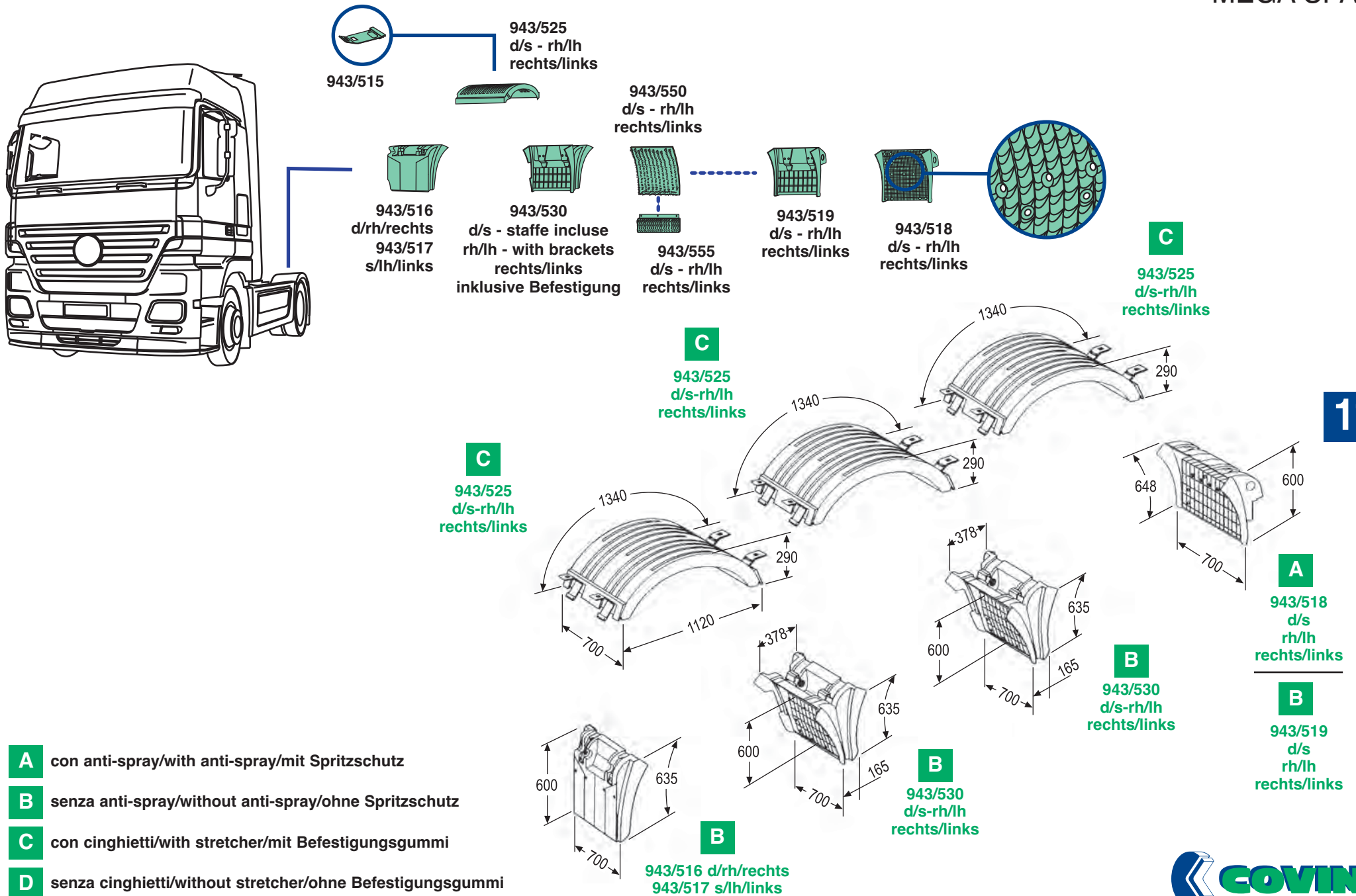

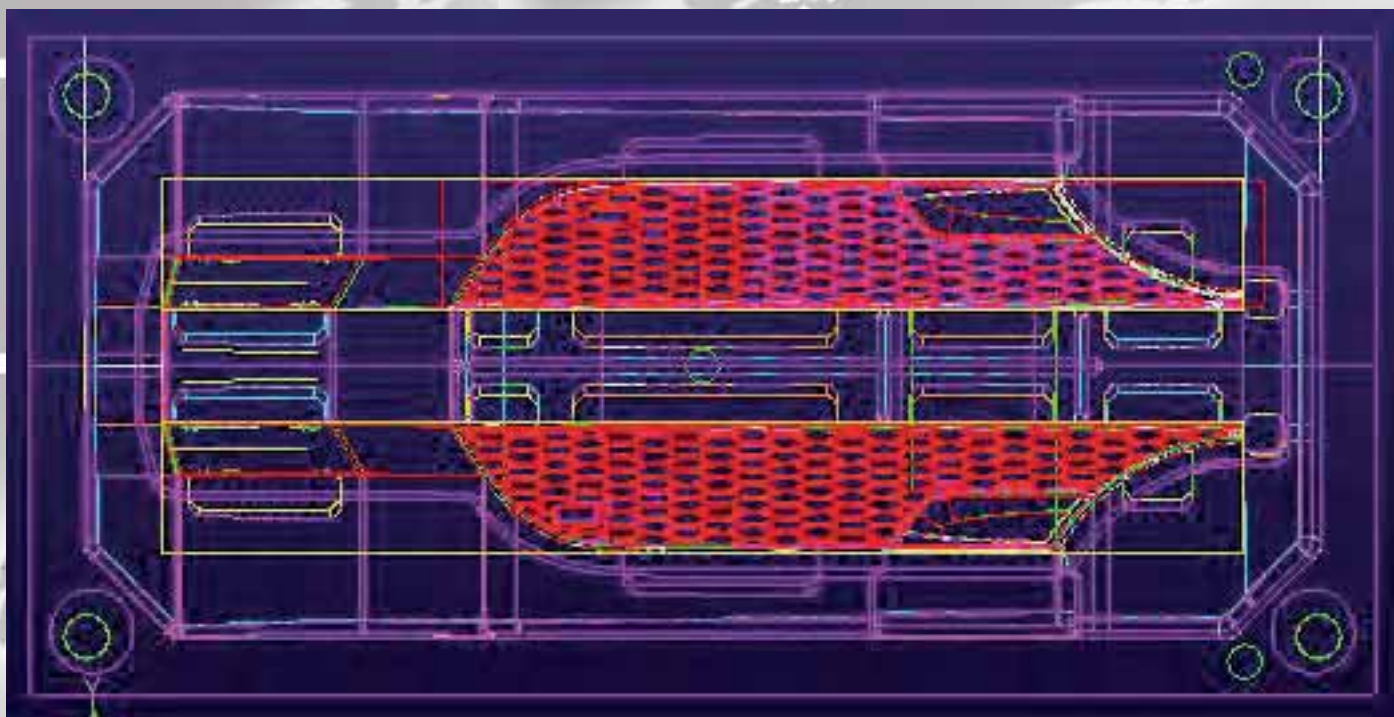

- ▲ IT Progetto in 3D dello stampo ad iniezione per la produzione di griglie
- UK 3-D Project for the mould to be used for the production of grille
- DE 3D-Projekt der Stahlform für die Herstellung von Grill

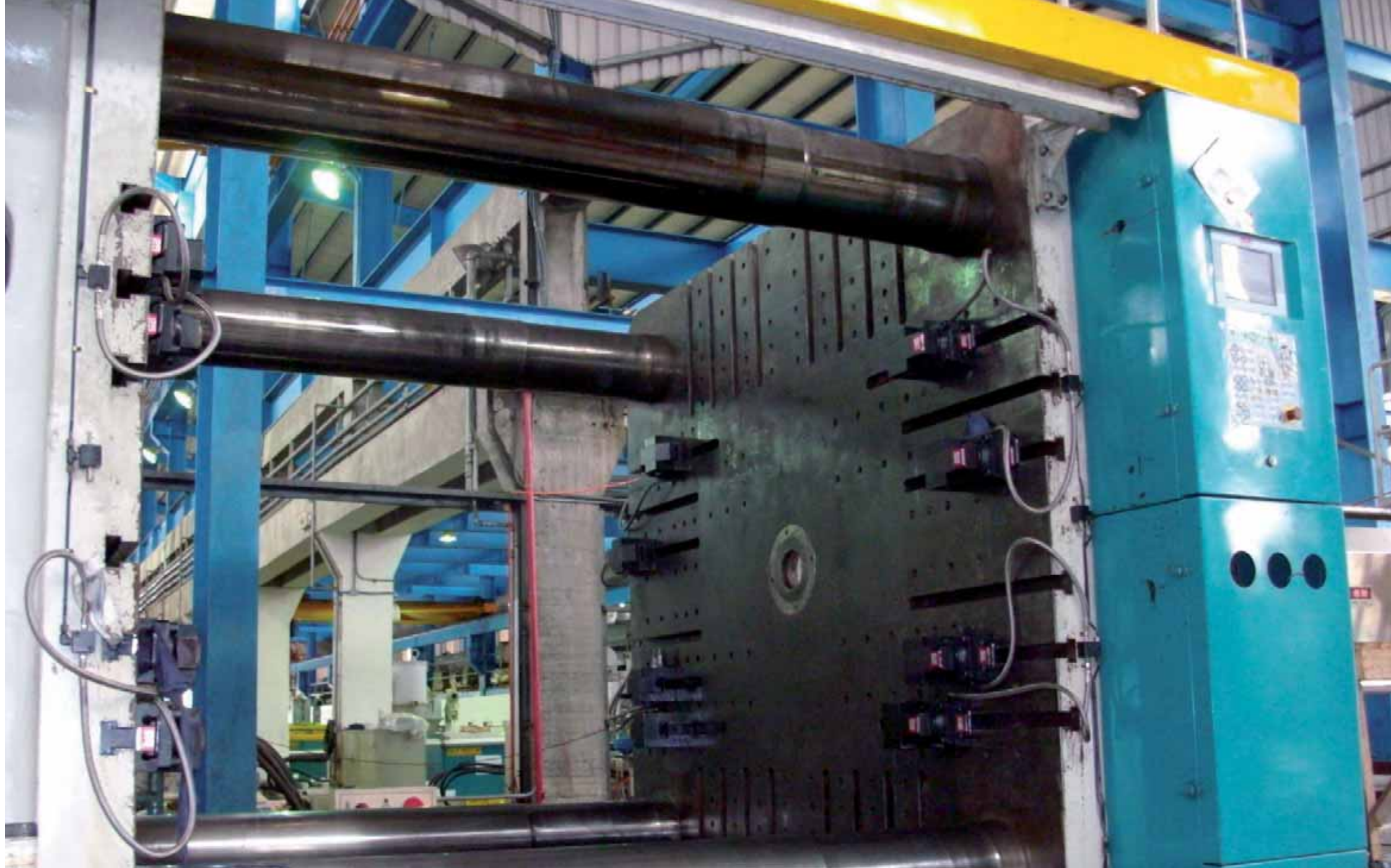

▲ IT Dettaglio delle colonne di scorrimento di una pressa orizzontale (4.000 t)

UK Details of the sliding columns of a horizontal press (4.000 t)

DE Details der horizontalen 4.000 to. Presse



- ▲ IT Pressa ad iniezione (4.000 t) per la produzione di componenti di grosse dimensioni
- UK injection press (4.000 t) for the production of large size components
- DE Spritzgießmaschine (4.000 to.) für die Herstellung von großen Werkstücken

MERCEDES

MERCEDES-BENZ ACTROS 1
prima serie / first version / erste Serie

121



MERCEDES·BENZ ACTROS 1
prima serie / first version / erste Serie

941/ 90

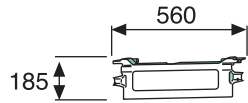

122

940/941
coppia protezione faro
pair headlamp protection
Paar Scheinwerferschutz
>2002

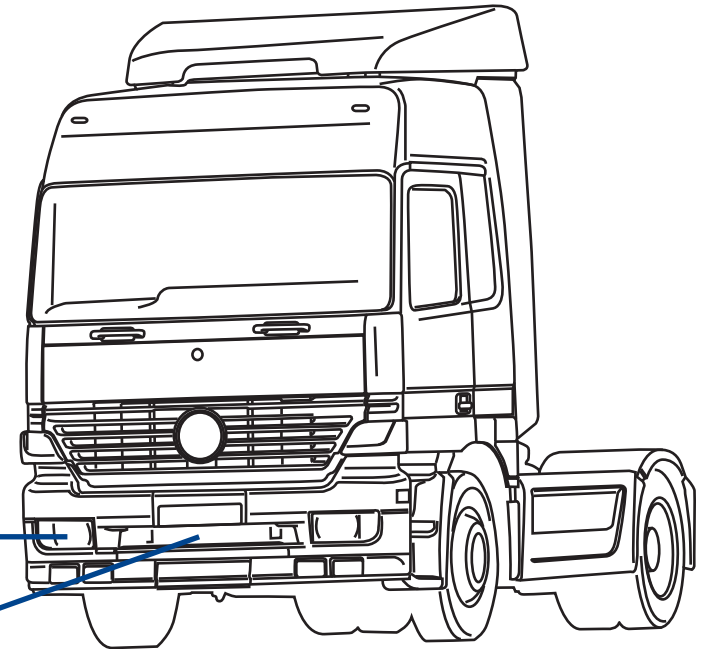

941/124

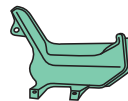

941/120



941/125

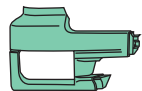

941/ 92
s/foro
without hole
ohne Lochausschnitt



941/ 94
c/foro
with hole
mit Lochausschnitt

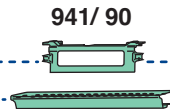

941/ 96

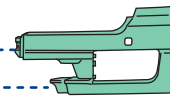

941/ 95
c/foro
with hole
mit Lochausschnitt

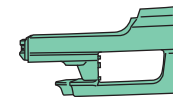

941/ 93
s/foro
without hole
ohne Lochausschnitt

anche versione cava-cantiere
even in the version yard & quarry
auch für Baustellenfahrzeuge

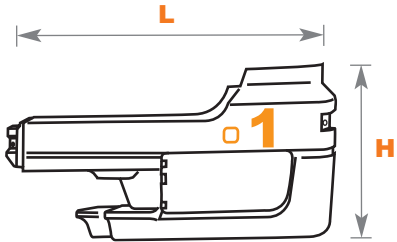

Legenda:
Key:
Legende:

1. Foro tergi faro
Headlight wipers
Scheinwerferreinigungsanlage



123

Codice Covind	Covind References	Covind Art. Nr.	Codice Originale	O.E. References	Vergleichs-Nr.	1	L	H	Peso	Weight	Gewicht	Colore	Color	Farbe	Materiale	Material	Material
941/ 92	d/rh/rechts		9418801070			x	1000 mm	555 mm	5,300	kg.		grigio/grey/grau			SMC		
941/ 93	s/lh/links		9418800970			x	1000 mm	555 mm	5,300	kg.		grigio/grey/grau			SMC		

124

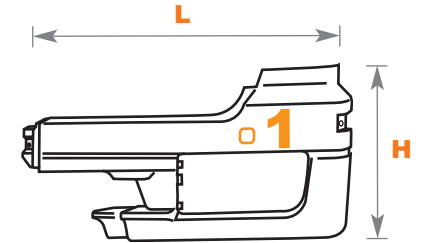

Legenda:
Key:
Legende:

1. Foro tergi faro
Headlight wipers
Scheinwerferreinigungsanlage

Codice Covind	Covind References	Covind Art. Nr.	Codice Originale	O.E. References	Vergleichs-Nr.	1	L	H	Peso	Weight	Gewicht	Colore	Color	Farbe	Materiale	Material	Material
941/ 94	d/rh/rechts		9418802470			✓	1000 mm	555 mm	5,300 kg.			grigio/grey/grau			SMC		
941/ 95	s/lh/links		9418802370			✓	1000 mm	555 mm	5,300 kg.			grigio/grey/grau			SMC		

(*) Versione Cava-Cantiere
Yard & Quarry version
Baustellenfahrzeug

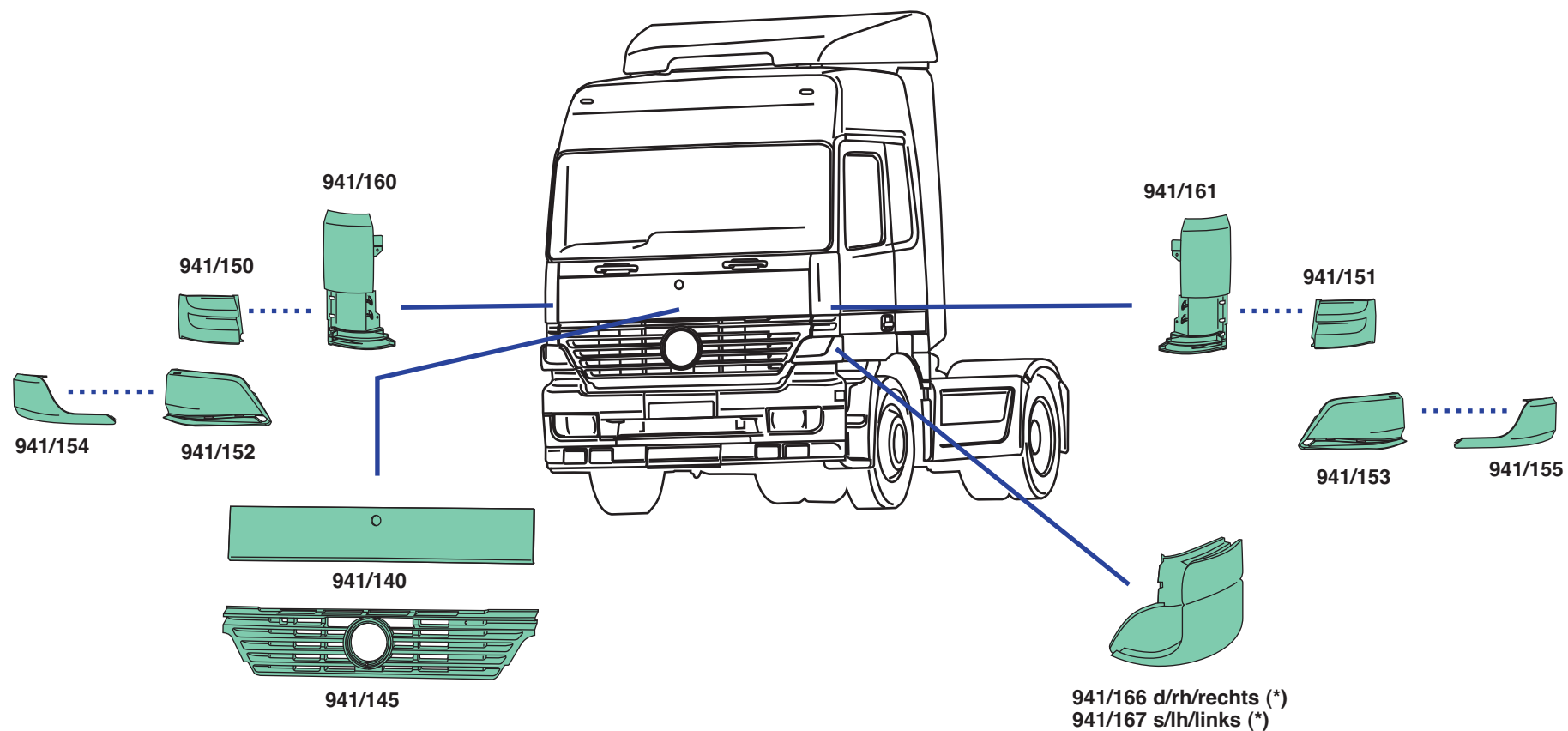

MERCEDES-BENZ ACTROS 1
prima serie / first version / erste Serie

126

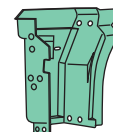
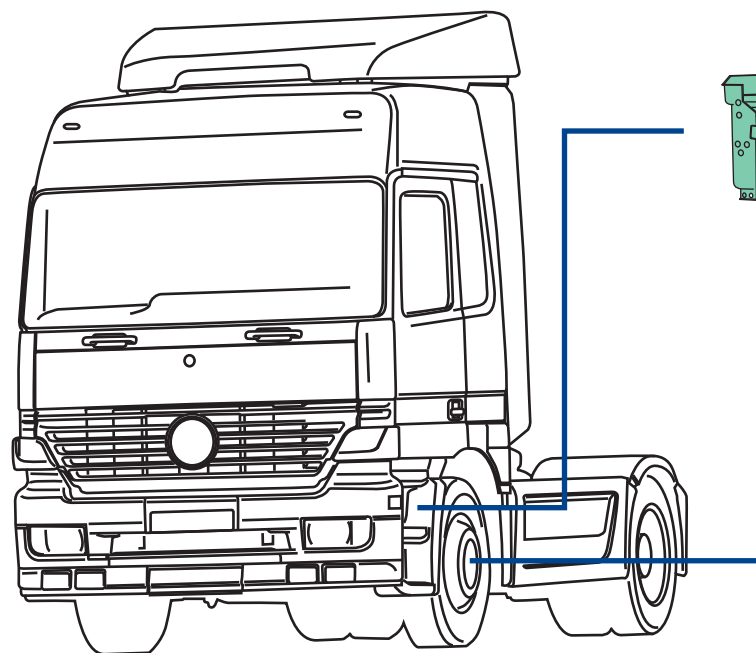

941/240 d/rh/rechts
941/241 s/lh/links

930/022 d/rh/rechts
930/023 s/lh/links
c/scritta
with written
mit Emblem



930/032
acciaio inox
stainless steel
Edelstahl

930/132
plastica - cromato
plastic - chrome
Kunststoff - verchromt



930/122 d/rh/rechts
930/123 s/lh/links
cerchi in lega
alloy wheels
Leichtmetallabdeckung

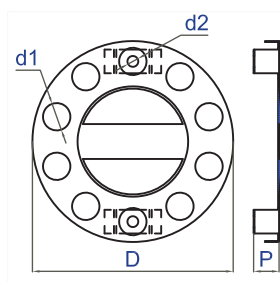

930/022 d/rh/rechts • 930/023 s/lh/links

D ø 425 mm	P 50 mm
d1 nr. 10	d1 ø 58 mm
d2 nr. 2	d2 ø 22,5 mm
Ventilata	si/yes/Ja
Ventilated/Belüftet	
Colore/	cromato/chrome/verchromt
Colours/Farbe	
Materiale/Material	acciaio inox e plastica stainless steel and plastic Edelstahl und Kunststoff
Kg	1,235

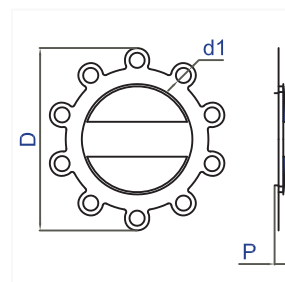

930/122 d/rh/rechts • 930/123 s/lh/links

D ø 387 mm	P 30 mm
d1 nr. 10	d1 ø 32 mm
Ventilata	si/yes/Ja
Ventilated/Belüftet	
Colore	cromato e nero/chrome and black
Colours/Farbe	verchromt und schwarz
Materiale/Material	acciaio inox e plastica stainless steel and plastic Edelstahl und Kunststoff
Kg	0,655

930/032 - Tappo copri Bullone • Bolt cover • Radmutterkappen

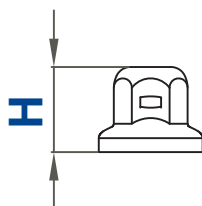

H	45 mm
Per bulloni ø / bolt ø	32 mm
Schlüsselweite ø	
Colore	cromato/chrome/verchromt
Colours/Farbe	
Materiale/Material	acciaio inox/stainless steel Edelstahl
Kg	0,025

930/132 - Tappo copri Bullone • Bolt cover • Radmutterkappen

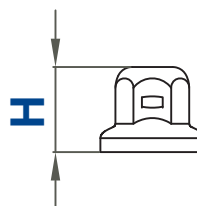

H	45 mm
Per bulloni ø / bolt ø	32 mm
Schlüsselweite ø	
Colore	cromato/chrome/verchromt
Colours/Farbe	
Materiale/Material	plastica/plastic/Kunststoff
Kg	0,014

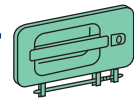
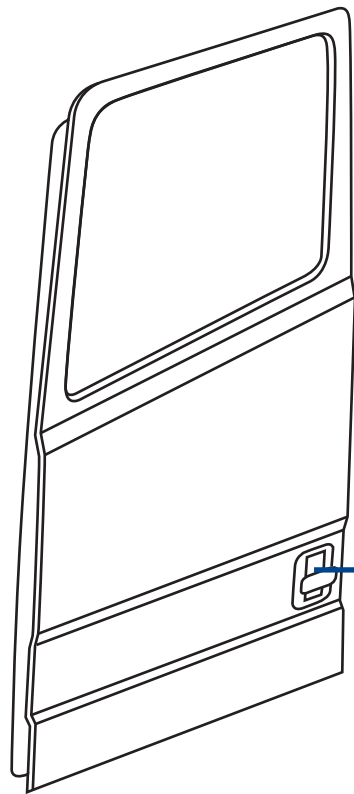

941/148 d/rh/rechts
941/149 s/lh/links
s/chiave
without key
ohne Schlüssel

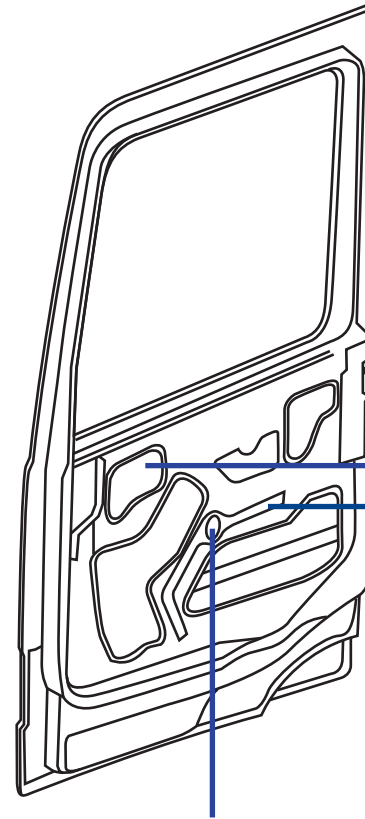

941/176 d/rh/rechts
941/177 s/lh/links

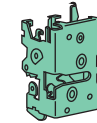

943/172 d/rh/rechts
943/173 s/lh/links
per alzatetro elettrico
for window lifter-electric
elektrisch

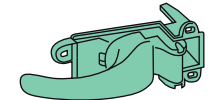

941/172 d/rh/rechts
941/173 s/lh/links
per alzatetro manuale
for window lifter-manual
manuell

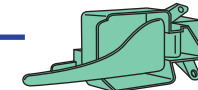

941/174 d/rh/rechts
941/175 s/lh/links
manuale
manual
manuell

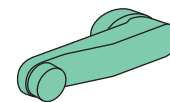
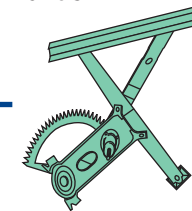

941/197
d/s
rh/lh
rechts/links

MERCEDES-BENZ ACTROS 1 prima serie / first version / erste Serie

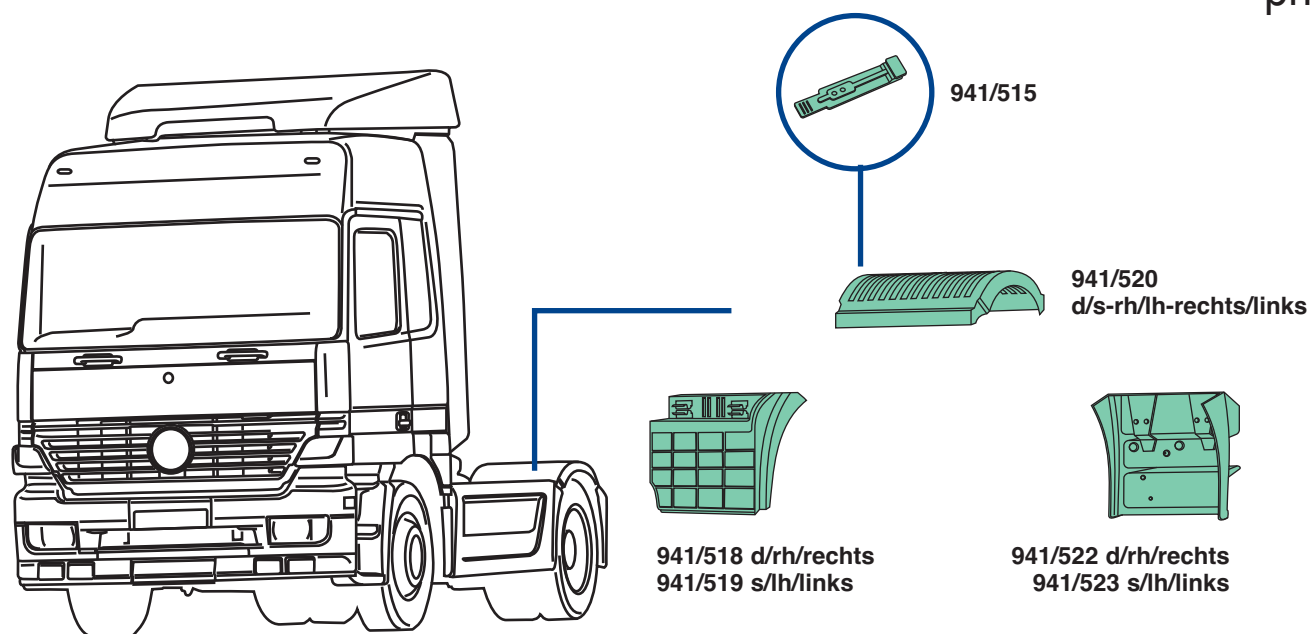

129

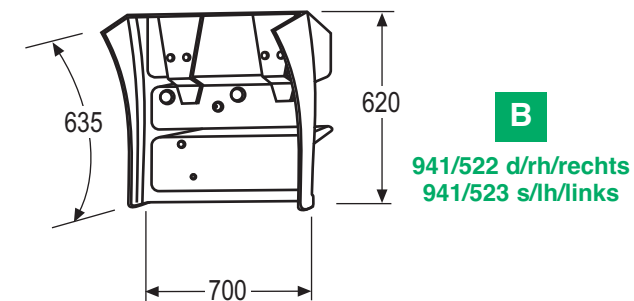
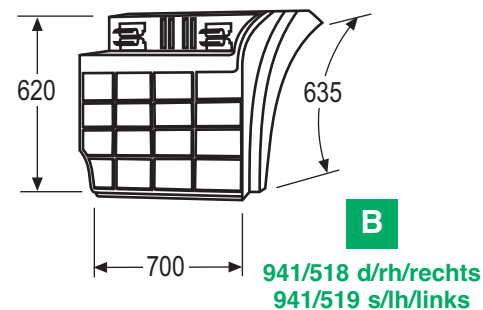
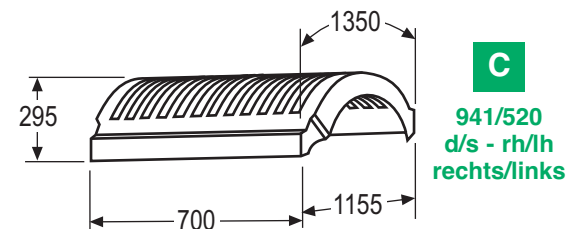

- A** con anti-spray/with anti-spray/mit Spritzschutz
- B** senza anti-spray/without anti-spray/ohne Spritzschutz
- C** con cinghietti/with stretcher/mit Befestigungsgummi
- D** senza cinghietti/without stretcher/ohne Befestigungsgummi

MERCEDES-BENZ ACTROS 1 prima serie / first version / erste Serie

130

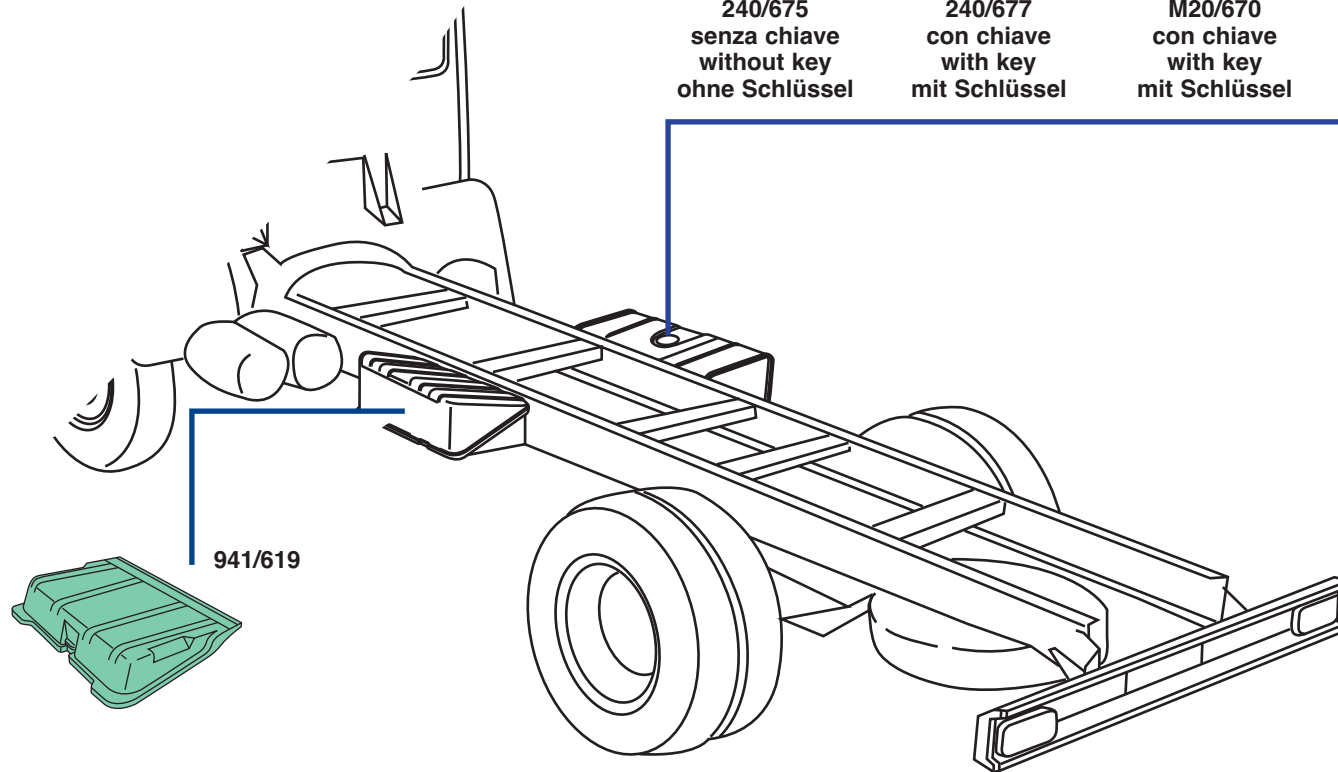

240/675
senza chiave
without key
ohne Schlüssel



240/677
con chiave
with key
mit Schlüssel



M20/670
con chiave
with key
mit Schlüssel



0FH/670
senza chiave
without key
ohne Schlüssel

240/675

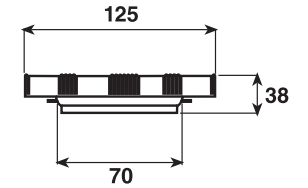

240/677

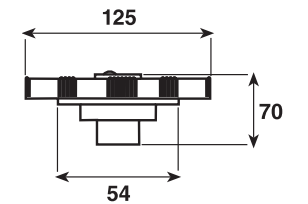

M20/670

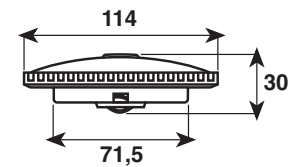

0FH/670

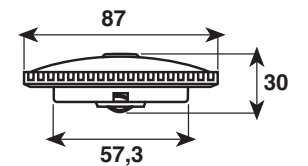

MERCEDES

MERCEDES-BENZ ACTROS 1
MEGA SPACE

131



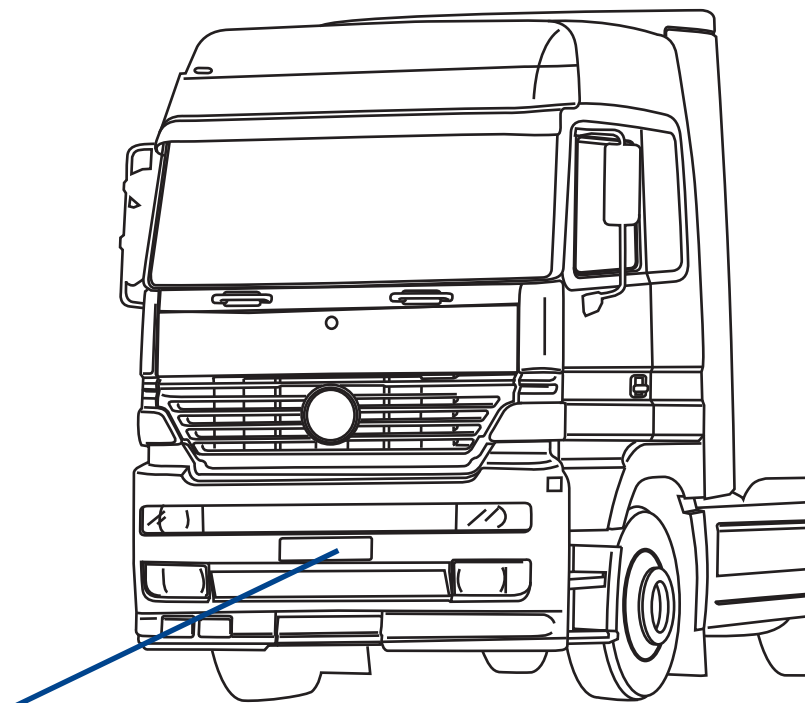
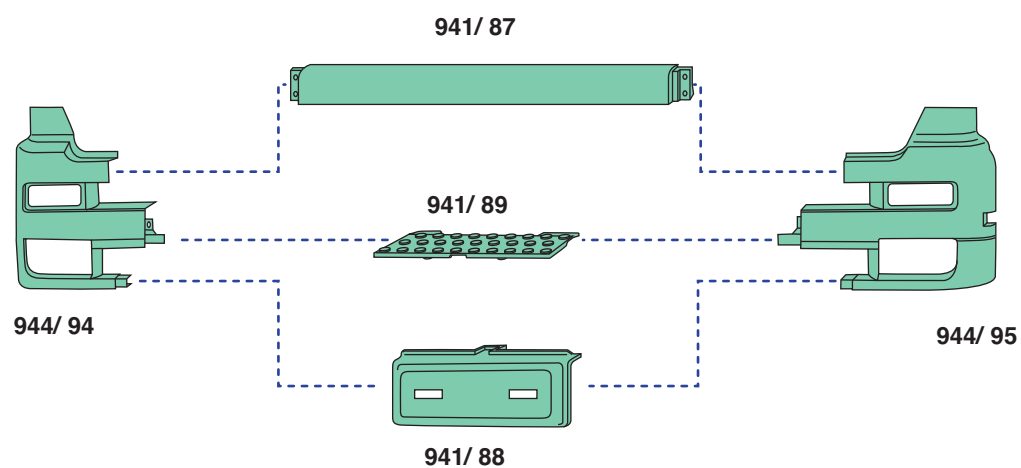

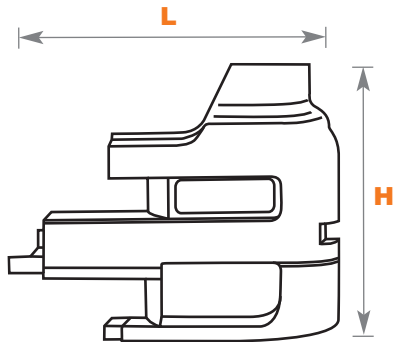

133

Codice Covind Covind References Covind Art. Nr.	Codice Originale O.E. References Vergleichs-Nr.	L	H	Peso Weight Gewicht	Colore Color Farbe	Materiale Material Material
944/ 94 d/rh/rechts	9418802870	1055 mm	875 mm	8,150 kg.	grigio/grey/grau	SMC
944/ 95 s/lh/links	9418802770	1055 mm	875 mm	8,150 kg.	grigio/grey/grau	SMC

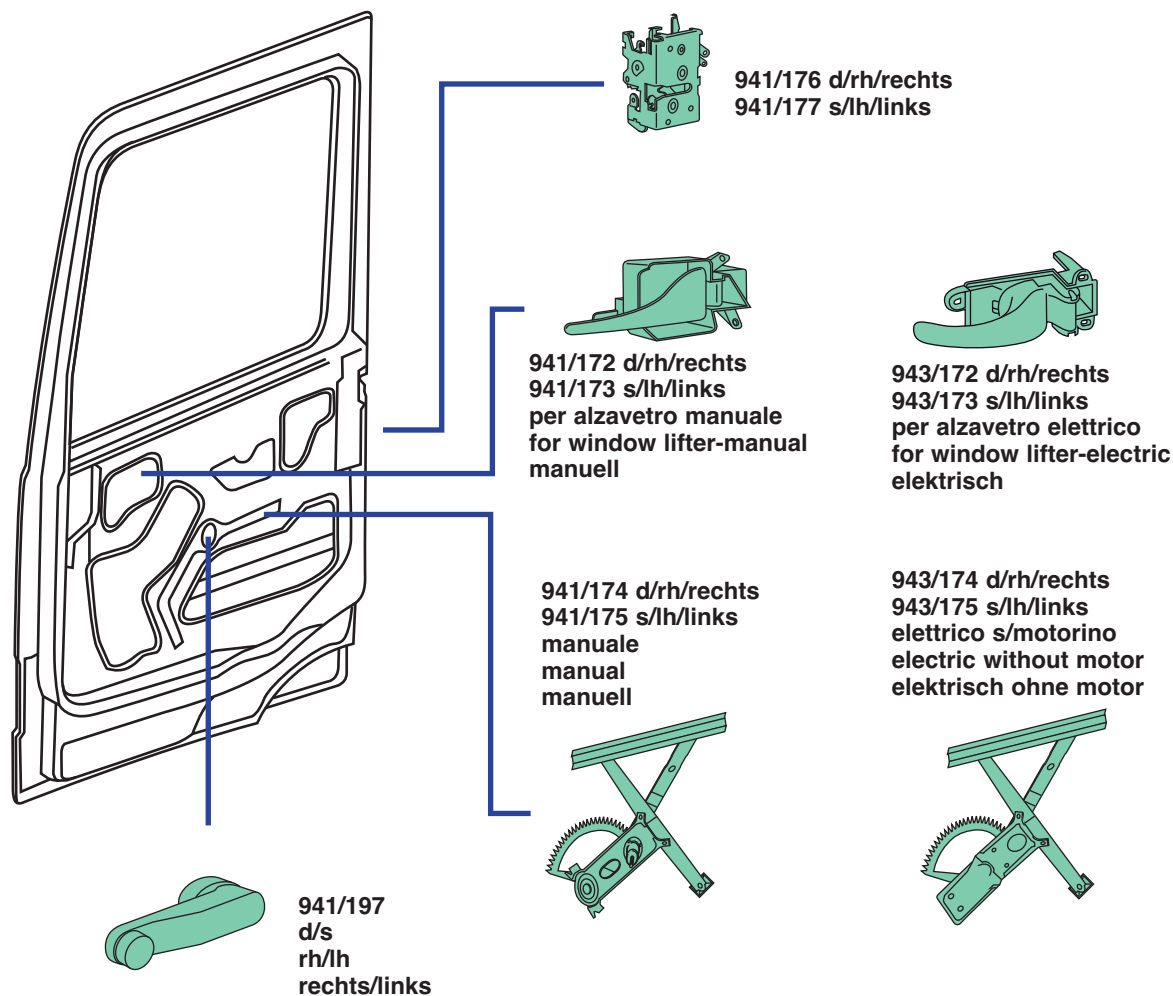

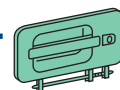
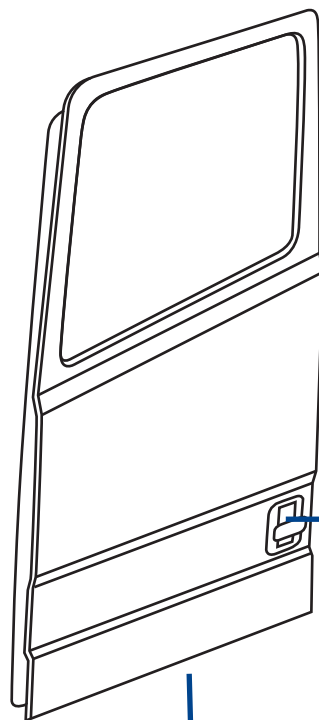

941/148 d/rh/rechts
941/149 s/lh/links
s/chiave
without key
ohne Schlüssel

943/ 6 d/rh/rechts
943/ 7 s/lh/links

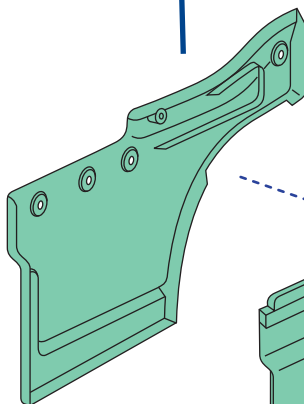

943/ 4 d/rh/rechts
943/ 5 s/lh/links

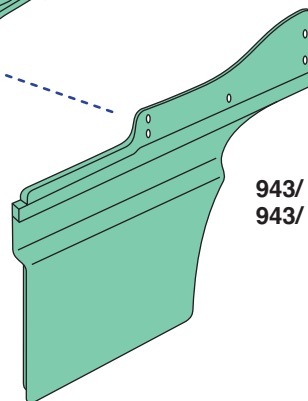

MERCEDES-BENZ ACTROS 1 MEGA SPACE

136

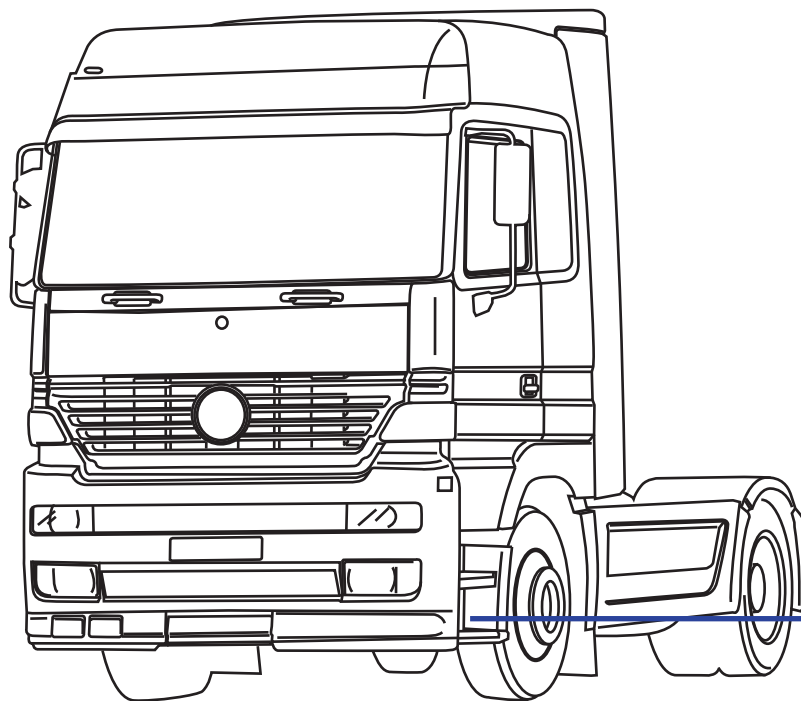

944/200 d/rh/rechts
944/201 s/lh/links

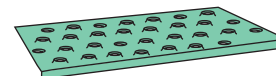
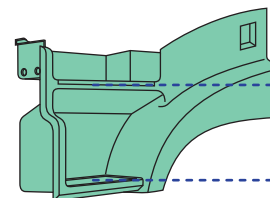

944/212
d/s - rh/lh - rechts/links

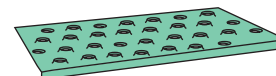

944/215
d/s - rh/lh - rechts/links

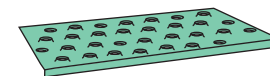
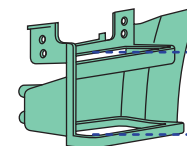

944/216
d/s - rh/lh - rechts/links

944/240 d/rh/rechts
944/241 s/lh/links

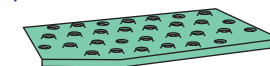

944/210 d/rh/rechts
944/211 s/lh/links

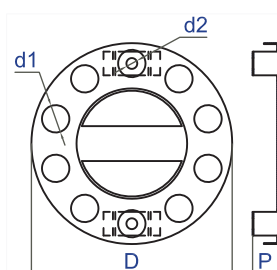

930/022 d/rh/rechts • 930/023 s/lh/linki

D ø 425 mm	P 50 mm
d1 nr. 10	d1 ø 58 mm
d2 nr. 2	d2 ø 22,5 mm
Ventilata	si/yes/Ja
Ventilated/Belüftet	
Colore/Colours/Farbe	cromato/chrome/verchromt
Materiale/Material	acciaio inox e plastica stainless steel and plastic Edelstahl und Kunststoff
Kg	1,235

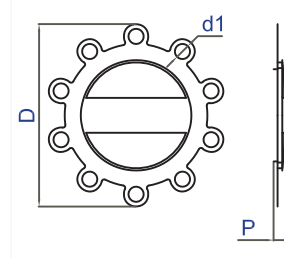

930/122 d/rh/rechts • 930/123 s/lh/linki

D ø 387 mm	P 30 mm
d1 nr. 10	d1 ø 32 mm
Ventilata	si/yes/Ja
Ventilated/Belüftet	
Colore/Colours/Farbe	cromato e nero/chrome and black verchromt und schwarz
Materiale/Material	acciaio inox e plastica stainless steel and plastic Edelstahl und Kunststoff
Kg	0,655

930/032 - Tappo copri Bullone • Bolt cover • Radmutterkappen

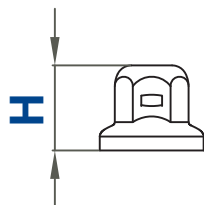

H	45 mm
Per bulloni ø / bolt ø	32 mm
Schlüsselweite ø	
Colore/Colours/Farbe	cromato/chrome/verchromt
Materiale/Material	acciaio inox/stainless steel Edelstahl
Kg	0,025

930/132 - Tappo copri Bullone • Bolt cover • Radmutterkappen

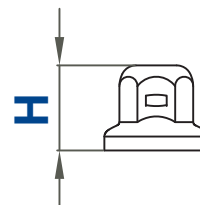

H	45 mm
Per bulloni ø / bolt ø	32 mm
Schlüsselweite ø	
Colore/Colours/Farbe	cromato/chrome/verchromt
Materiale/Material	plastica/plastic/Kunststoff
Kg	0,014

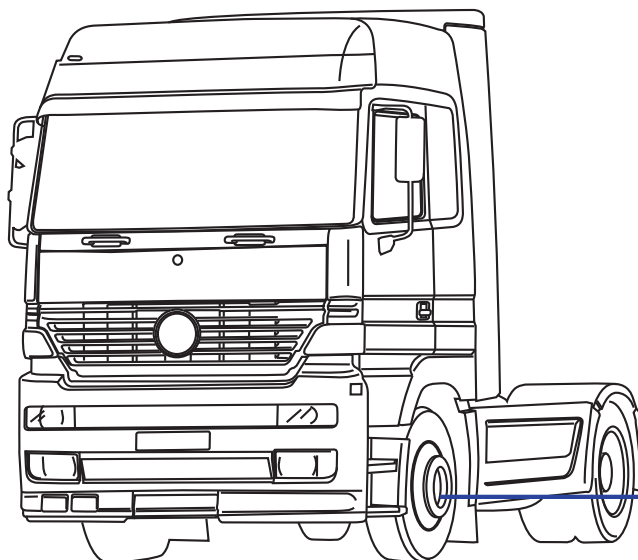

930/022 d/rh/rechts
930/023 s/lh/linki
c/scritta
with written
mit Emblem



930/032
acciaio inox
stainless steel
Edelstahl



930/132
plastica - cromato
plastic - chrome
Kunststoff - verchromt



930/122 d/rh/rechts
930/123 s/lh/linki
cerchi in lega
alloy wheels
Leichtmetallabdeckung

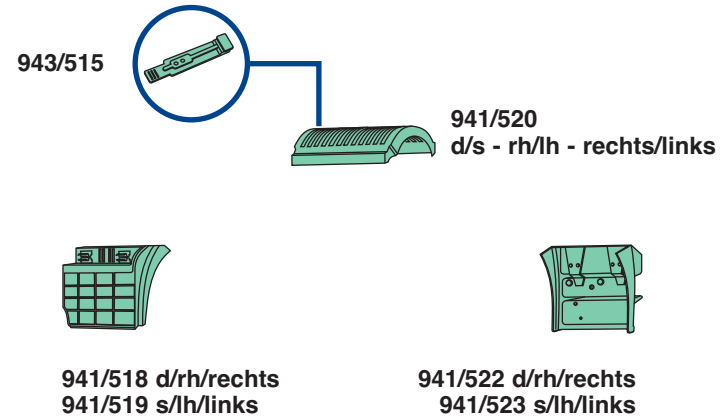
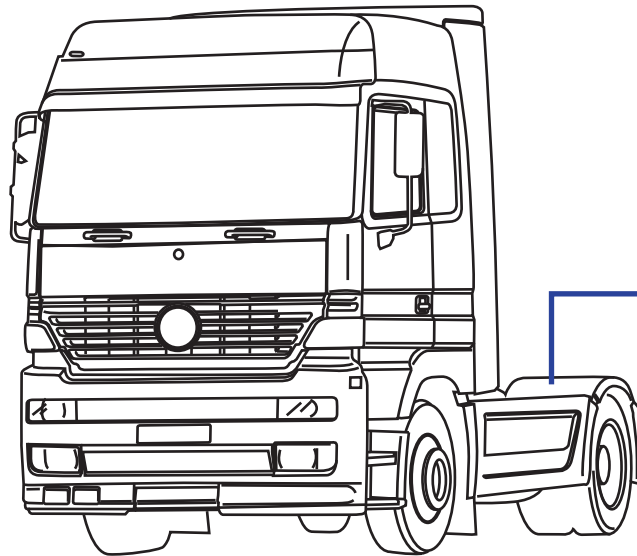

D
941/520
d/s - rh/lh
rechts/links

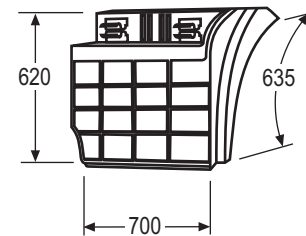
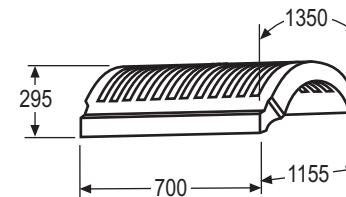

B
941/518 d/rh/rechts
941/519 s/lh/links

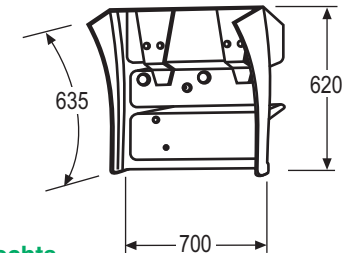

B
941/522 d/rh/rechts
941/523 s/lh/links

- A** con anti-spray/with anti-spray/mit Spritzschutz
- B** senza anti-spray/without anti-spray/ohne Spritzschutz
- C** con cinghietti/with stretcher/mit Befestigungsgummi
- D** senza cinghietti/without stretcher/ohne Befestigungsgummi

240/675

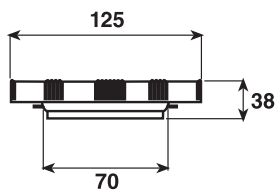

240/677

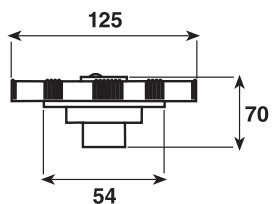

M20/670

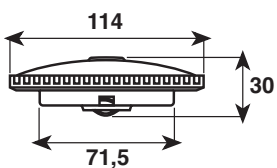

0FH/670

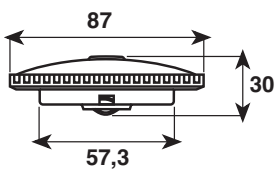

240/675
senza chiave
without key
ohne Schlüssel



240/677
con chiave
with key
mit Schlüssel



M20/670
con chiave
with key
mit Schlüssel



0FH/670
senza chiave
without key
ohne Schlüssel

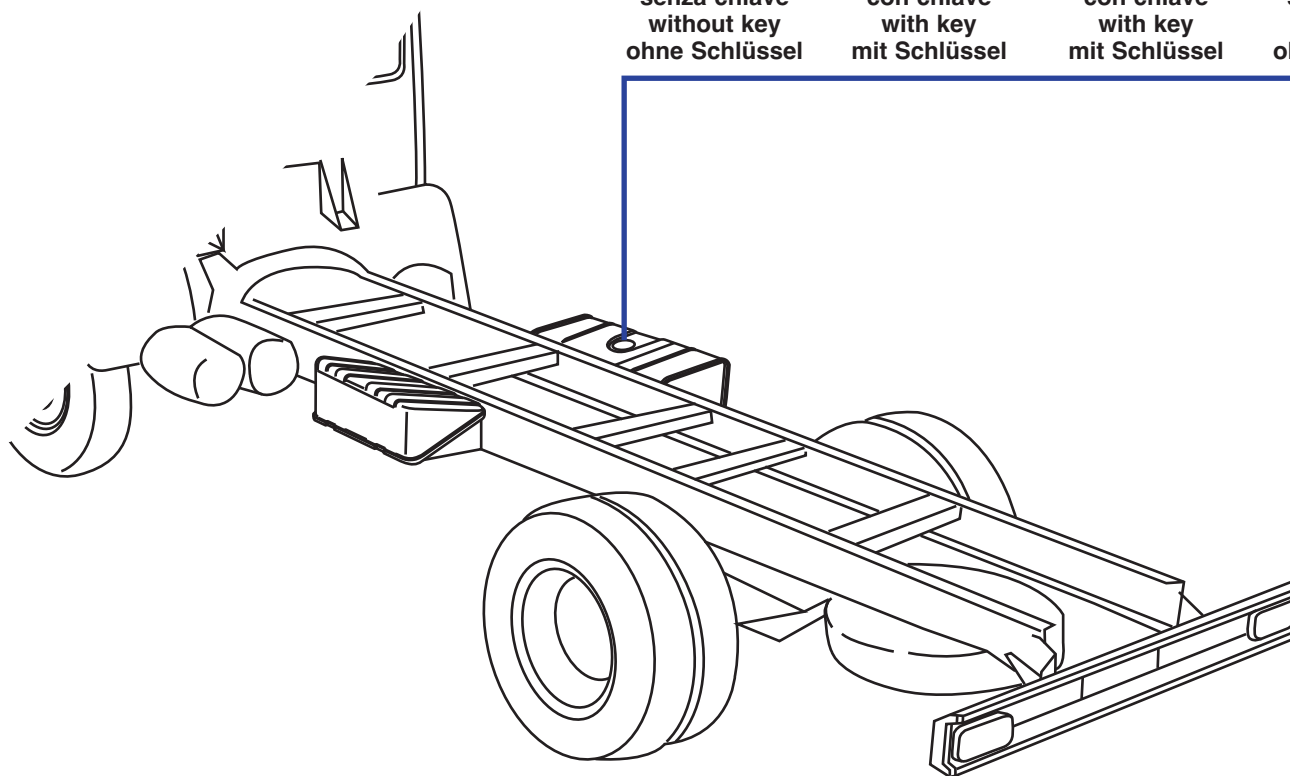



- ▲ IT Stampi per la realizzazione di componenti termoplastici
- UK molds for thermoplastic part production
- DE diverse Formen für die Thermoplastischen Produkte



- ▲ IT Linea di verniciatura con processo certificato
- UK painting line with certified process
- DE Lackierabteilung



- ▲ IT Reparto presse per lo stampaggio ad iniezione di componenti termoplastici
- UK production department for the injection pressing of thermoplastic parts
- DE Produktionsabteilung mit verschiedenen Pressen für thermoplastische Produkte

MERCEDES

MERCEDES-BENZ AXOR

seconda serie / second version / zweite Serie



143

MERCEDES·BENZ AXOR
 seconda serie / second version / zweite Serie

941/ 90

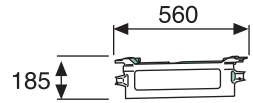

943/140

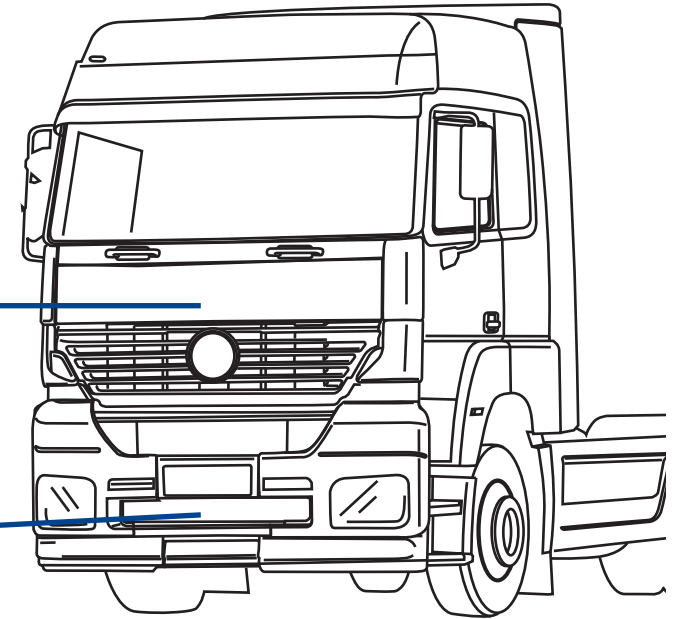

144

940/ 93
 alto - s/foro
 high - without hole
 hoch - ohne Lochausschnitt

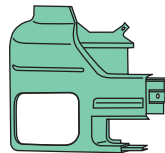

941/ 90

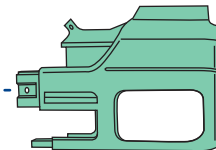

940/ 94
 alto - s/foro
 high - without hole
 hoch - ohne Lochausschnitt

941/ 94
 c/foro
 with hole
 mit Lochausschnitt

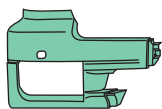

941/ 90

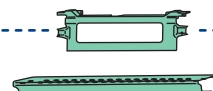

941/ 96

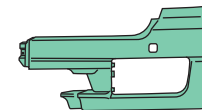

941/ 95
 c/foro
 with hole
 mit Lochausschnitt

940/ 82
 c/foro
 with hole
 mit Lochausschnitt



940/ 86
 s/foro
 without hole
 ohne Lochausschnitt



940/ 87
 s/foro
 without hole
 ohne Lochausschnitt



940/ 83
 c/foro
 with hole
 mit Lochausschnitt



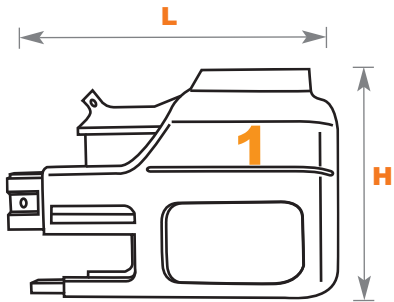

Legenda:
Key:
Legende:

1. Foro tergi faro
Headlight wipers
Scheinwerferreinigungsanlage



145

Codice Covind	Covind References	Covind Art. Nr.	Codice Originale	O.E. References	Vergleichs-Nr.	1	L	H	Peso	Weight	Gewicht	Colore	Color	Farbe	Materiale	Material	Material
940/ 93	d/rh/rechts		9448802404			x	935 mm	730 mm	7,200 kg.			grigio/grey/grau				SMC	
940/ 94	s/lh/links		9448800104			x	935 mm	730 mm	7,200 kg.			grigio/grey/grau				SMC	

146

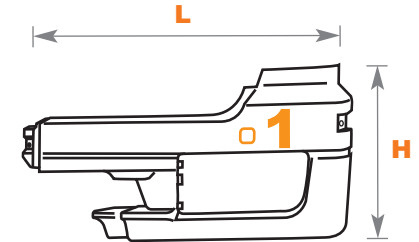

Legenda:
Key:
Legende:

1. Foro tergi faro
Headlight wipers
Scheinwerferreinigungsanlage

Codice Covind	Covind References	Covind Art. Nr.	Codice Originale	O.E. References	Vergleichs-Nr.	1	L	H	Peso	Weight	Gewicht	Colore	Color	Farbe	Materiale	Material	Material
941/ 94	d/rh/rechts		9418802470			✓	1000 mm	555 mm	5,300 kg.			grigio/grey/grau			SMC		
941/ 95	s/lh/links		9418802370			✓	1000 mm	555 mm	5,300 kg.			grigio/grey/grau			SMC		

MERCEDES·BENZ AXOR
seconda serie / second version / zweite Serie

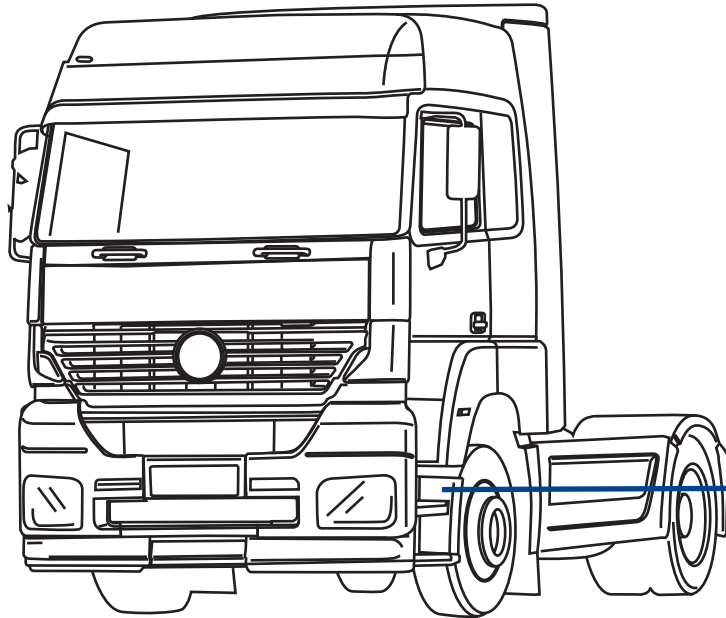

940/204 d/rh/rechts
940/205 s/lh/links
s/foro
without hole
ohne Lochausschnitt

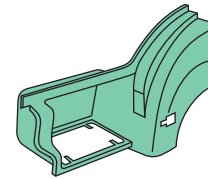

940/200 d/rh/rechts
940/201 s/lh/links
c/foro
with hole
mit Lochausschnitt

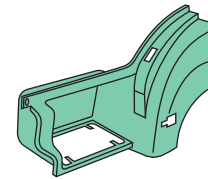

940/242 d/rh/rechts
940/243 s/lh/links



940/212 d/s-rh/lh-rechts + links



940/210 d/s-rh/lh-rechts + links

MERCEDES-BENZ AXOR seconda serie / second version / zweite Serie

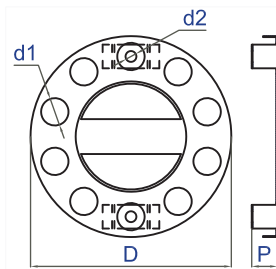

930/022 d/rh/rechts · 930/023 s/lh/links

D ø 425 mm	P 50 mm
d1 nr. 10	d1 ø 58 mm
d2 nr. 2	d2 ø 22,5 mm
Ventilata	si/yes/Ja
Ventilated/Belüftet	
Colore/Colours/Farbe	cromato/chrome/verchromt
Materiale/Material	acciaio inox e plastica stainless steel and plastic Edelstahl und Kunststoff
Kg	1,235

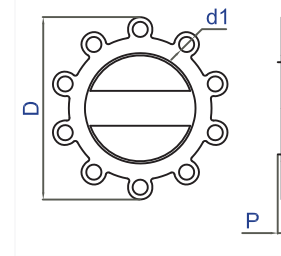

930/122 d/rh/rechts · 930/123 s/lh/links

D ø 387 mm	P 30 mm
d1 nr. 10	d1 ø 32 mm
Ventilata	si/yes/Ja
Ventilated/Belüftet	
Colore/Colours/Farbe	cromato e nero/chrome and black verchromt und schwarz
Materiale/Material	acciaio inox e plastica stainless steel and plastic Edelstahl und Kunststoff
Kg	0,655

930/032 - Tappo copri Bullone · Bolt cover · Radmutterkappen

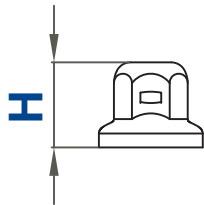

H	45 mm
Per bulloni ø / bolt ø	32 mm
Schlüsselweite ø	
Colore/Colours/Farbe	cromato/chrome/verchromt
Materiale/Material	acciaio inox/stainless steel Edelstahl
Kg	0,025

930/132 - Tappo copri Bullone · Bolt cover · Radmutterkappen

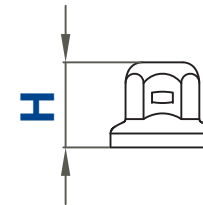

H	45 mm
Per bulloni ø / bolt ø	32 mm
Schlüsselweite ø	
Colore/Colours/Farbe	cromato/chrome/verchromt
Materiale/Material	plastica/plastic/Kunststoff
Kg	0,014

148

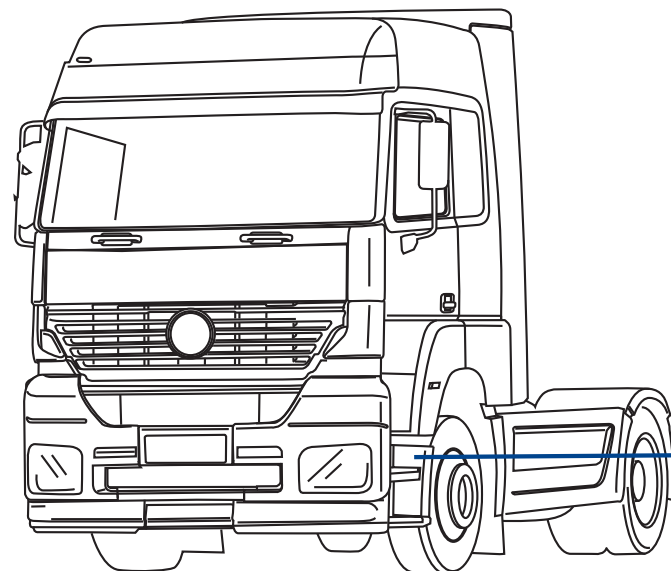

930/022 d/rh/rechts
930/023 s/lh/links
c/scritta
with written
mit Emblem



930/032
acciaio inox
stainless steel
Edelstahl



930/132
plastica - cromato
plastic - chrome
Kunststoff - verchromt

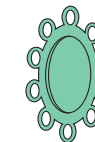

930/122 d/rh/rechts
930/123 s/lh/links
cerchi in lega
alloy wheels
Leichtmetallabdeckung

MERCEDES-BENZ AXOR
seconda serie / second version / zweite Serie

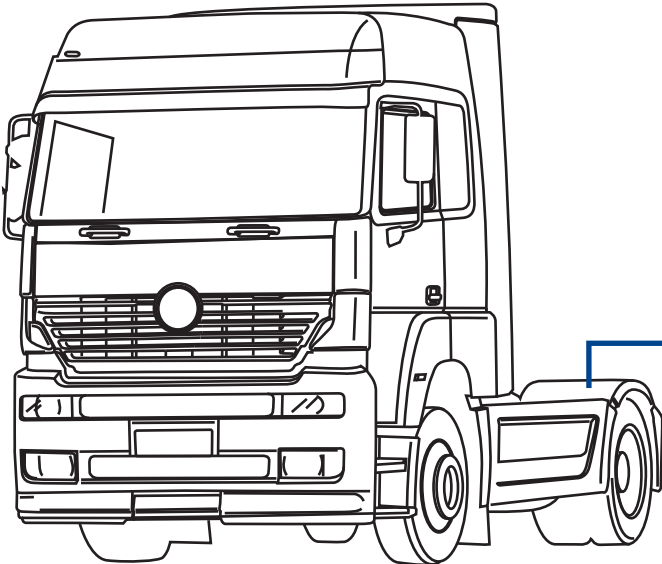

943/515



943/520
d/s - rh/lh - rechts/links



943/525
d/s - rh/lh - rechts/links

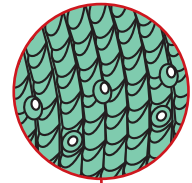

943/518
d/s-rh/lh
rechts/links

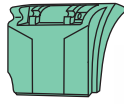

943/516 d/rh/rechts
943/517 s/lh/links



943/550
d/s - rh/lh
rechts/links

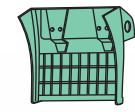

943/519
d/s-rh/lh
rechts/links

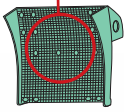

943/555
d/s - rh/lh
rechts/links

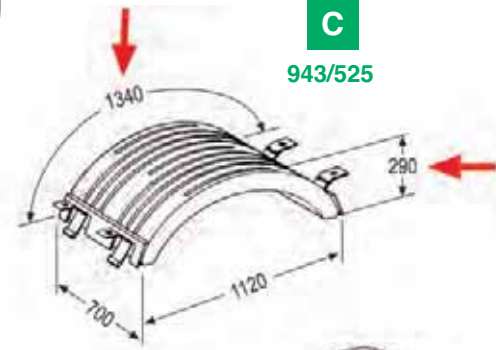

C
943/525

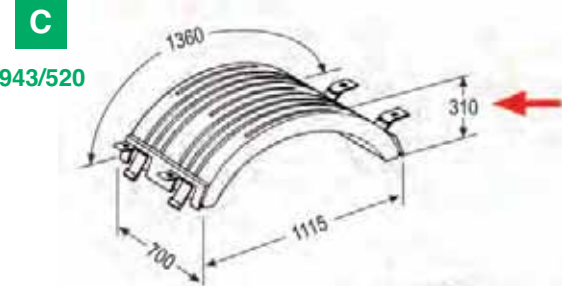

C
943/520



B
943/516 d/rh/rechts
943/517 s/lh/links

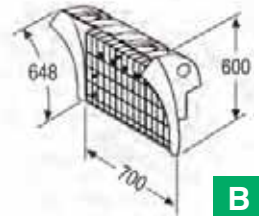

B
943/519
d/s-rh/lh-rechts/links

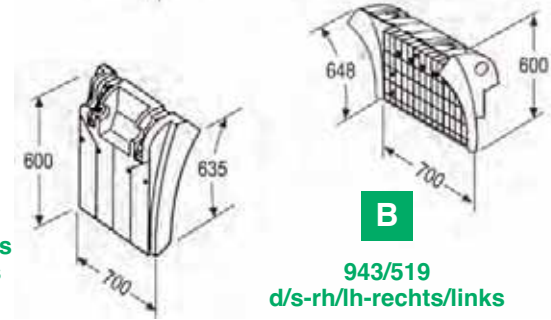

B
943/519
d/s-rh/lh-rechts/links

- A** con anti-spray/with anti-spray/mit Spritzschutz
- B** senza anti-spray/without anti-spray/ohne Spritzschutz
- C** con cinghietti/with stretcher/mit Befestigungsgummi
- D** senza cinghietti/without stretcher/ohne Befestigungsgummi

B
943/516 d/rh/rechts
943/517 s/lh/links

A
943/518
d/s-rh/lh-rechts/links



- ▲ IT Robot di foratura e taglio laser
- UK Laser drilling and cutting robot
- DE Laserbeschneidung und Schneideroboter

MERCEDES

MERCEDES-BENZ AXOR

prima serie / first version / erste Serie

151





- ▲ IT Calibro di controllo per il collaudo di un frontale destinato ad un veicolo Renault
- UK Setting gauge for testing of the front part for a Renault vehicle
- DE Einstellehre zur Prüfung für die Frontklappe 385/145 (Renault)

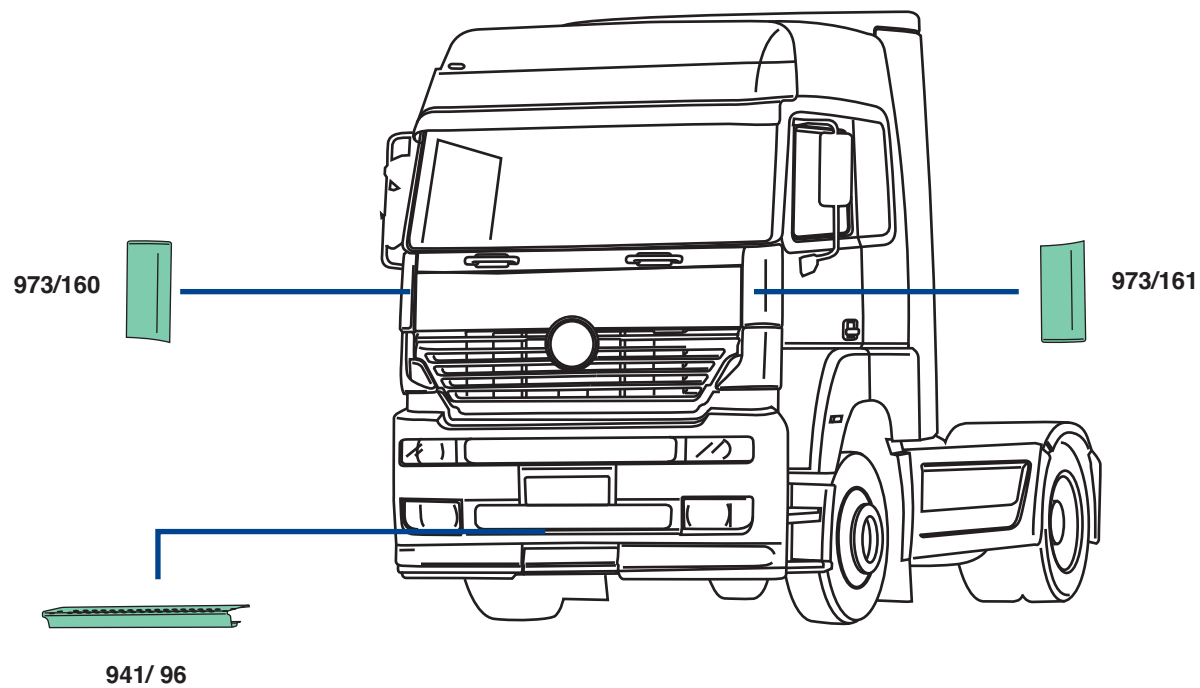

MERCEDES-BENZ AXOR
prima serie / first version / erste Serie

154

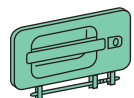
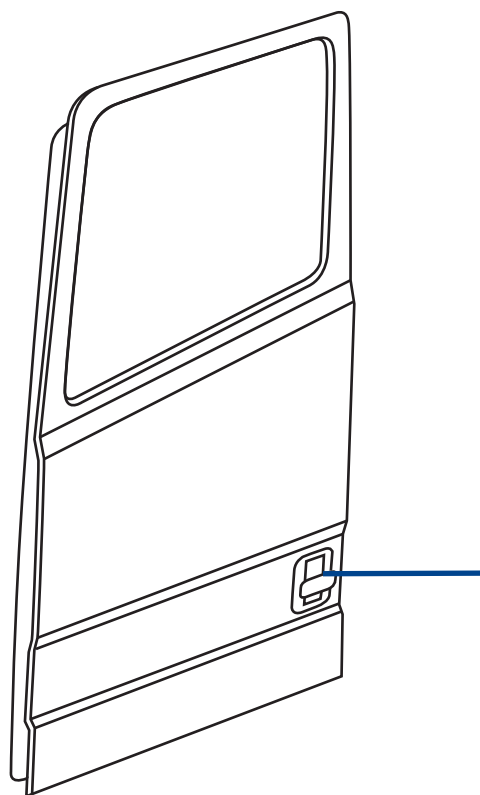

941/148 d/rh/rechts
941/149 s/lh/links
s/chiave
without key
ohne Schlüssel

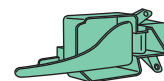

941/172 d/rh/rechts
941/173 s/lh/links
per alzavetro manuale
for window lifter-manual
manuell

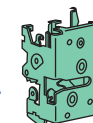
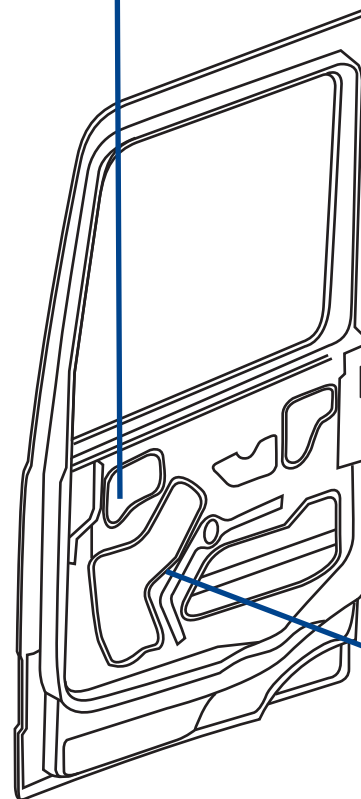

941/176 d/rh/rechts
941/177 s/lh/links

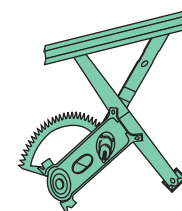

941/174 d/rh/rechts
941/175 s/lh/links
manuale
manual
manuell

MERCEDES-BENZ AXOR
prima serie / first version / erste Serie

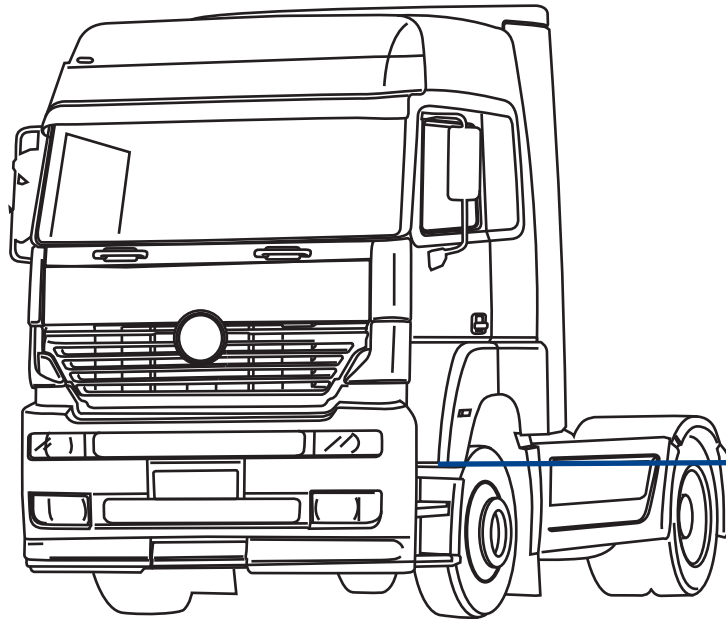

940/204 d/rh/rechts
940/205 s/lh/links
s/foro
without hole
ohne Lochausschnitt

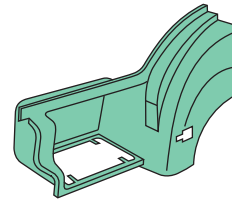

940/200 d/rh/rechts
940/201 s/lh/links
c/foro
with hole
mit Lochausschnitt

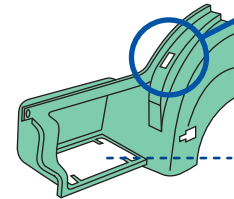

940/240 d/rh/rechts
940/241 s/lh/links

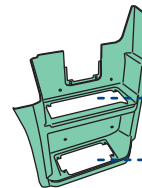

940/242 d/rh/rechts
940/243 s/lh/links

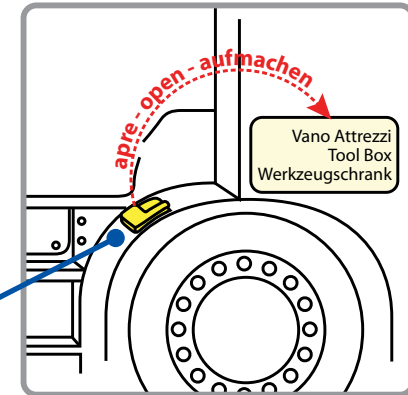
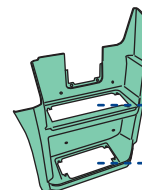

940/212 d/s-rh/lh-rechts + links

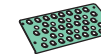

940/212 d/s-rh/lh-rechts + links

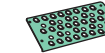

940/210 d/s-rh/lh-rechts + links

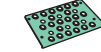

940/212 d/s-rh/lh-rechts + links

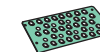

940/210 d/s-rh/lh-rechts + links



MERCEDES-BENZ AXOR
prima serie / first version / erste Serie

156

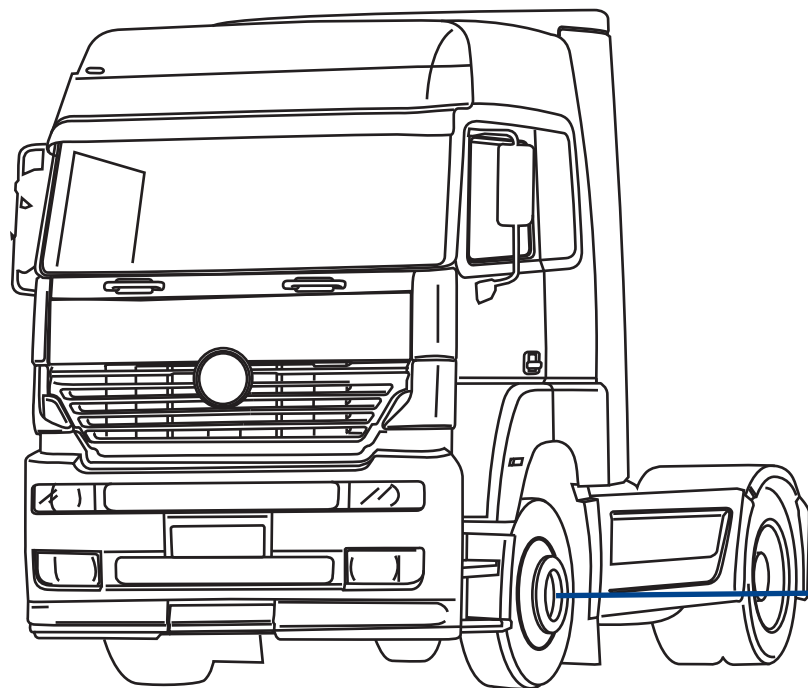

930/032
acciaio inox
stainless steel
Edelstahl

930/132
plastica - cromato
plastic - chrome
Kunststoff - verchromt



930/022 d/rh/rechts
930/023 s/lh/links
c/scrivita
with written
mit Emblem

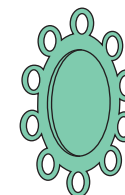

930/122 d/rh/rechts
930/123 s/lh/links
cerchi in lega
alloy wheels
Leichtmetallabdeckung

930/022 d/rh - 023 s/lh

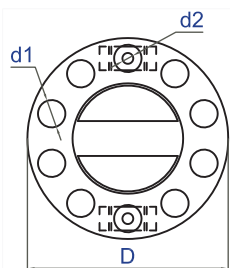

D ø	425 mm	P	50 mm
d1 nr.	10	d1 ø	58 mm
d2 nr.	2	d2 ø	22,5 mm
Ventilata/Ventilated	si/yes		
Colore/Colours	cromata/chrome		
Materiale/Material	acciaio inox e plastica stainless steel and plastic		
Kg	1,235		

930/122 d/rh · 930/123 s/lh

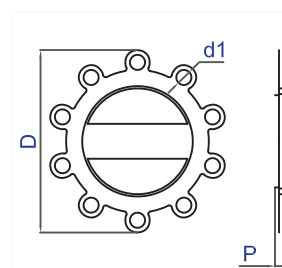

D ø	387 mm	P	30 mm
d1 nr.	10	d1 ø	32 mm
Ventilata/Ventilated	si/yes		
Colore/Colours	cromato e nero chrome and black		
Materiale/Material	acciaio inox e plastica stainless steel and plastic		
Kg	0,655		

930/032 - Tappo copri Bullone - Bolt cover

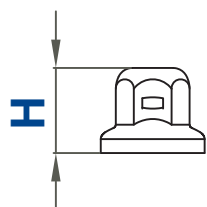

H	45 mm
Per bulloni ø	32 mm
Colore/Colours	cromato/chrome
Materiale/Material	acciaio inox/stainless steel
Kg	0,025

930/132 - Tappo copri Bullone - Bolt cover

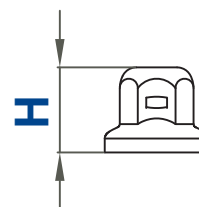

H	45 mm
Per bulloni ø	32 mm
Colore/Colours	cromato/chrome
Materiale/Material	plastica/plastic
Kg	0,014

MERCEDES-BENZ AXOR prima serie / first version / erste Serie

158

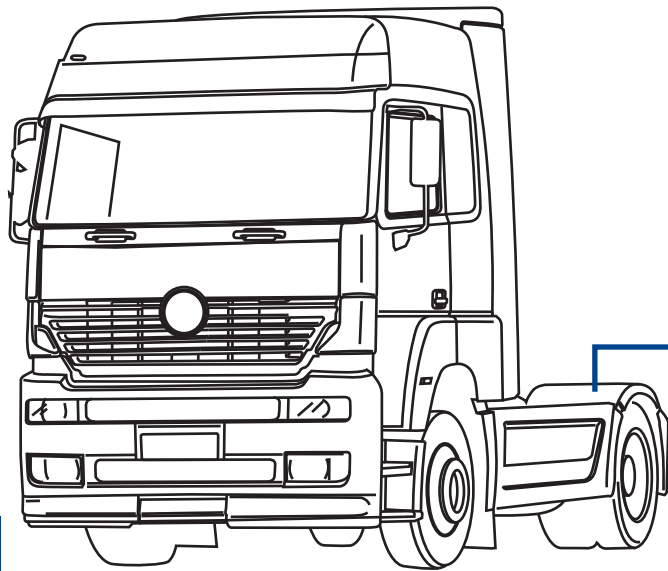

943/515

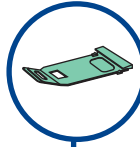

943/520
d/s - rh/lh - rechts/links



943/525
d/s - rh/lh - rechts/links

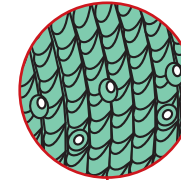
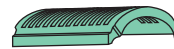

943/518
d/s-rh/lh
rechts/links



943/516 d/rh/rechts
943/517 s/lh/links

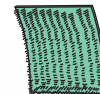

943/550
d/s - rh/lh
rechts/links

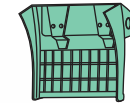

943/519
d/s-rh/lh
rechts/links

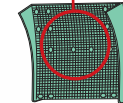

943/555
d/s - rh/lh
rechts/links

C
943/525

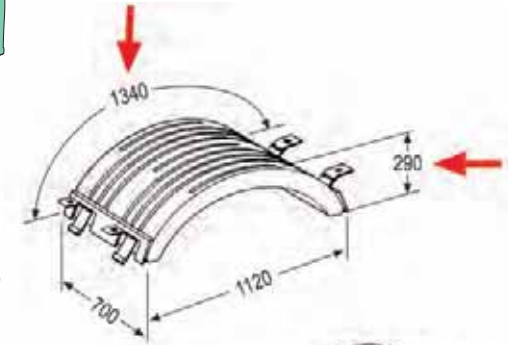

C

943/520

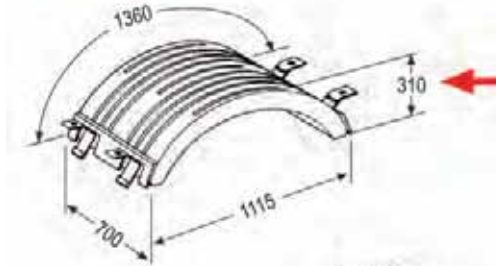

A con anti-spray/with anti-spray/mit Spritzschutz

B senza anti-spray/without anti-spray/ohne Spritzschutz

C con cinghietti/with stretcher/mit Befestigungsgummi

D senza cinghietti/without stretcher/ohne Befestigungsgummi

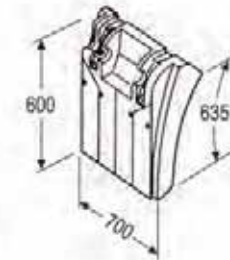

B

943/516 d/rh/rechts
943/517 s/lh/links

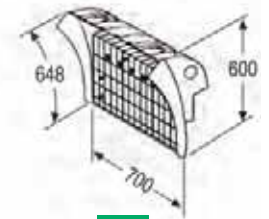

B

943/519
d/s-rh/lh-rechts/links

A

943/518
d/s-rh/lh-rechts/links

B

943/516 d/rh/rechts
943/517 s/lh/links

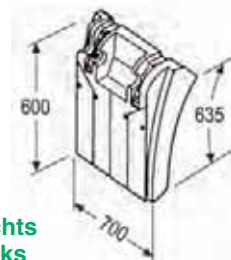

B

943/519
d/s-rh/lh-rechts/links

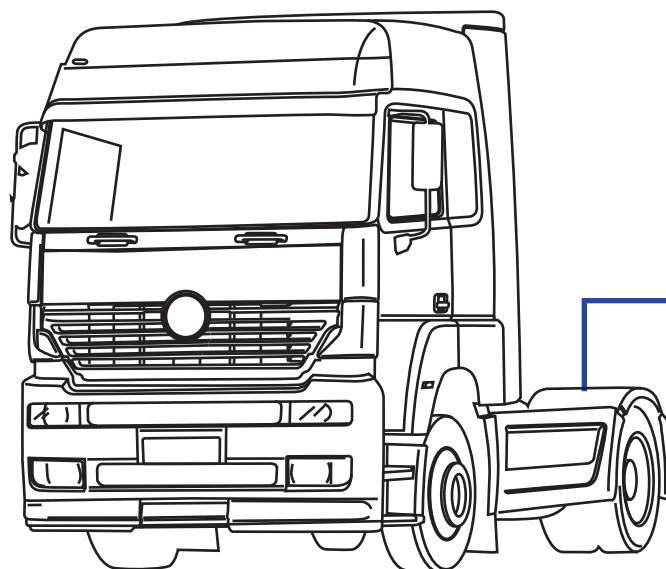

941/515



941/520
d/s - rh/lh - rechts/links



941/518 d/rh/rechts
941/519 s/lh/links



941/522 d/rh/rechts
941/523 s/lh/links



159

D

941/520
d/s - rh/lh
rechts/links

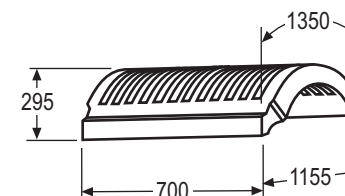

B

941/518 d/rh/rechts
941/519 s/lh/links

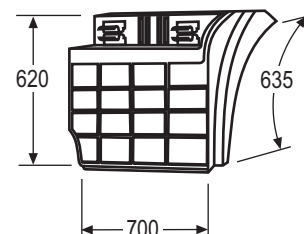

B

941/522 d/rh/rechts
941/523 s/lh/links

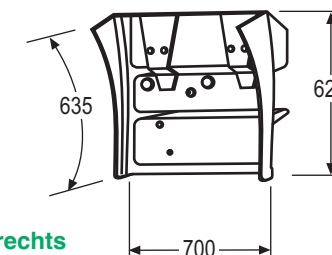

- A** con anti-spray/with anti-spray/mit Spritzschutz
- B** senza anti-spray/without anti-spray/ohne Spritzschutz
- C** con cinghietti/with stretcher/mit Befestigungsgummi
- D** senza cinghietti/without stretcher/ohne Befestigungsgummi



▲ IT Stampo in acciaio temprato per la realizzazione di un cantonale paraurti in SMC

UK Hardened steel mold for bumper corner in SMC production

DE offene gehärtete Stahlform für SMC Stosstangen Produktion

MERCEDES

MERCEDES-BENZ ATEGO

seconda serie / second version / zweite Serie



161

MERCEDES-BENZ ATEGO
seconda serie / second version / zweite Serie

162

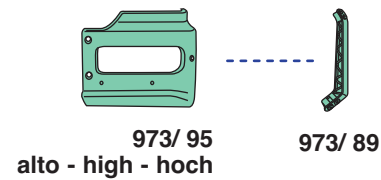
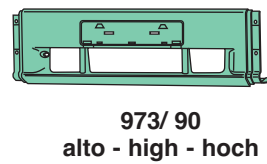
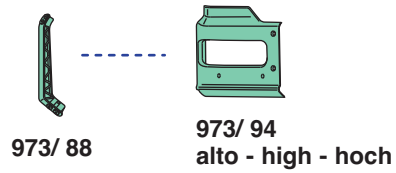
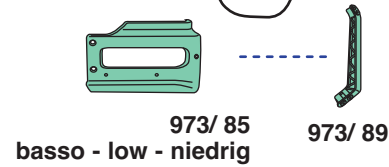
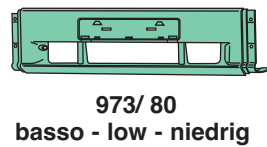
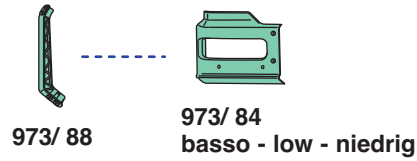
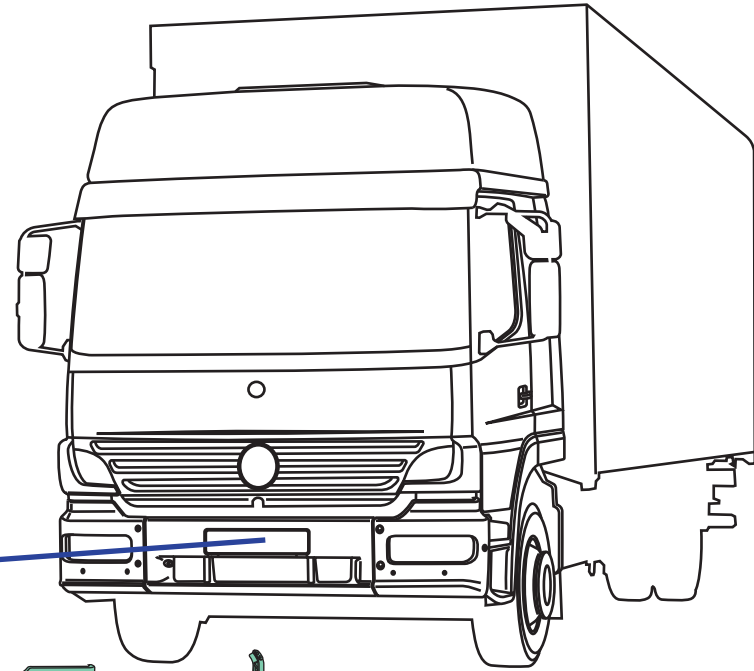

MERCEDES-BENZ ATEGO
seconda serie / second version / zweite Serie

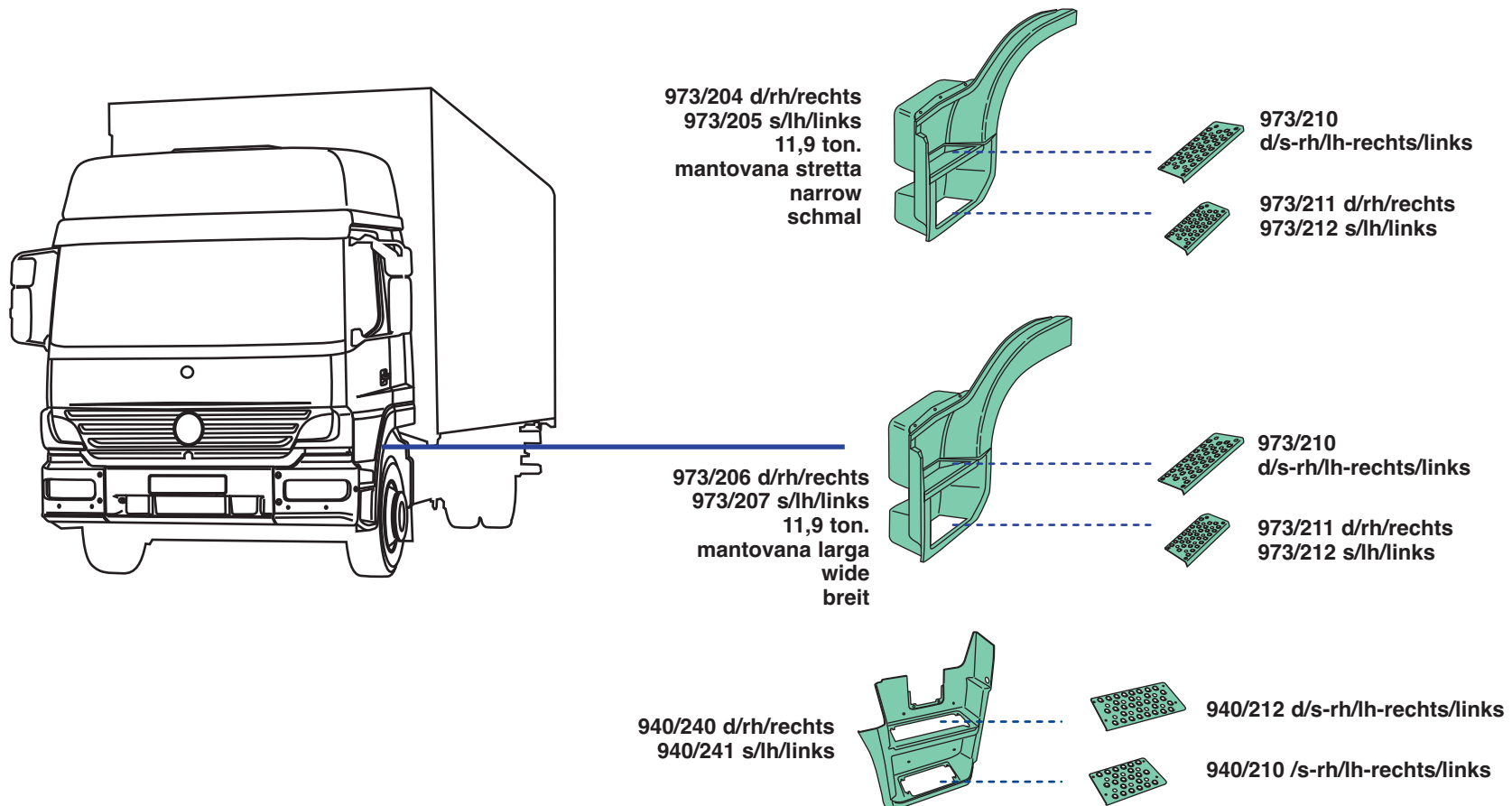

MERCEDES-BENZ ATEGO
seconda serie / second version / zweite Serie

164

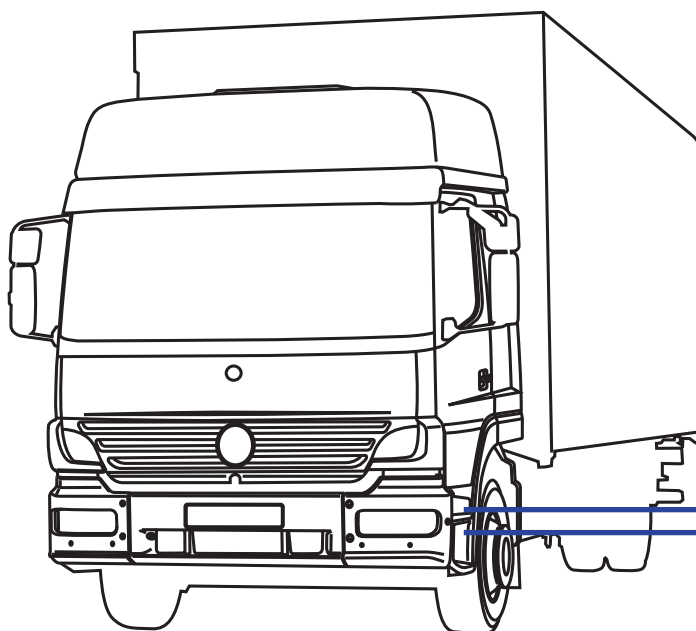

973/200 d/rh/rechts
973/201 s/lh/links
mantovana stretta
narrow - schmal

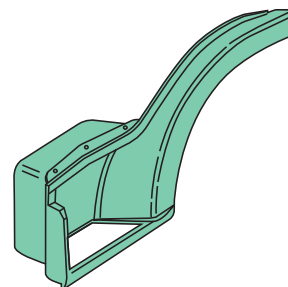

973/202 d/rh/rechts
973/203 s/lh/links
mantovana larga
wide - breit

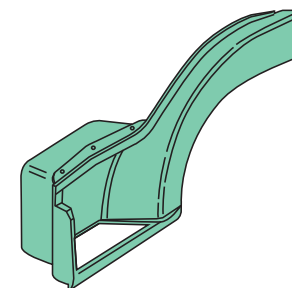

MERCEDES-BENZ ATEGO
seconda serie / second version / zweite Serie

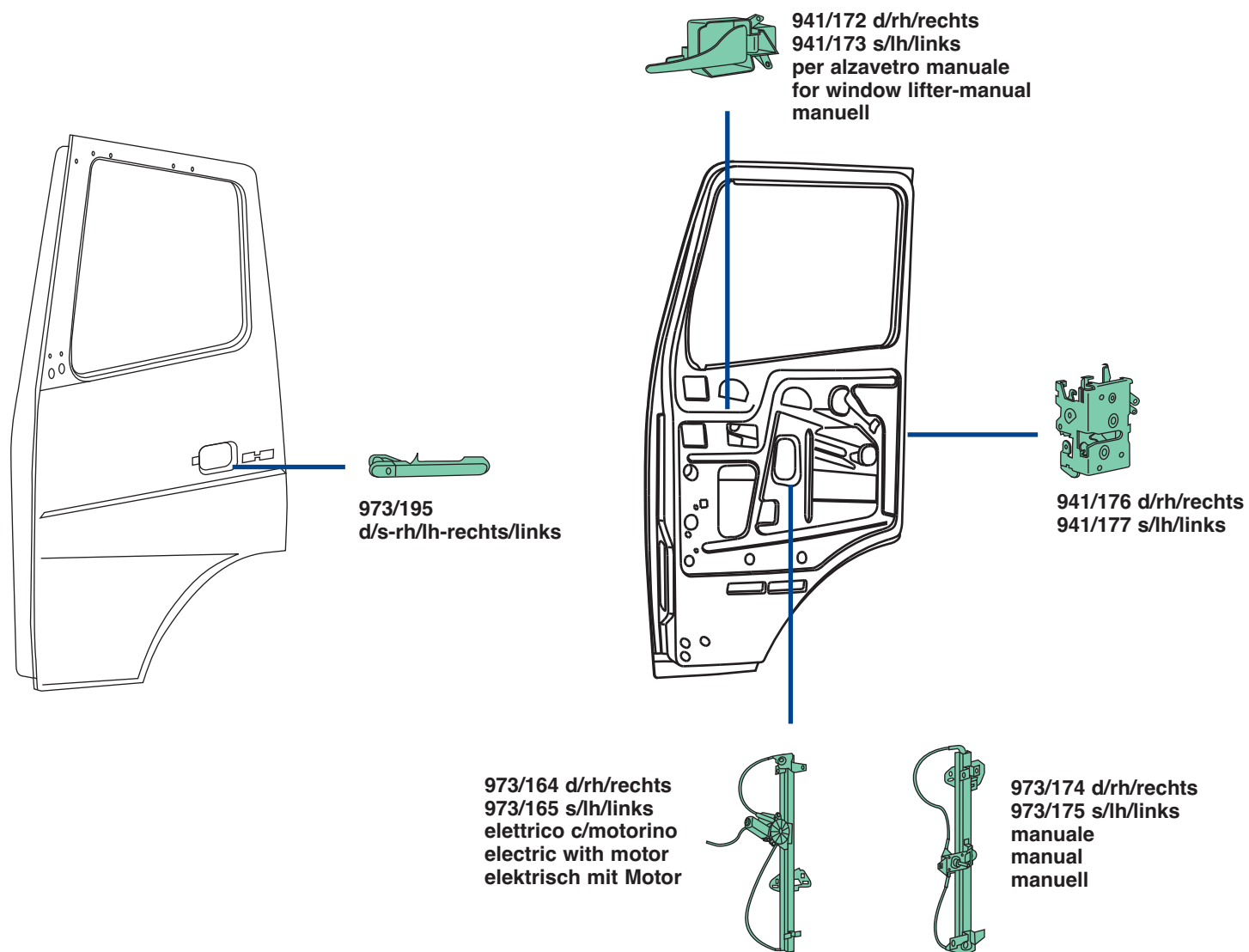



- ▲ IT Calibro per il controllo geometrico di un paraurti in polipropilene
- UK Setting gauge for the geometrical control of a polipropilen bumper
- DE Einstellehre für die geometrische Kontrolle für Polypropylen Stossstangen

MERCEDES

MERCEDES-BENZ ATEGO
prima serie / first version / erste Serie



167

MERCEDES-BENZ ATEGO
prima serie / first version / erste Serie

168

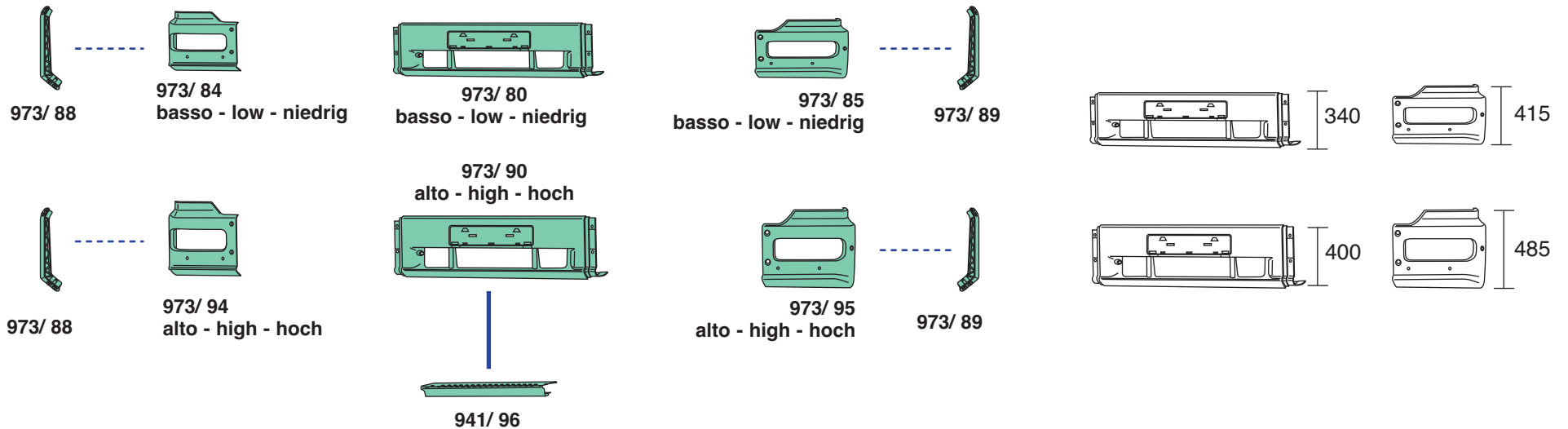
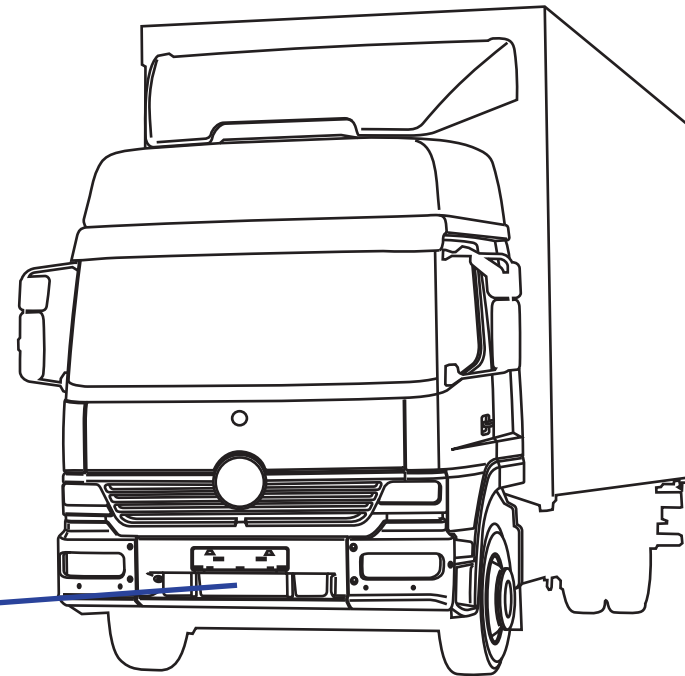

MERCEDES-BENZ ATEGO
prima serie / first version / erste Serie

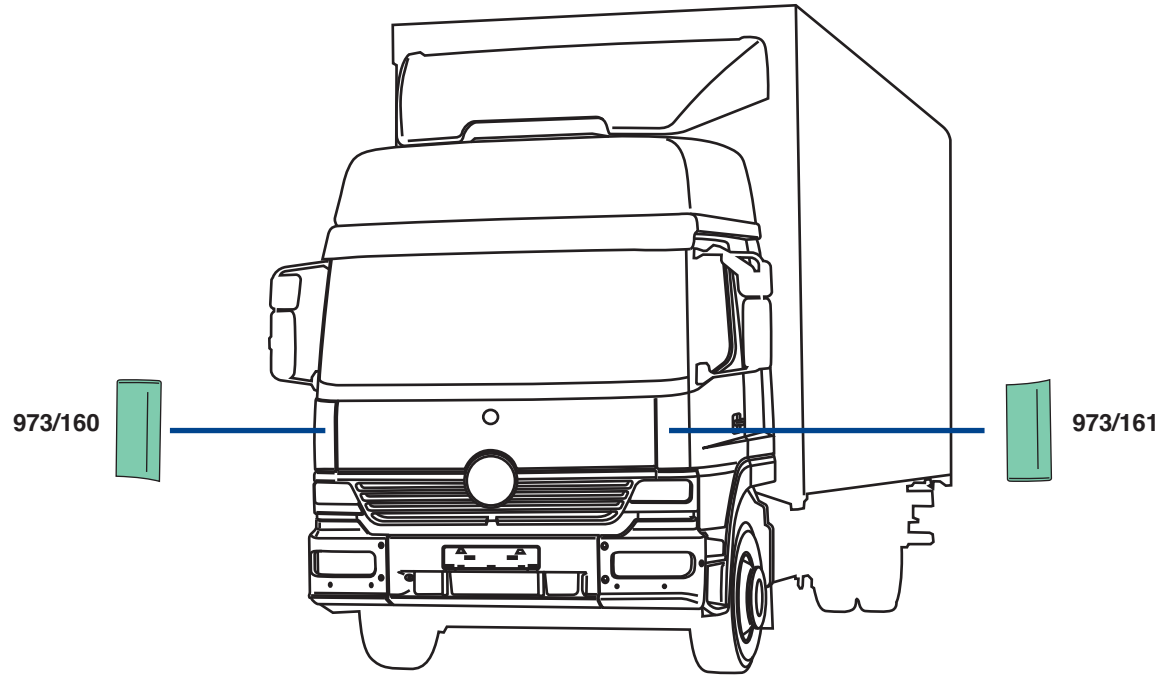

MERCEDES-BENZ ATEGO
prima serie / first version / erste Serie

170

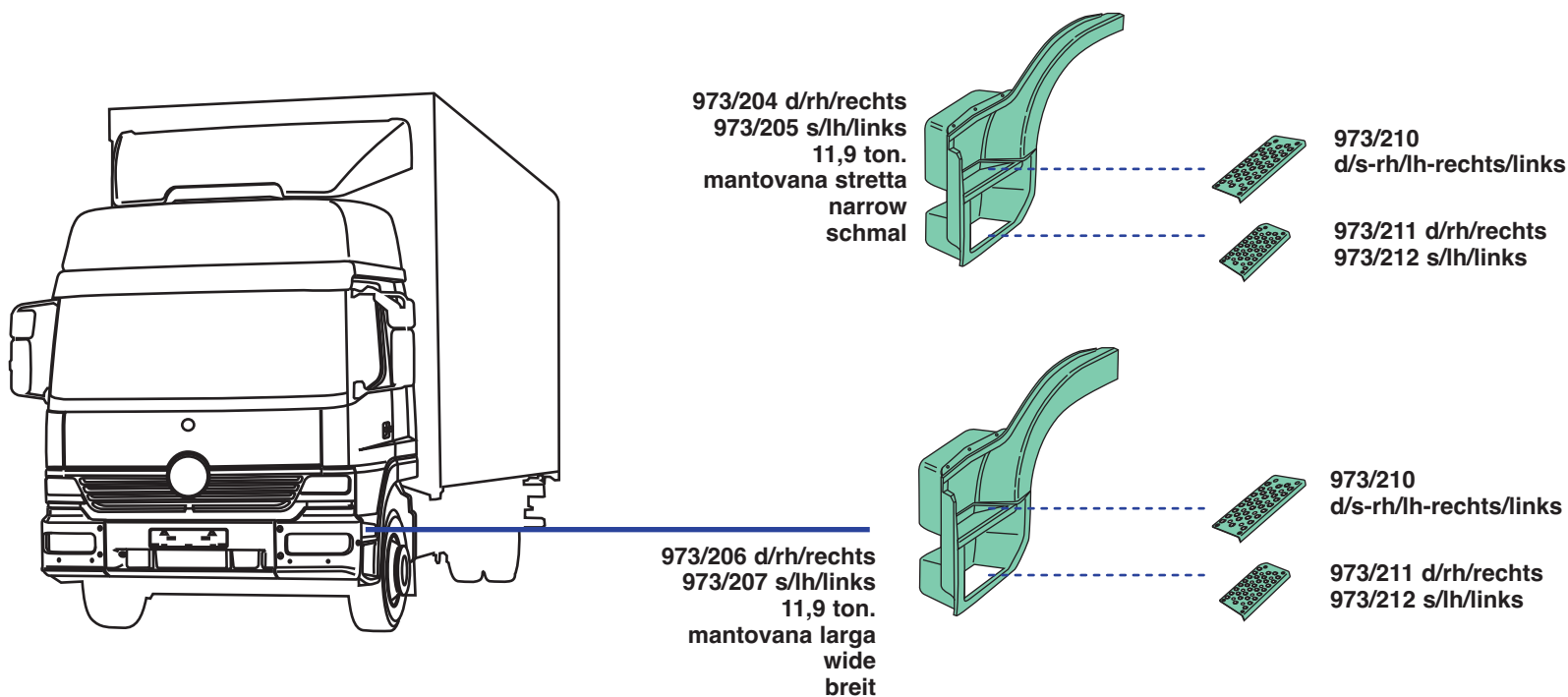

MERCEDES-BENZ ATEGO
prima serie / first version / erste Serie

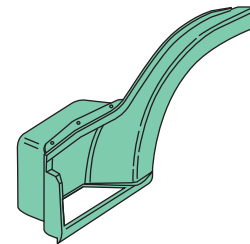
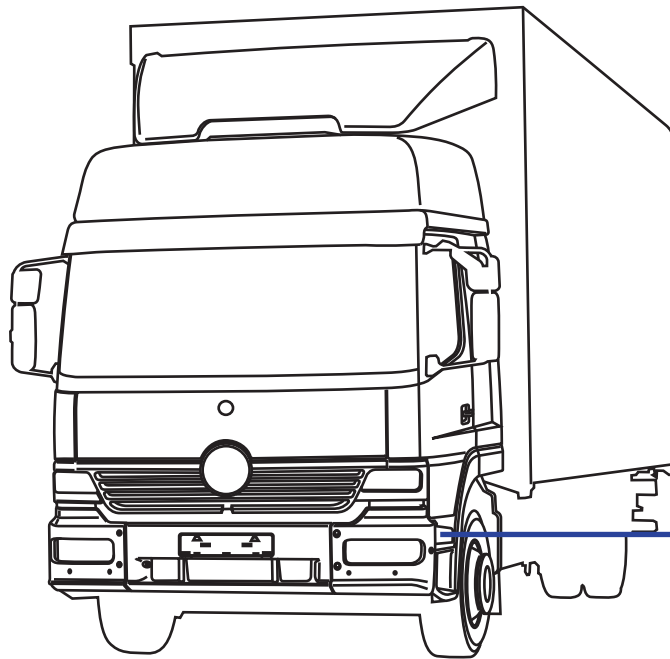

973/200 d/rh/rechts
973/201 s/lh/links
mantovana stretta
narrow
schmal

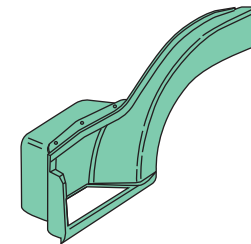

973/202 d/rh/rechts
973/203 s/lh/links
mantovana larga
wide
breit

MERCEDES-BENZ ATEGO
prima serie / first version / erste Serie

172

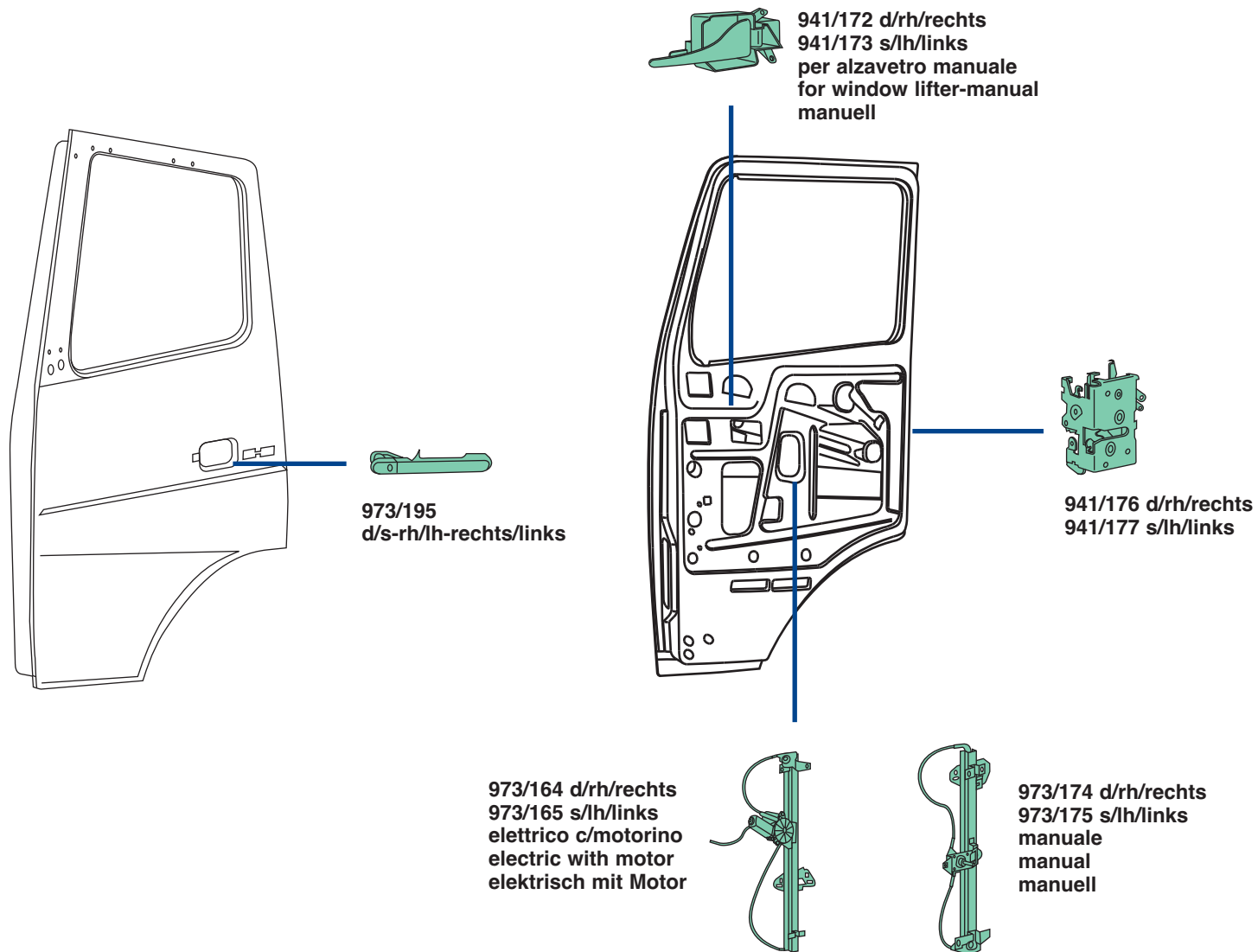

MERCEDES

MERCEDES-BENZ MB670
814-1320-1324

173



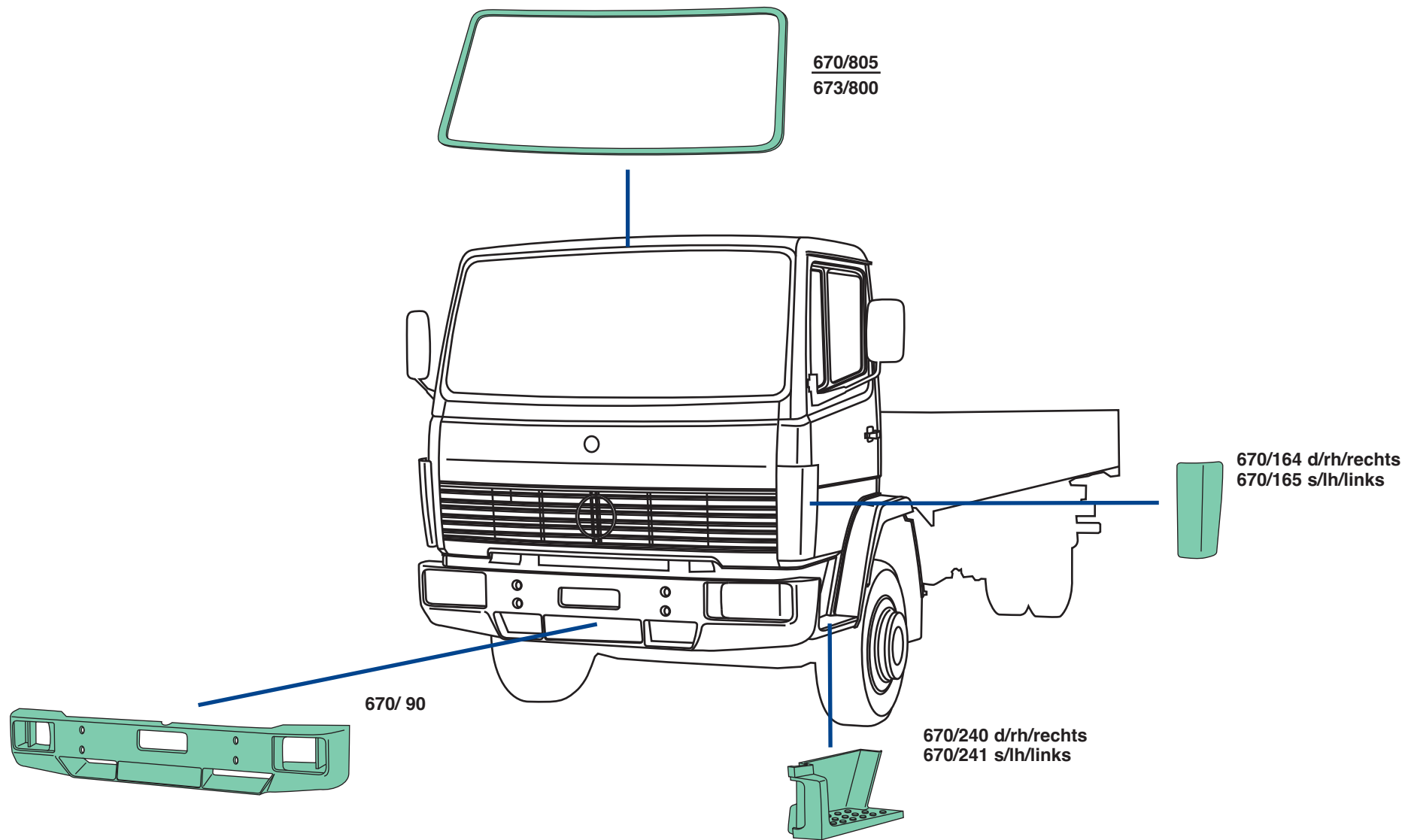

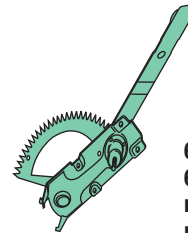
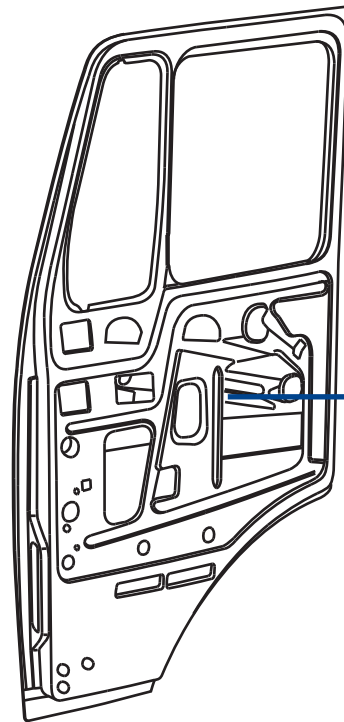

670/174 d/rh/rechts
670/175 s/lh/links
manuale
manual
manuell



- ▲ IT Fase di lucidatura
- UK polishing activity
- DE Polierabteilung



MERCEDES

**MERCEDES-BENZ MB649
1838-1838I-1850-1853-1948S-1948LS-2435**

177



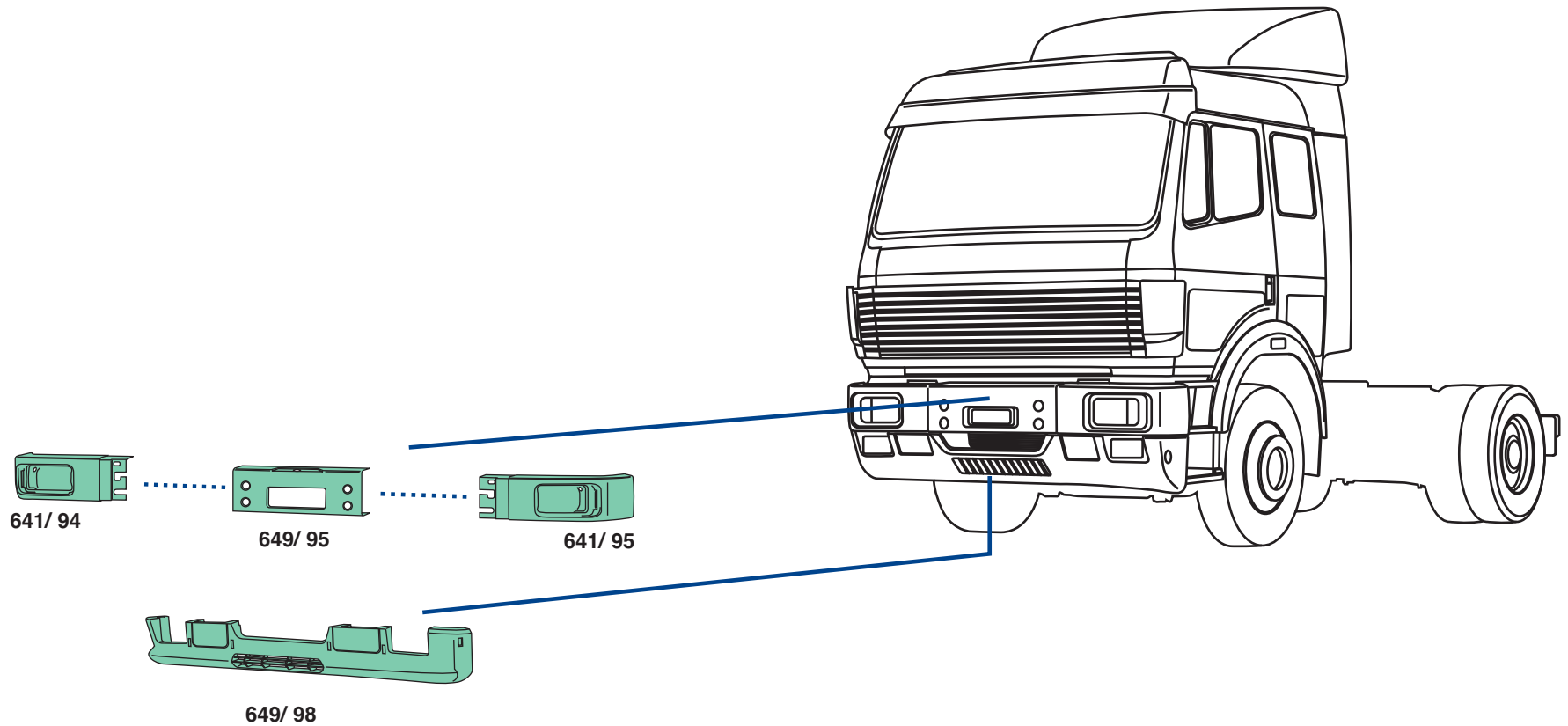

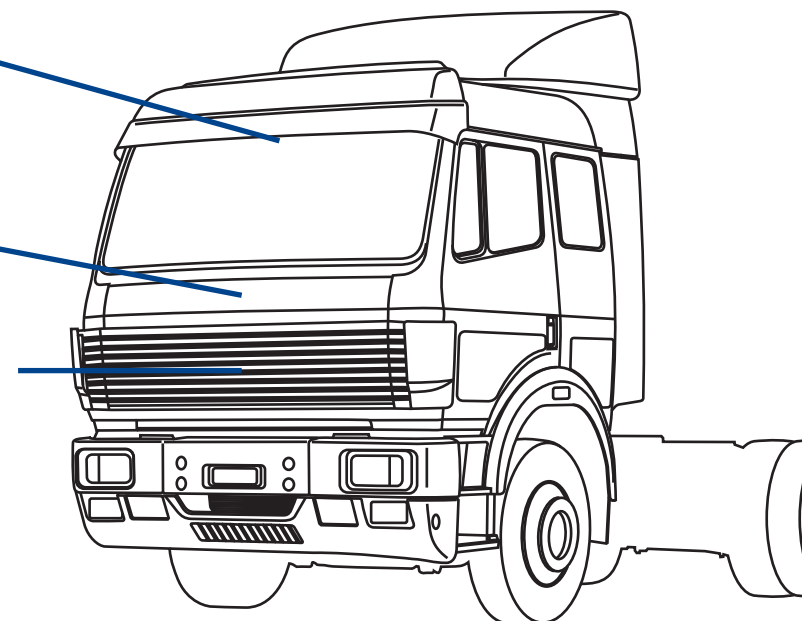
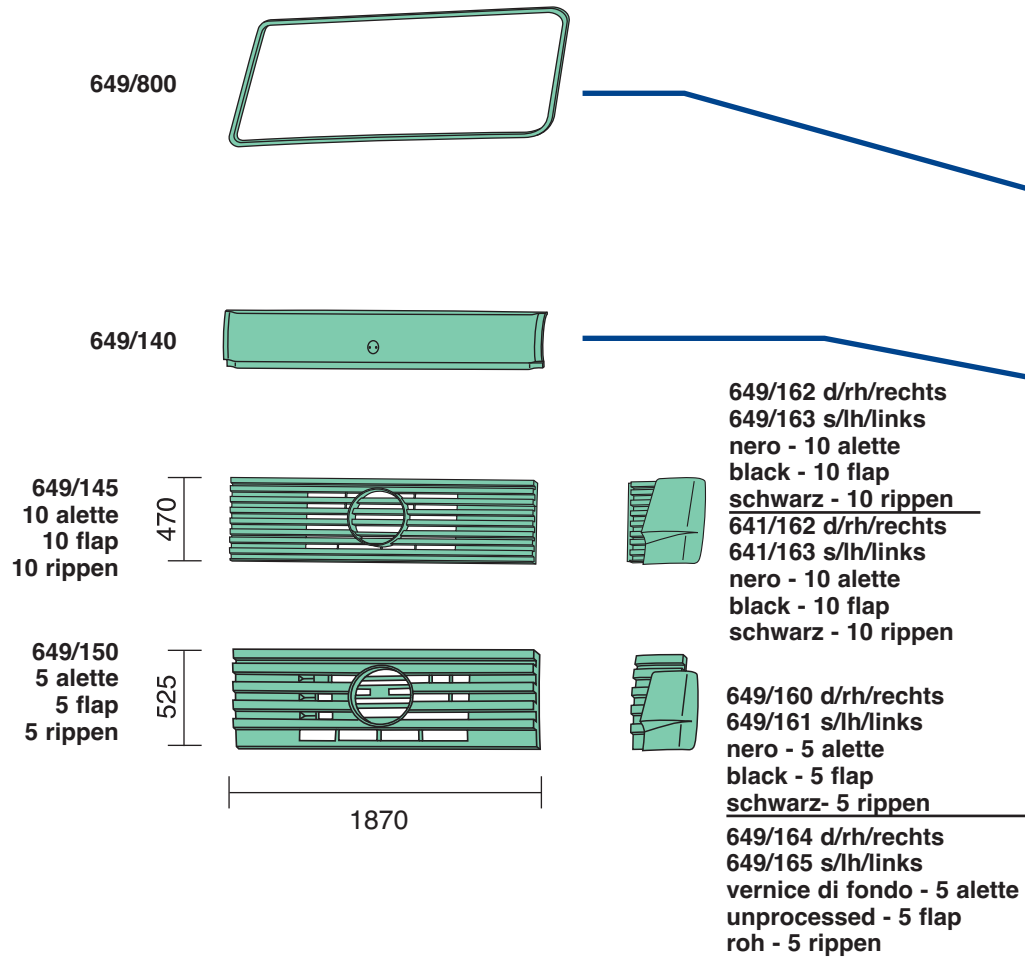

180

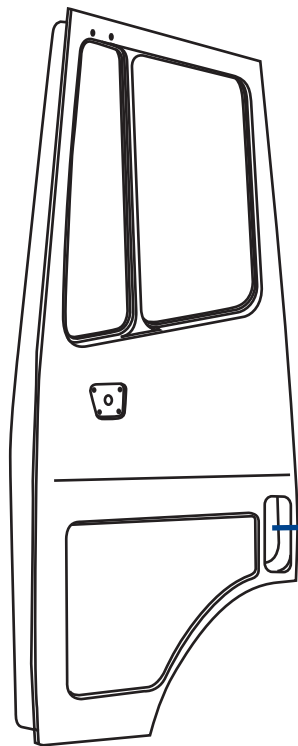

641/194 d/rh/rechts
641/195 s/lh/links
maniglia con chiave
handle with key
Türgriff mit Schlüssel

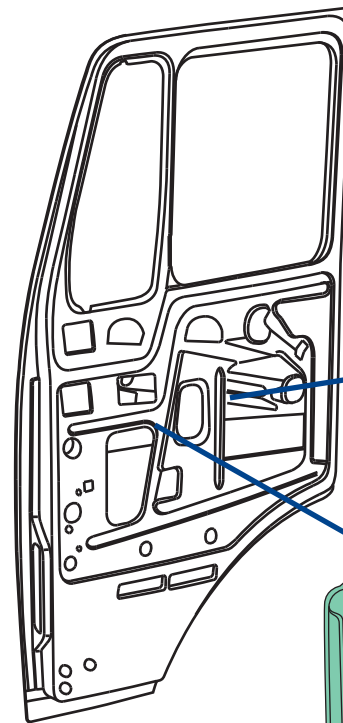

641/174 d/rh/rechts
641/175 s/lh/links
manuale
manual
manuel

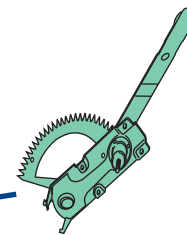

641/ 10 d/rh/rechts
641/ 11 s/lh/links

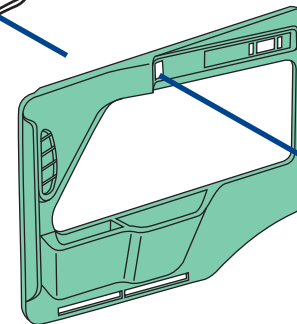

641/170
d/s-rh/lh-rechts/links

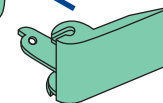

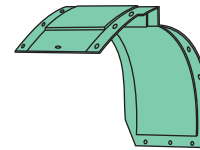
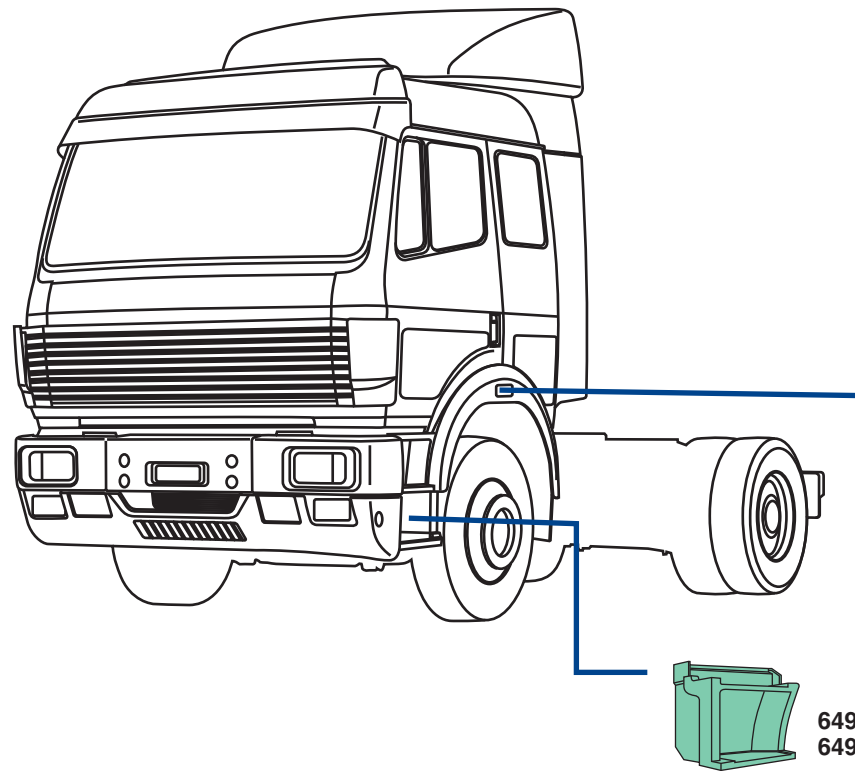

649/320 d/rh/rechts
649/321 s/lh/links

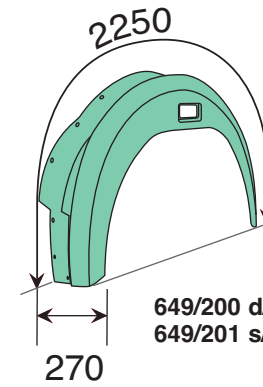

649/200 d/rh/rechts
649/201 s/lh/links

240/675

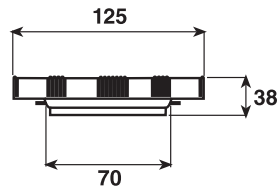

240/677

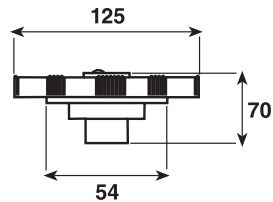

M20/670

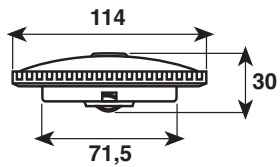

0FH/670

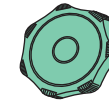
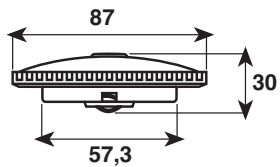

240/675
senza chiave
without key
ohne Schlüssel

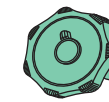

240/677
con chiave
with key
mit Schlüssel



M20/670
con chiave
with key
mit Schlüssel

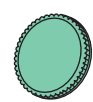

0FH/670
senza chiave
without key
ohne Schlüssel

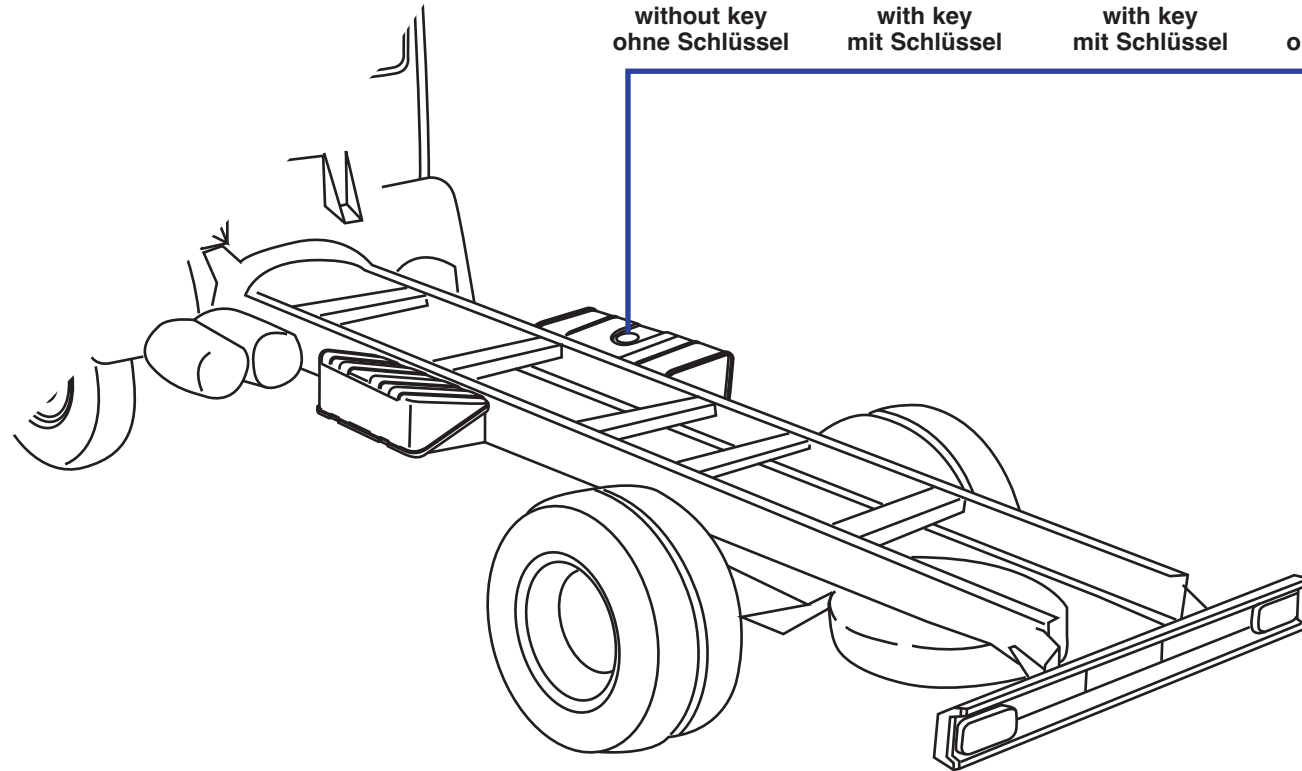



- ▲ IT Dettaglio dell'innesto delle boccole filettate in ottone per l'ancoraggio del paraurti
- UK details of the plug in of brass threaded sleeves for bumper clamping
- DE Detailabbildung - eingepresste Messinggewindebuchsen für Befestigung

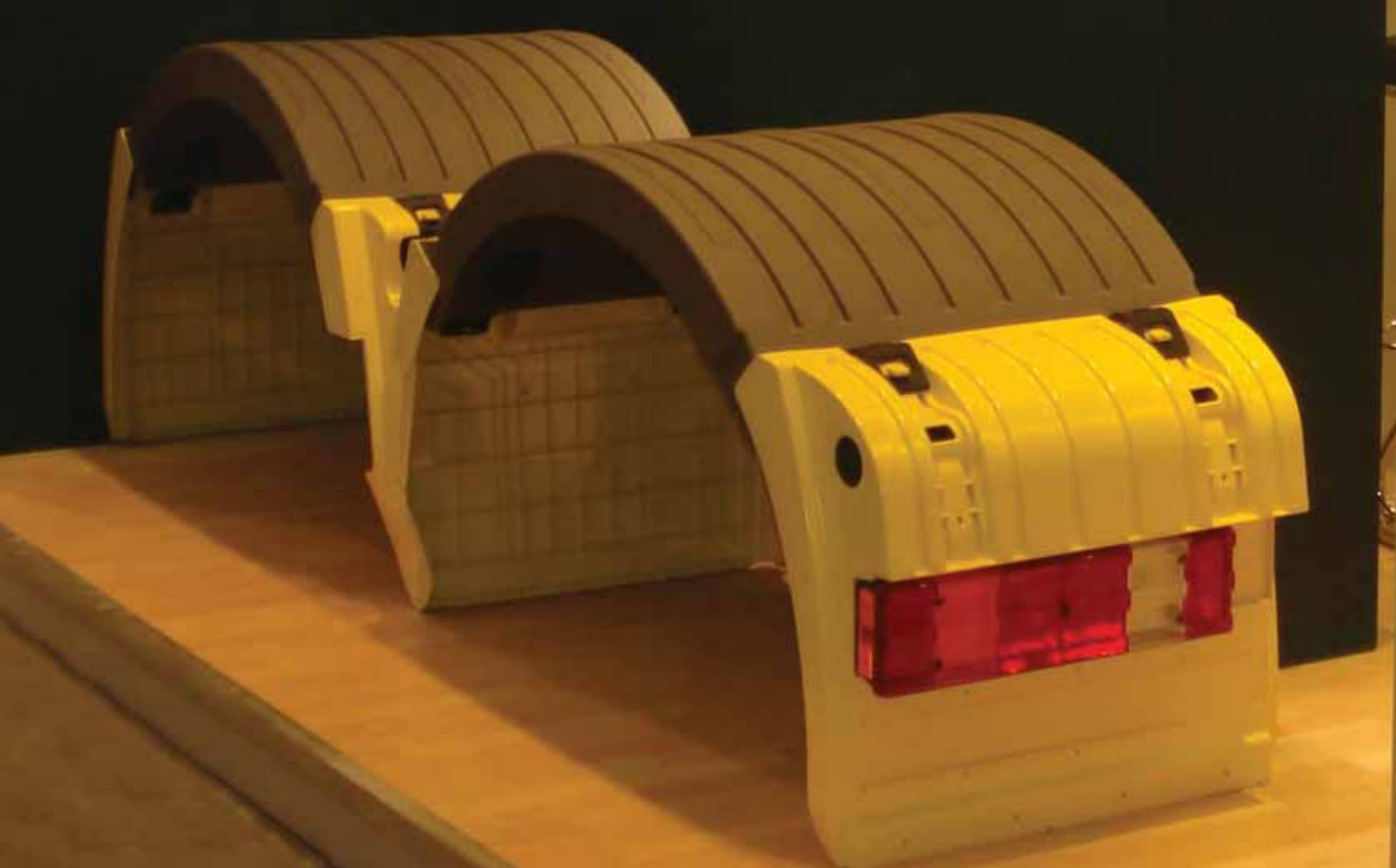

- ▲ IT Esempio di prodotto finito
- UK Finish product example
- DE fertige Produkte

MERCEDES

MERCEDES-BENZ MB641 POWERLINER

1820-1826-1827-1831-1834-1935-1935L-1948

2433-2534-2527B-2635-1838-2535



185

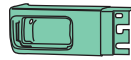
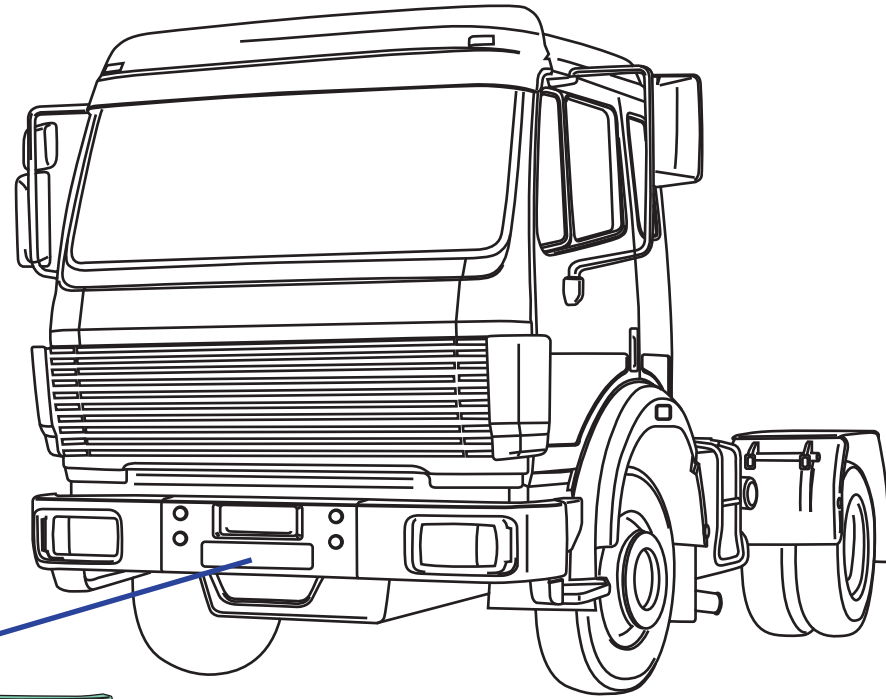

641/ 94



641/ 90



641/ 95



641/ 91

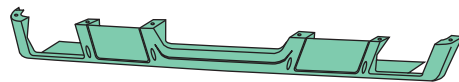

641/ 96

641/800



641/140



641/145

525



641/150

470



641/155

470

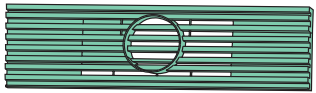

1870

649/160 d/rh/rechts
649/161 s/lh/links
nero - 5 alette
black - 5 flap
schwarz- 5 rippen

649/164 d/rh/rechts
649/165 s/lh/links
vernice di fondo - 5 alette
unprocessed - 5 flap
roh - 5 rippen

641/162 d/rh/rechts
641/163 s/lh/links
nero - 10 alette
black - 10 flap
schwarz - 10 rippen

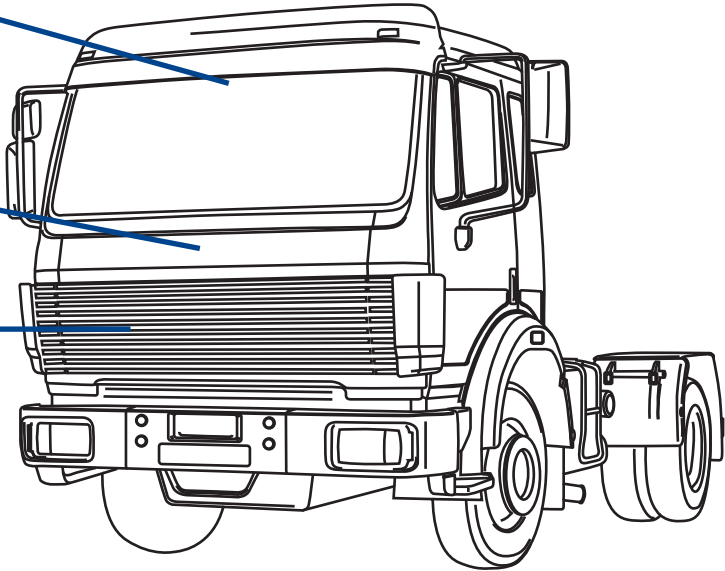

188

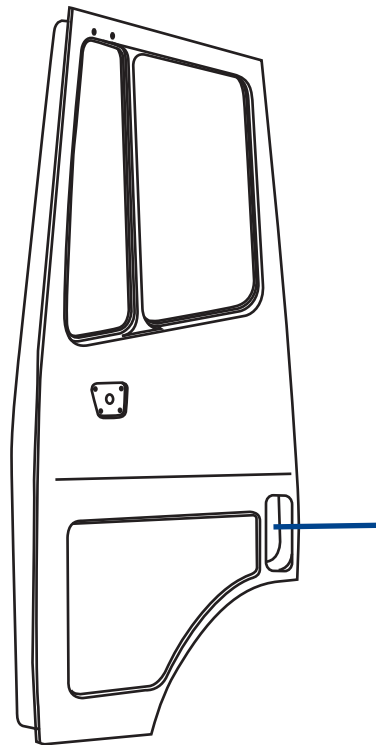

641/194 d/rh/rechts
641/195 s/lh/links
maniglia con chiave
handle with key
Türgriff mit Schlüssel

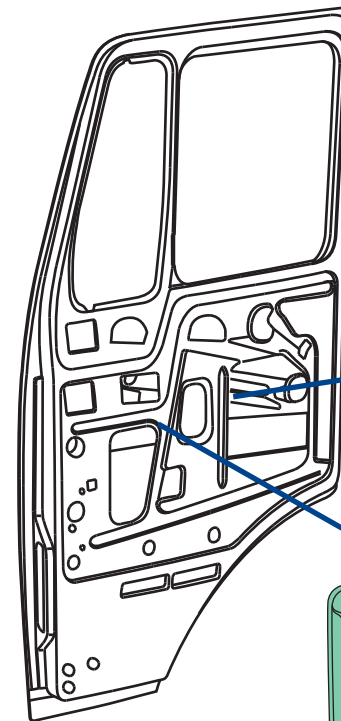

641/174 d/rh/rechts
641/175 s/lh/links
manuale
manual
manuell

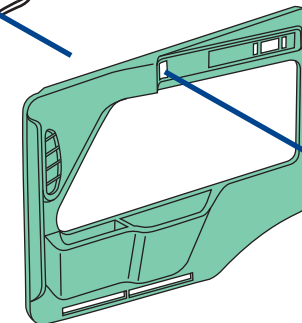

641/ 10 d/rh/rechts
641/ 11 s/lh/links

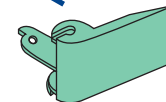

641/170
d/s-rh/lh-rechts/links

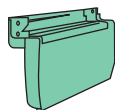
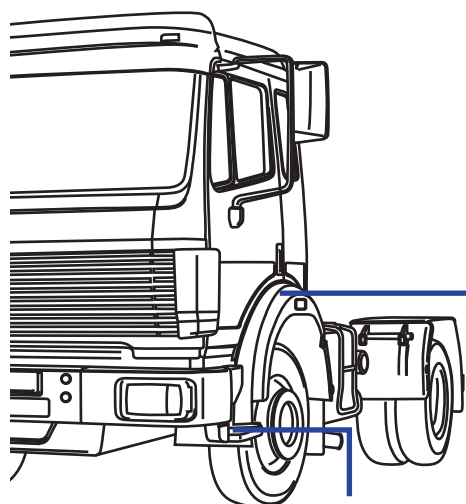

641/250 d/rh/rechts
641/251 s/lh/links

641/240 d/rh/rechts
641/241 s/lh/links

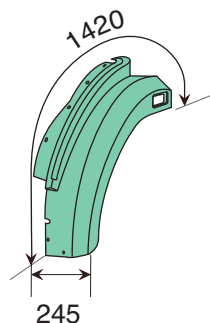

641/214 d/rh/rechts
641/215 s/lh/links
cabina alta-corta.
high cab, short type
kurzes Fhs. - 80 mm erhöht

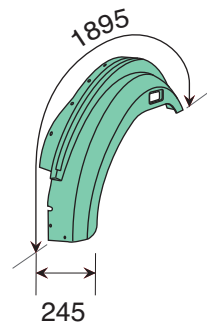

641/210 d/rh/rechts
641/211 s/lh/links
cabina alta-media.
high cab, medium type
mittell. Fhs. - 80 mm erhöht

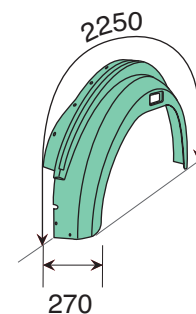

641/198 d/rh/rechts
641/199 s/lh/links
cabina alta- lunga
high cab, long type
langes Fhs. - 80 mm erhöht

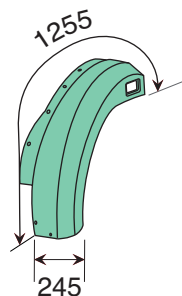

641/202 d/rh/rechts
641/203 s/lh/links
cabina bassa-corta.
low cab, short type
kurzes Fhs.

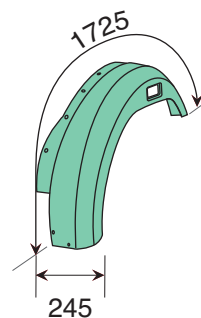

641/204 d/rh/rechts
641/205 s/lh/links
cabina bassa-media
low cab, medium type
mittell. Fhs.

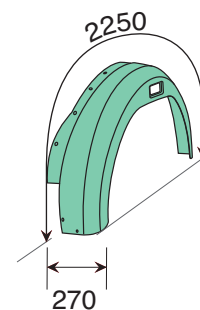

641/200 d/rh/rechts
641/201 s/lh/links
cabina bassa-lunga
low cab, long type
langes Fhs.

MERCEDES-BENZ MB641 POWERLINER

1820-1826-1827-1831-1834-1935-1935L-1948-2433-2534-2527B-2635-1838-2535

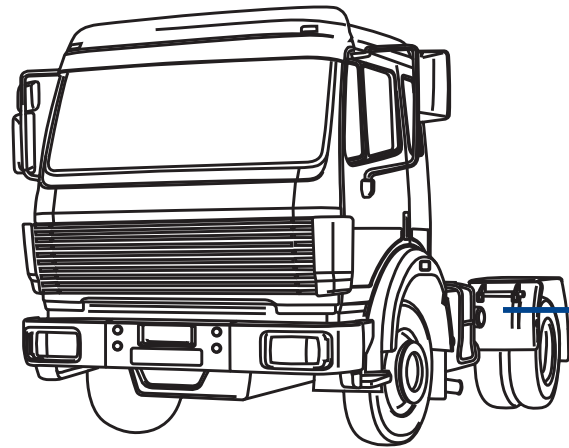

641/525

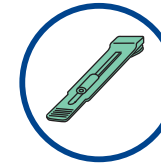

641/515
circolare - circular - kreisförmig
d/s - rh/lh - rechts/links



641/520
semi piatta - semi-flat - halbflach
d/s - rh/lh - rechts/links



641/510
d/s - rh/lh - rechts/links

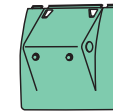

641/510
d/s - rh/lh - rechts/links



190

- A** con anti-spray/with anti-spray/mit Spritzschutz
- B** senza anti-spray/without anti-spray/ohne Spritzschutz
- C** con cinghietti/with stretcher/mit Befestigungsgummi
- D** senza cinghietti/without stretcher/ohne Befestigungsgummi

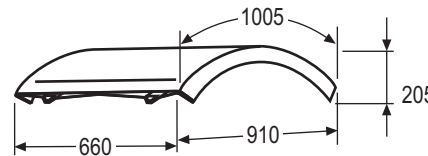

C
641/515
d/s-rh/lh-rechts/links

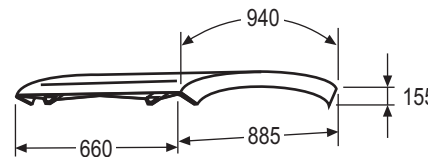

C
641/520
d/s-rh/lh-rechts/links

B
641/510
d/s-rh/lh
rechts/links

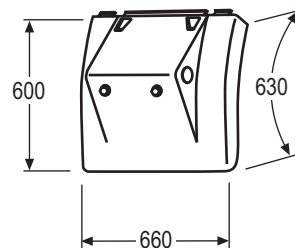

B
641/510
d/s-rh/lh
rechts/links

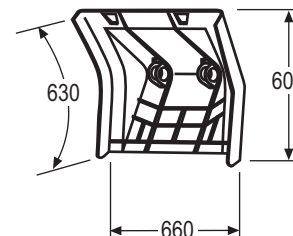

MERCEDES-BENZ MB641 POWERLINER

1820-1826-1827-1831-1834-1935-1935L-1948-2433-2534-2527B-2635-1838-2535

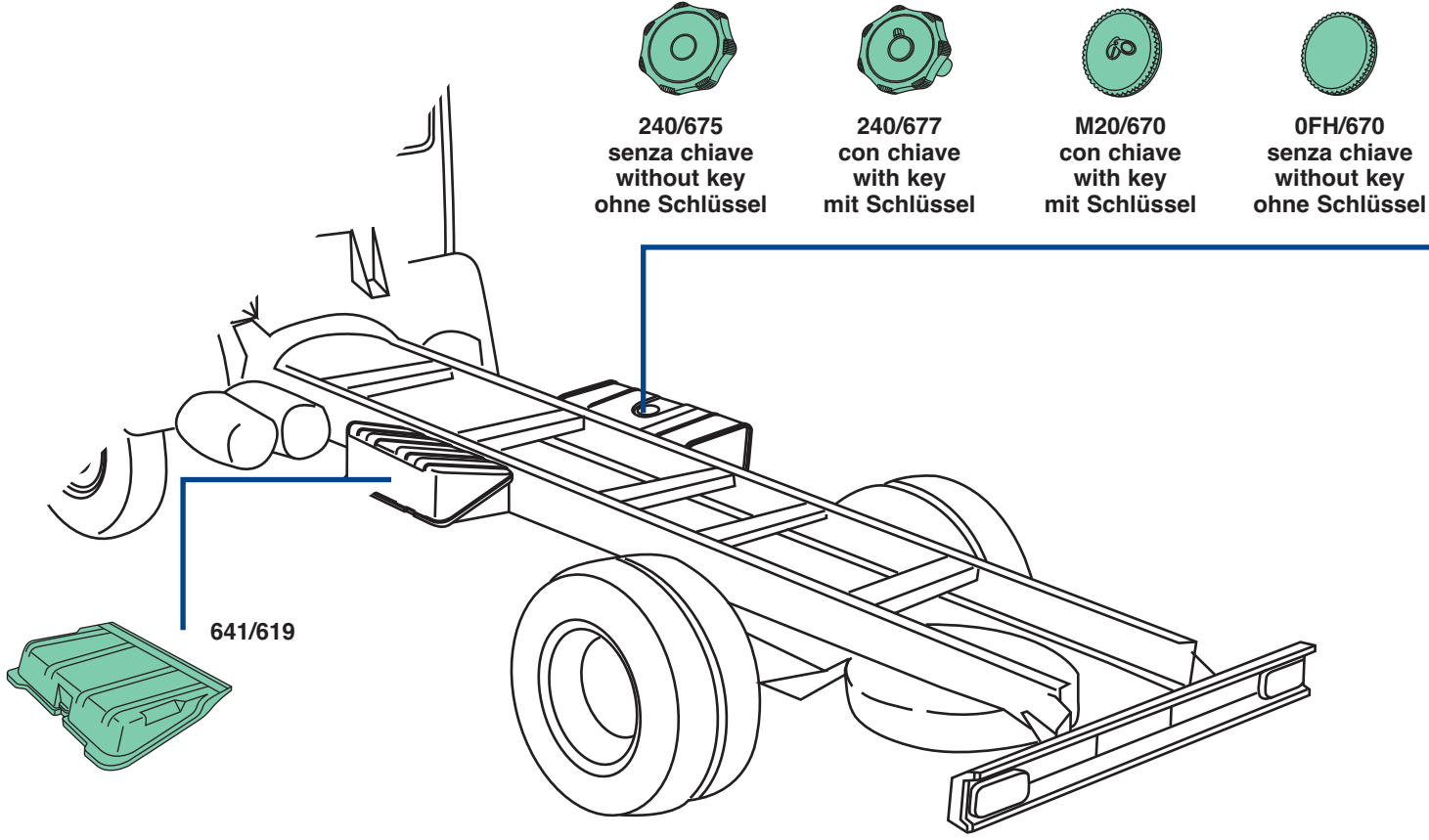

240/675
senza chiave
without key
ohne Schlüssel



240/677
con chiave
with key
mit Schlüssel



M20/670
con chiave
with key
mit Schlüssel



0FH/670
senza chiave
without key
ohne Schlüssel

240/675

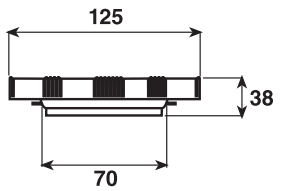

240/677

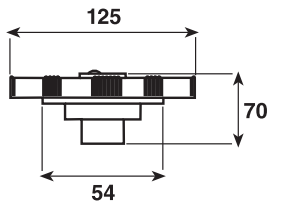

M20/670

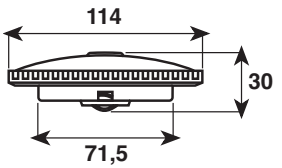

0FH/670

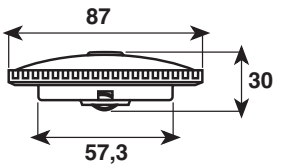

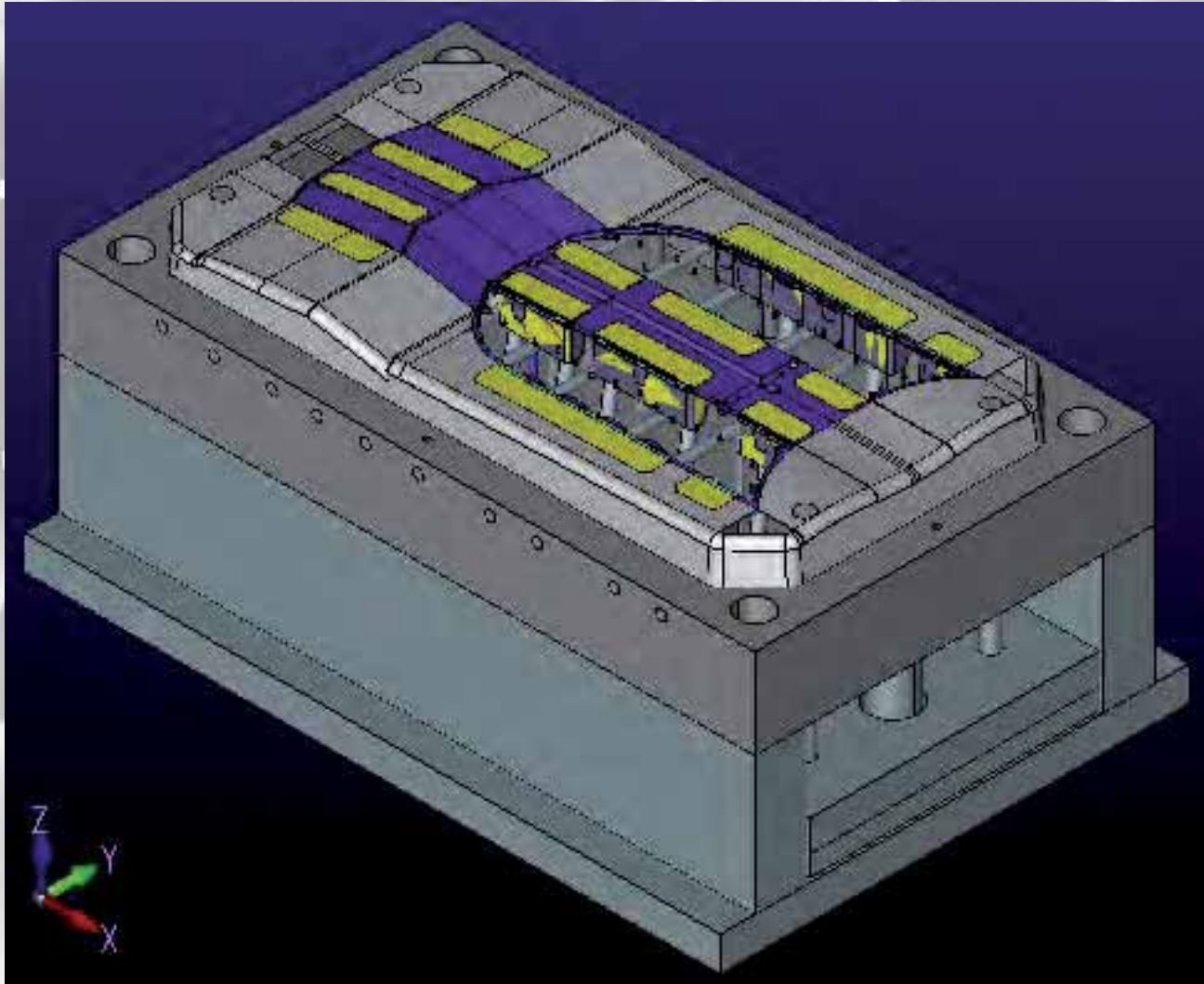

- ▲ IT Progetto in 3D dello stampo ad iniezione per la produzione di griglie
- UK 3-D Project for the mould to be used for the production of grille
- DE 3D-Projekt der Stahlform für die Herstellung von Grill

MERCEDES

MERCEDES-BENZ MB389
1944S-1938

193



381/ 76 d/rh/rechts
381/ 77 s/lh/links



381/ 72 d/rh/rechts
381/ 73 s/lh/links



381/130



381/131

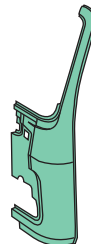

389/815

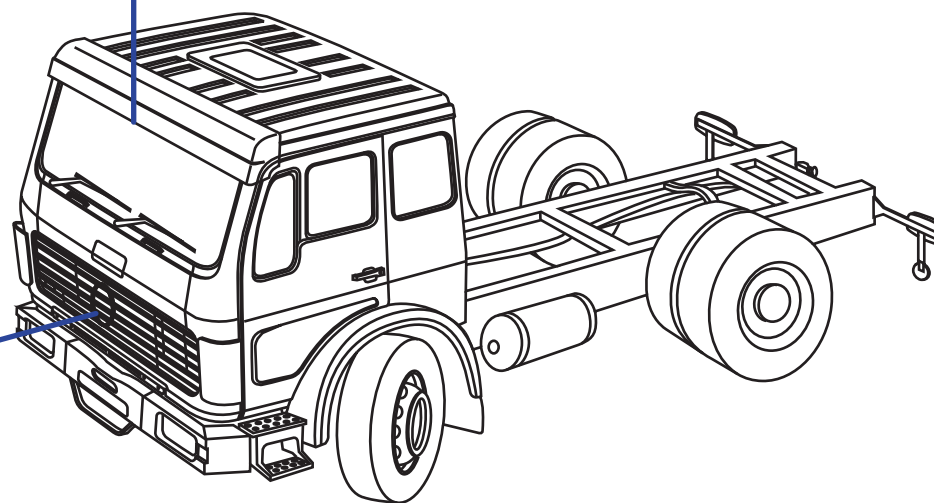
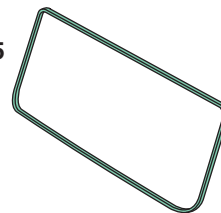

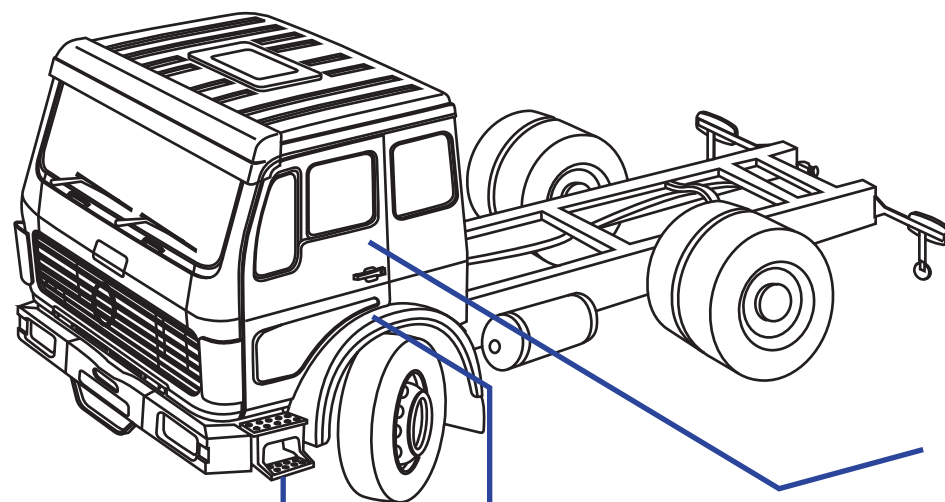

381/216 d/rh/rechts
381/217 s/lh/links

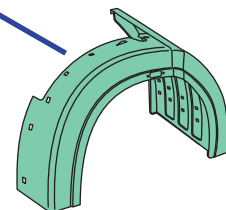
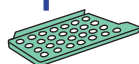

381/200 d/rh/rechts
381/201 s/lh/links

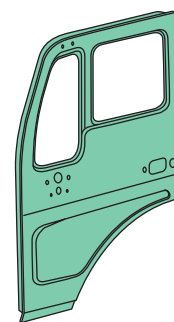

381/ 8 d/rh/rechts
381/ 9 s/lh/links



381/ 10 d/rh/rechts
381/ 11 s/lh/links

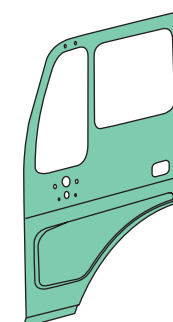

381/ 6 d/rh/rechts
381/ 7 s/lh/links

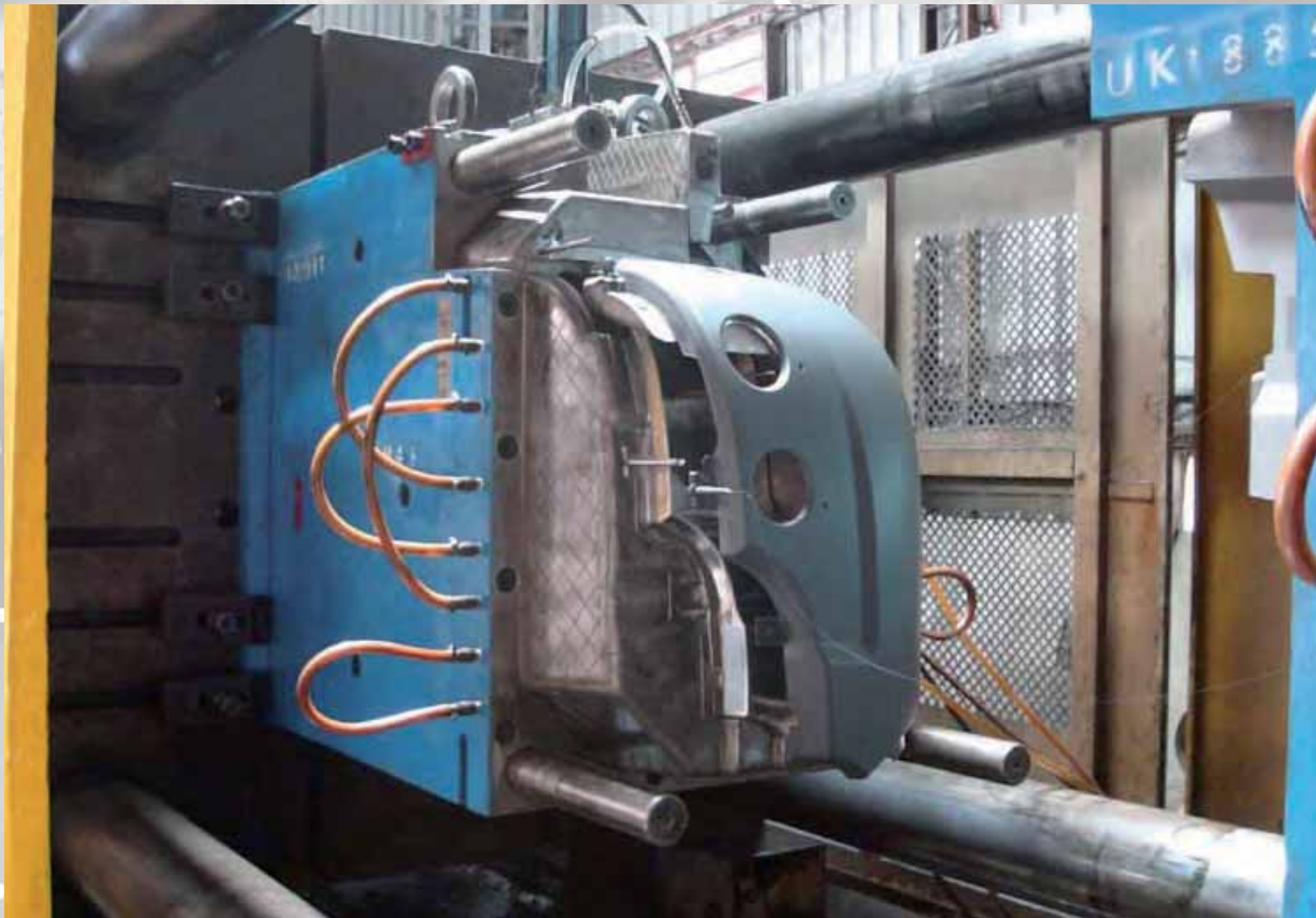

- ▲ IT Stampo ad iniezione per la produzione del cantonale paraurti
- UK Mould to be used for the production of the side bumper
- DE Stahlform für die Herstellung den Stossfängerecke (durch Spritzguss)

MERCEDES

MERCEDES-BENZ MB381

Guida Sinistra / Lh Drive / Linkslenker

1013-1213-1413-1625-1626-1632-1922-1926

1932-1936-1938-2226-2232-2236-2628-2636



197

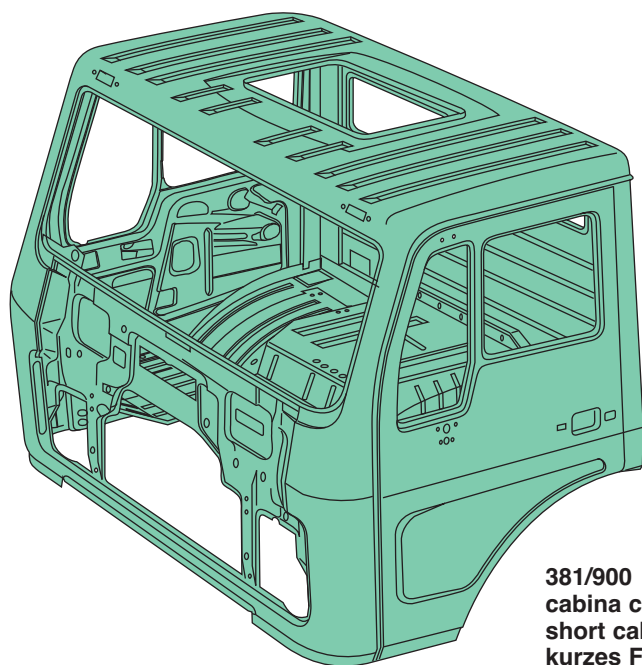

381/900
cabina corta
short cabin
kurzes Fhs.

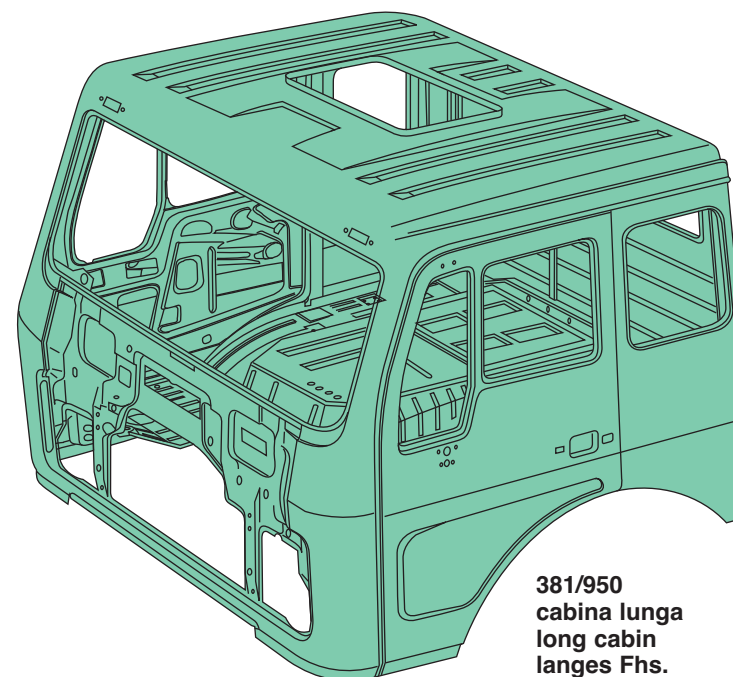

381/950
cabina lunga
long cabin
langes Fhs.

MERCEDES-BENZ MB381
Guida Sinistra / Lh Drive / Linkslenker

1013-1213-1413-1625-1626-1632-1922-1926-1932-1936-1938-2226-2232-2236-2628-2636

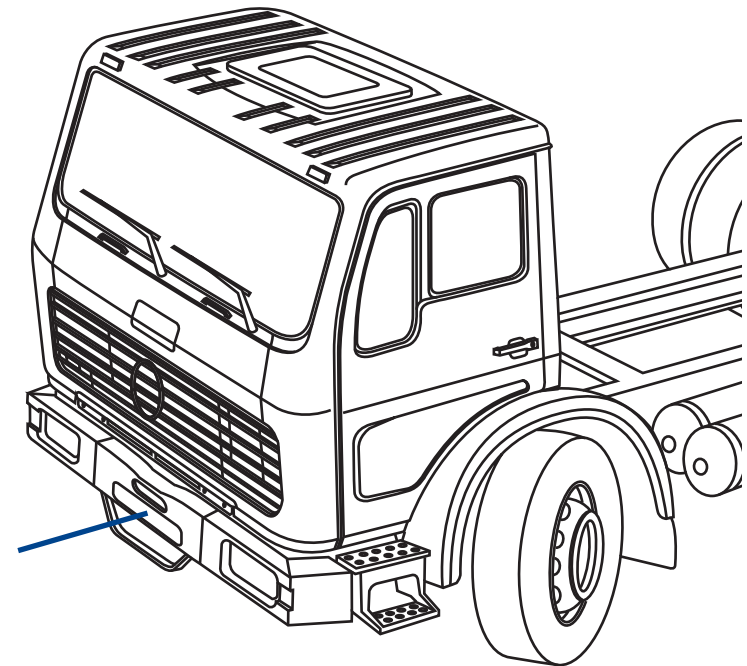
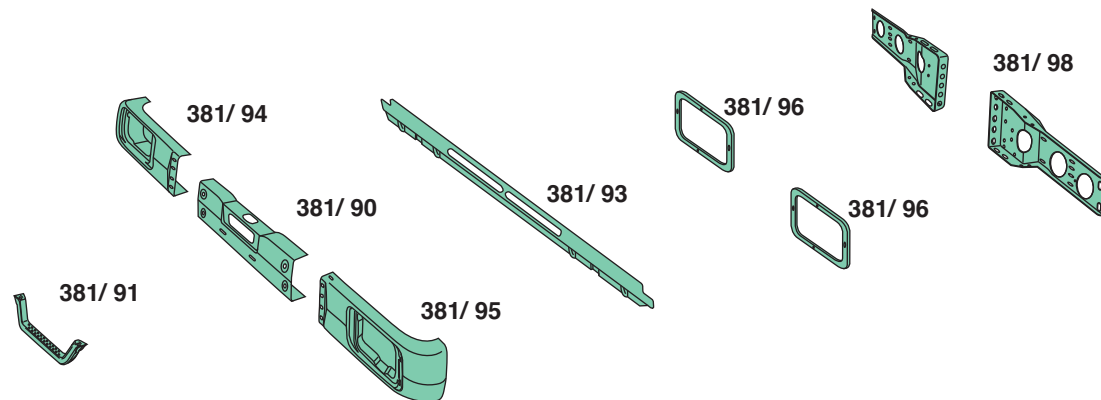

MERCEDES-BENZ MB381
Guida Sinistra / Lh Drive / Linkslenker

1013-1213-1413-1625-1626-1632-1922-1926-1932-1936-1938-2226-2232-2236-2628-2636

200

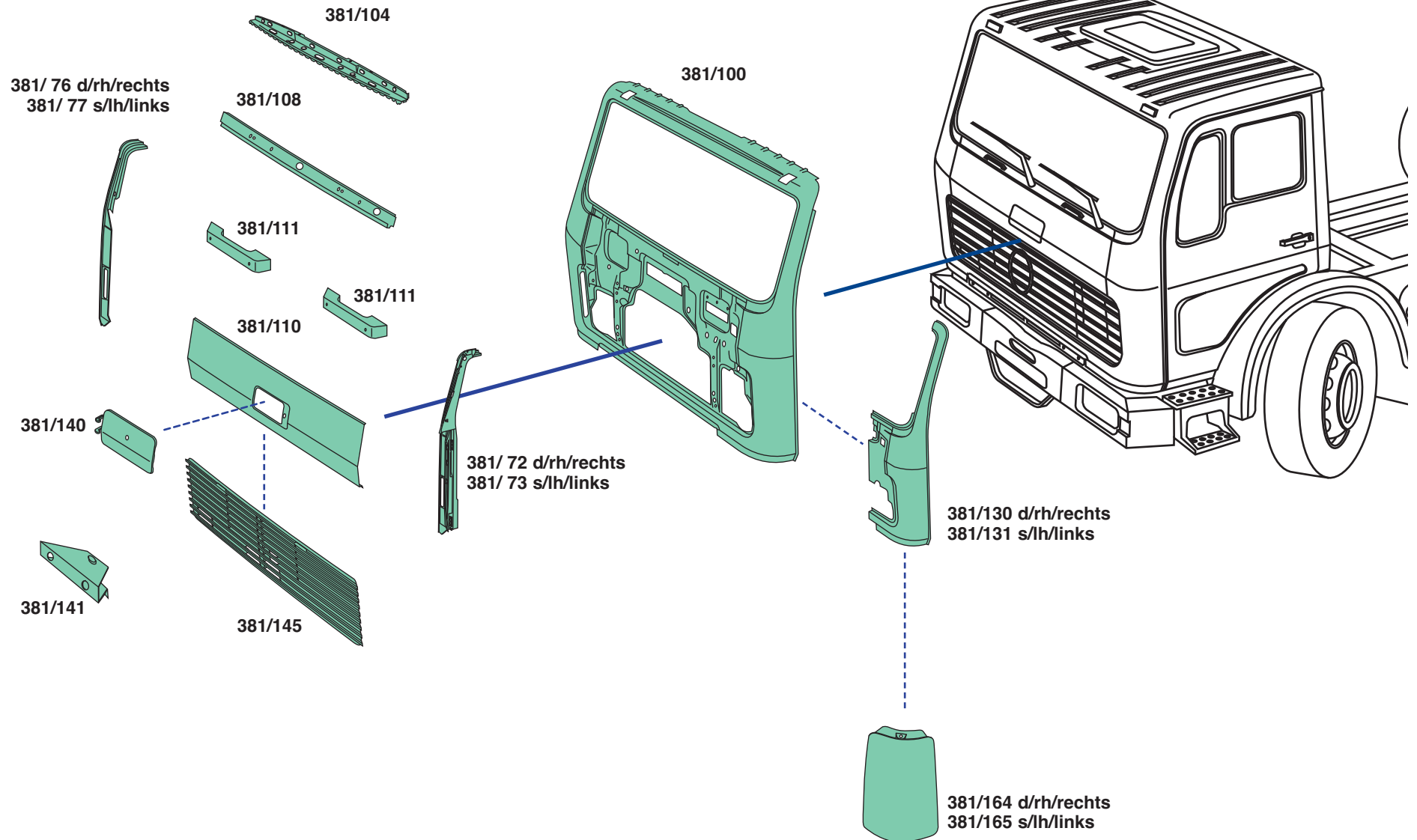

MERCEDES-BENZ MB381
Guida Sinistra / Lh Drive / Linkslenker

1013-1213-1413-1625-1626-1632-1922-1926-1932-1936-1938-2226-2232-2236-2628-2636

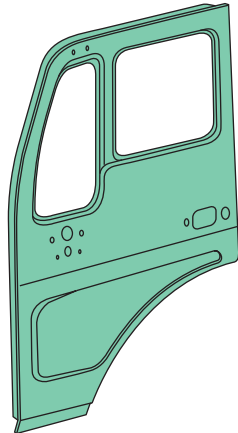
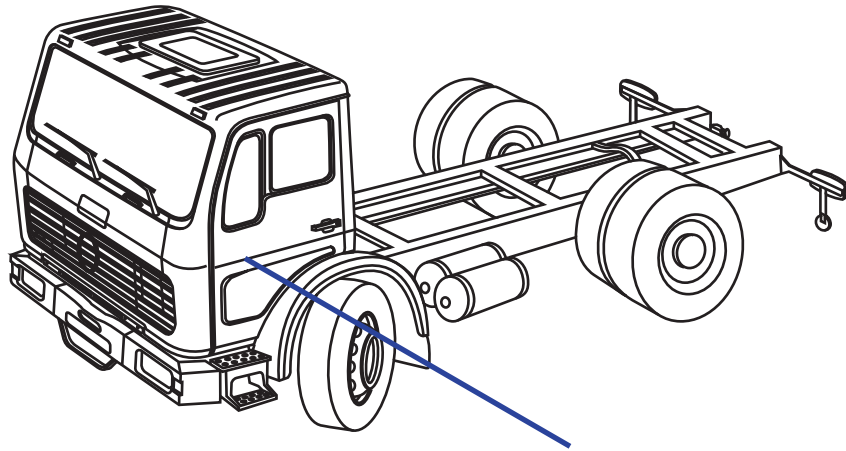

381/ 2 d/rh/rechts
381/ 3 s/lh/links
lastrata 1° serie - c/feritoie
bodywork 1st series – with slits
1. Serie

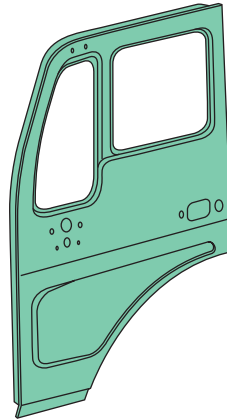

381/ 8 d/rh/rechts
381/ 9 s/lh/links
lastrata 2° serie - c/feritoie
paneled 2nd series – with slots
2. Serie

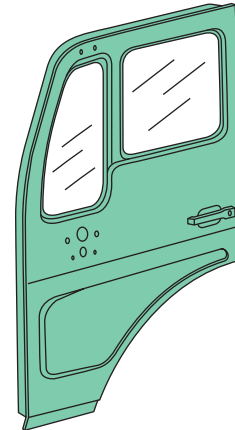

381/ 10 d/rh/rechts
381/ 11 s/lh/links
completa 2° serie
complete door 2nd series
kompl. Tür 2. Serie

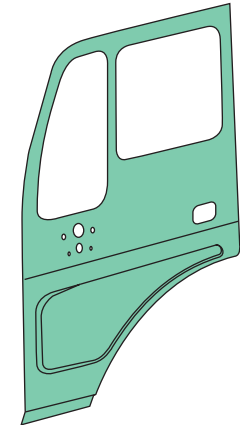

381/ 6 d/rh/rechts
381/ 7 s/lh/links
pannello porta 2° serie
door panel 2nd series
2. Serie

201

202

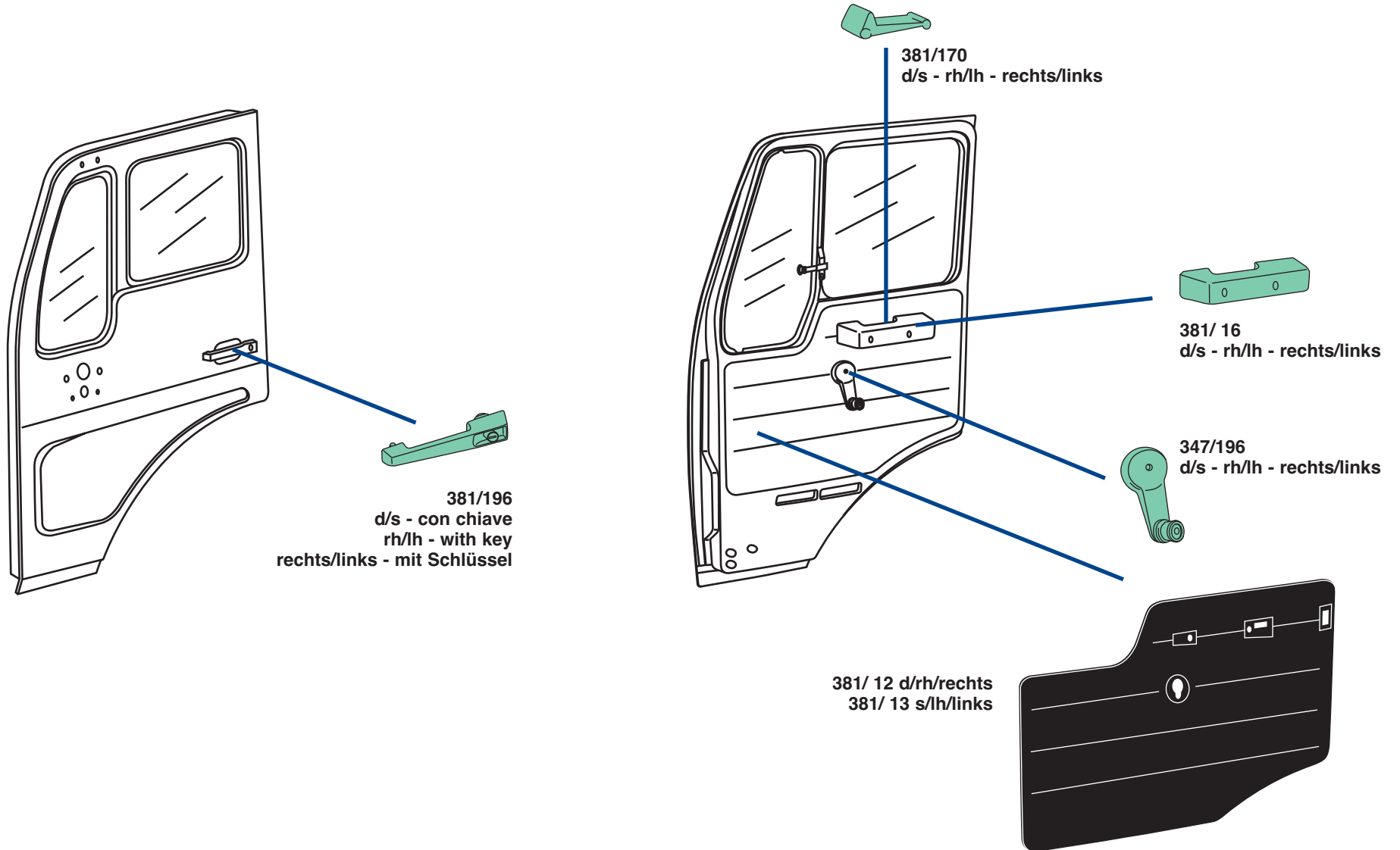

MERCEDES-BENZ MB381
Guida Sinistra / Lh Drive / Linkslenker

1013-1213-1413-1625-1626-1632-1922-1926-1932-1936-1938-2226-2232-2236-2628-2636

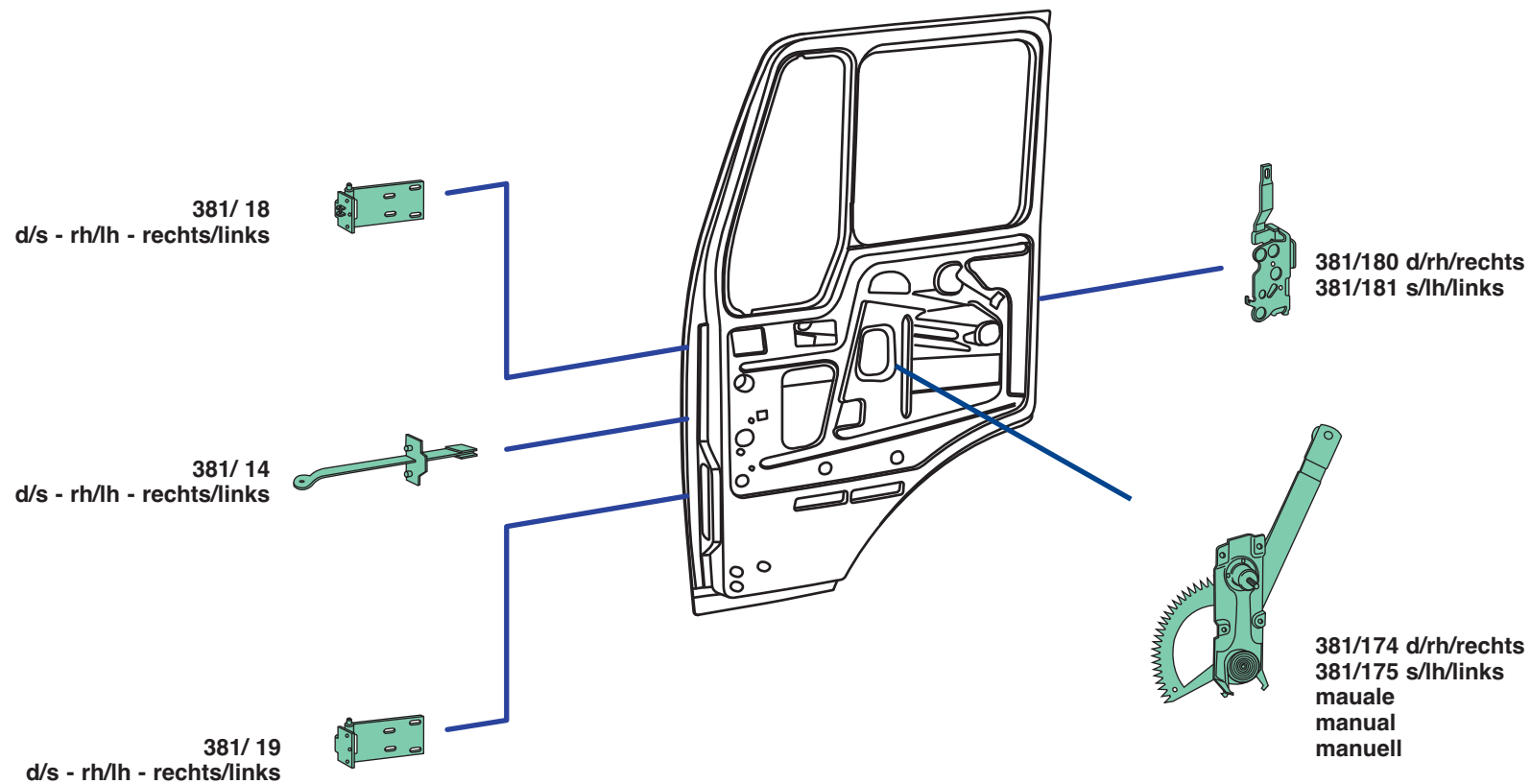

203

MERCEDES-BENZ MB381
Guida Sinistra / Lh Drive / Linkslenker

1013-1213-1413-1625-1626-1632-1922-1926-1932-1936-1938-2226-2232-2236-2628-2636

(*) Versione Cava-Cantiere
Yard & Quarry version
Baustellenfahrzeug

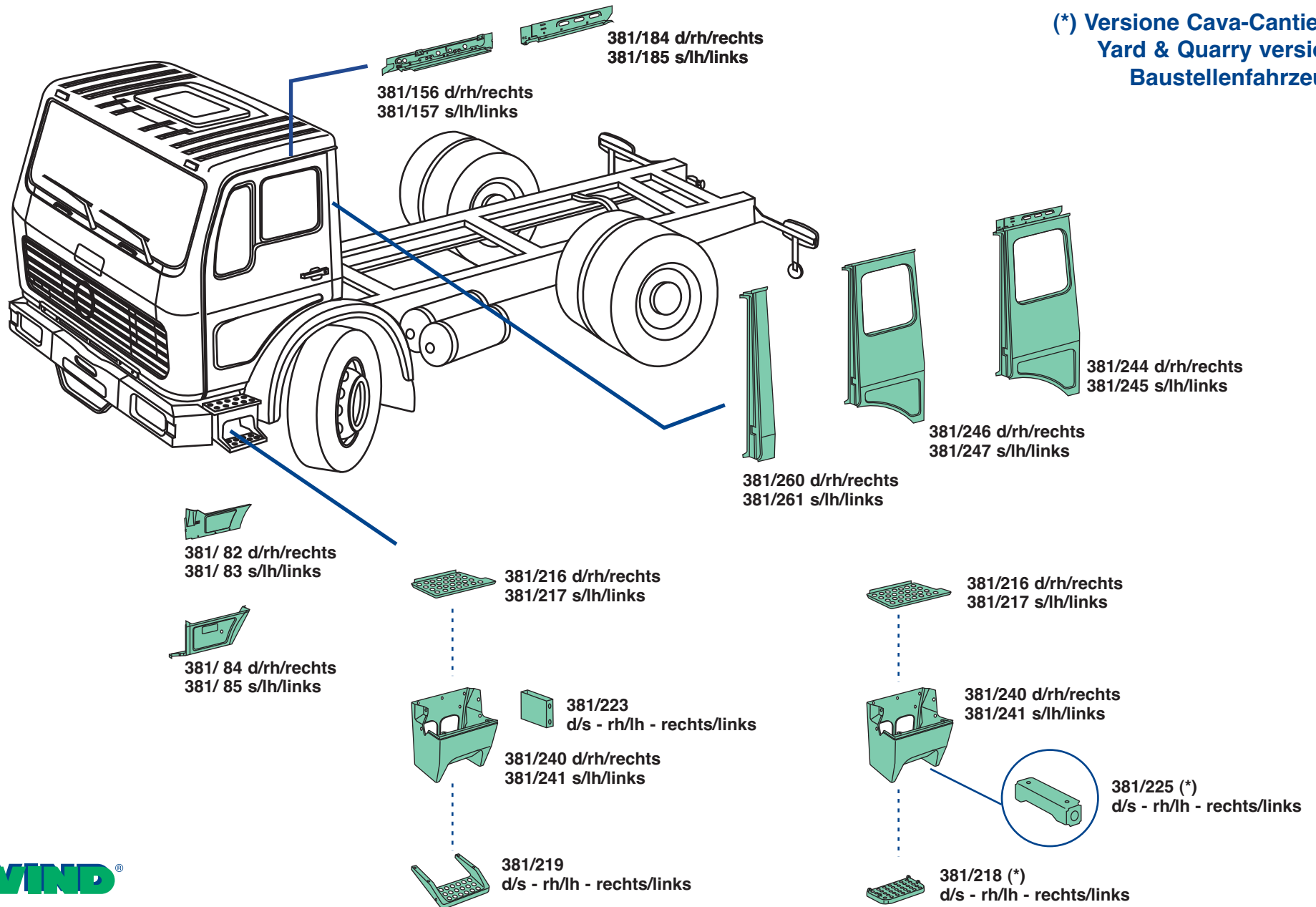

1013-1213-1413-1625-1626-1632-1922-1926-1932-1936-1938-2226-2232-2236-2628-2636

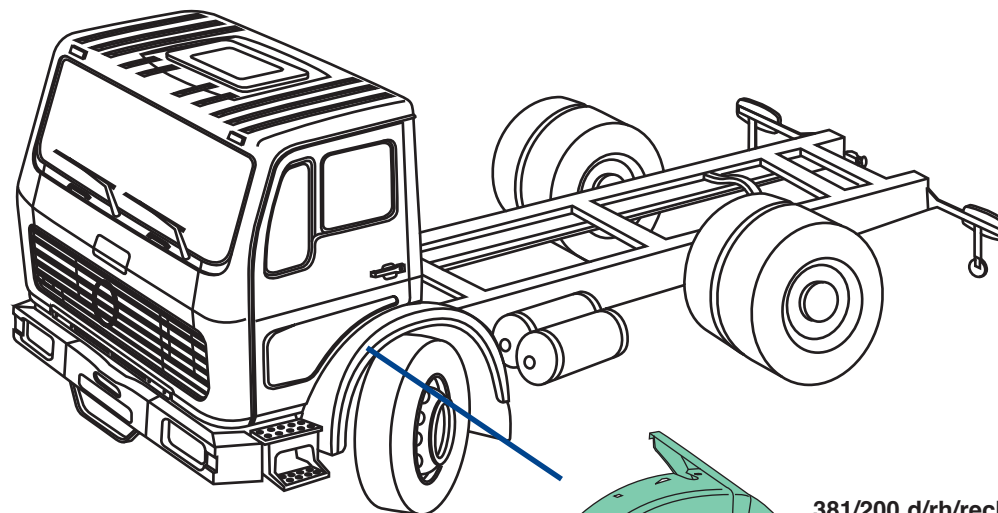

205

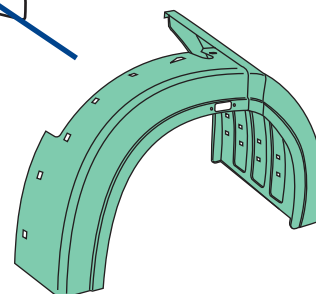

381/200 d/rh/rechts
381/201 s/lh/links

381/314 d/rh/rechts
381/315 s/lh/links

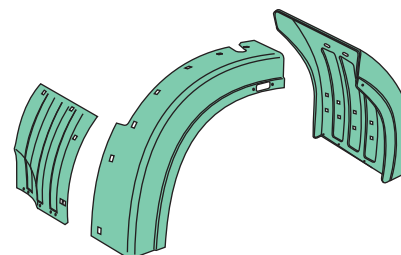

381/320 d/rh/rechts
381/321 s/lh/links

381/204 d/rh/rechts
381/205 s/lh/links

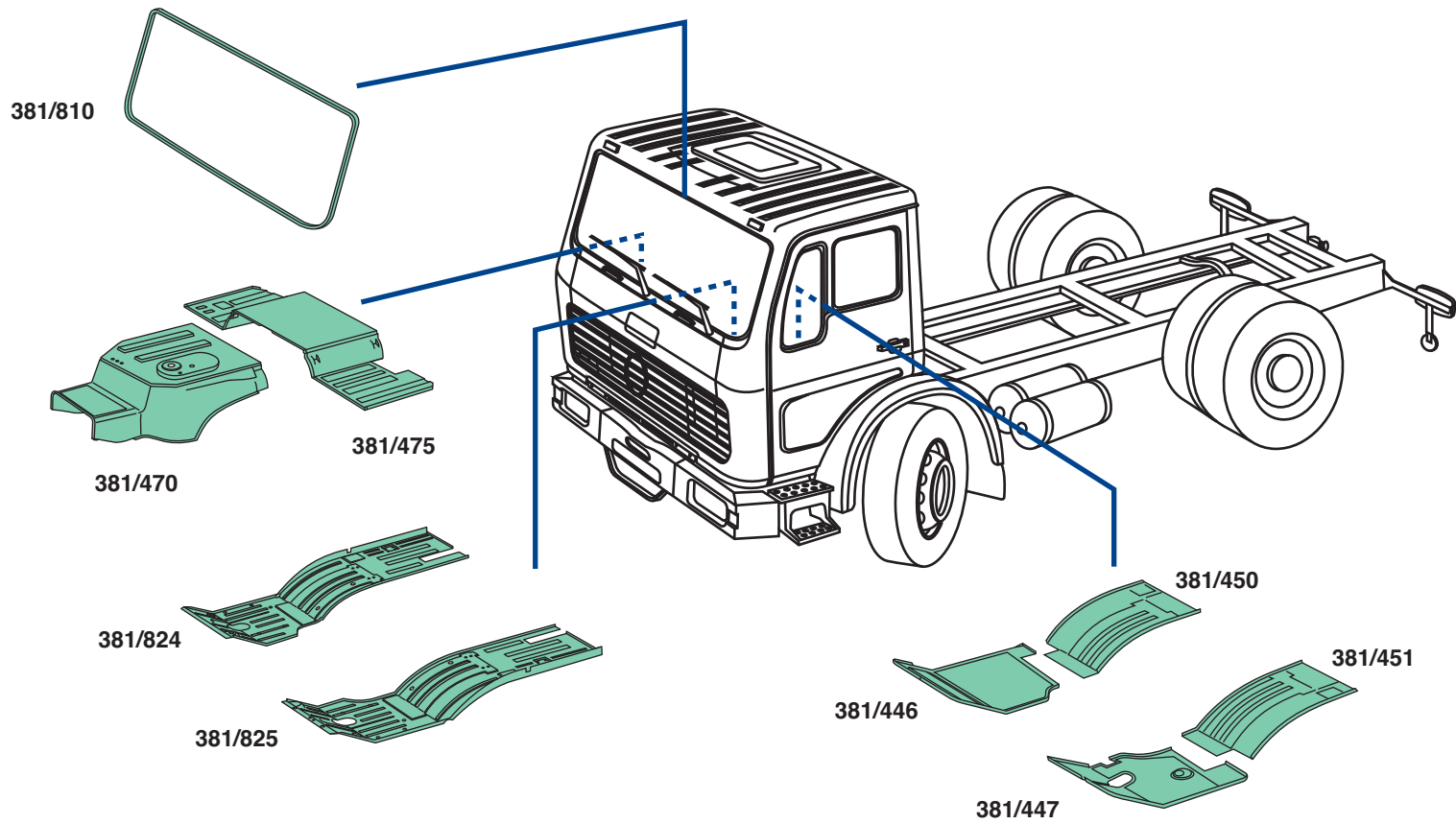

1013-1213-1413-1625-1626-1632-1922-1926-1932-1936-1938-2226-2232-2236-2628-2636

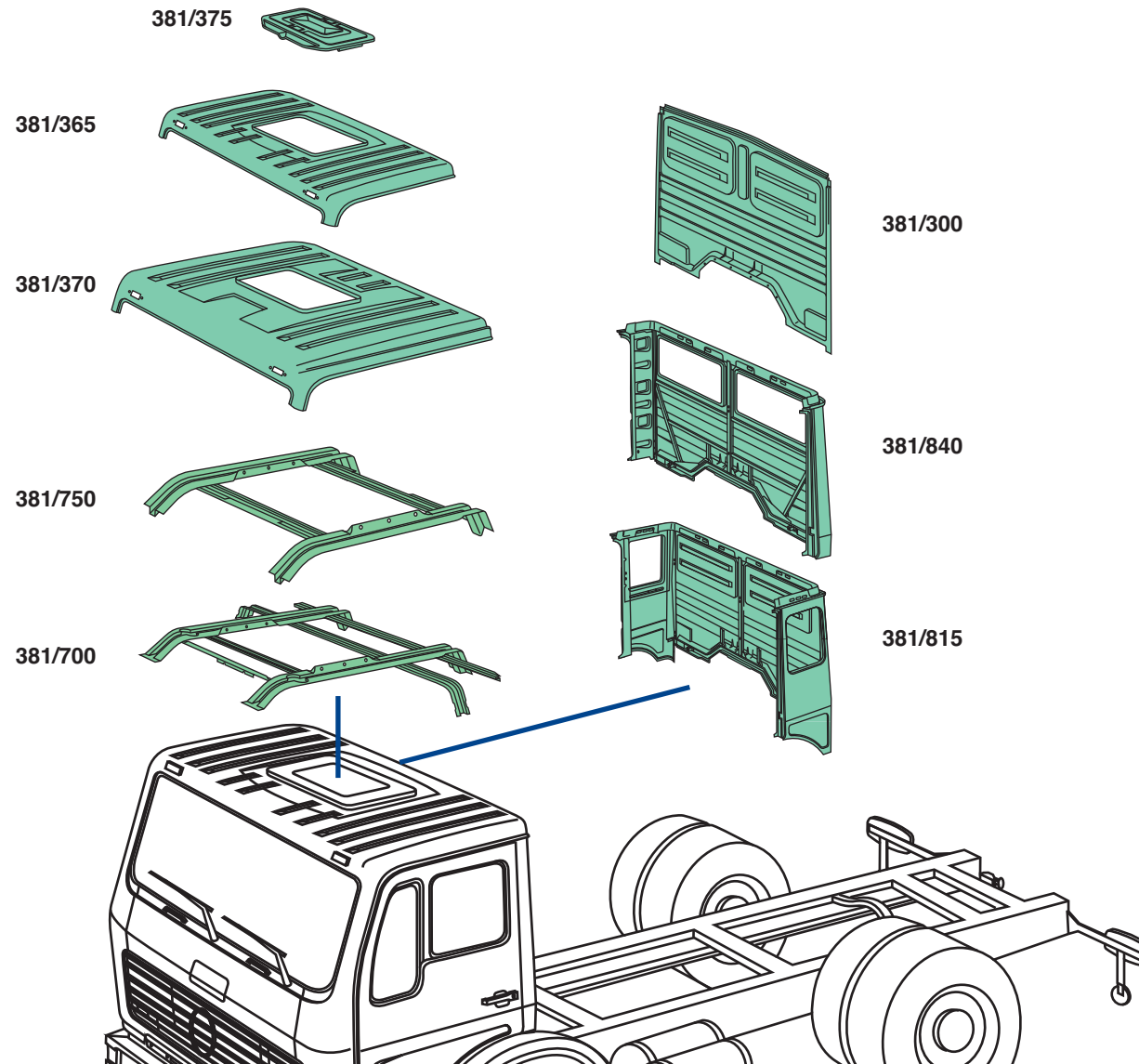

MERCEDES-BENZ MB381
Guida Sinistra / Lh Drive / Linkslenker

1013-1213-1413-1625-1626-1632-1922-1926-1932-1936-1938-2226-2232-2236-2628-2636

240/675

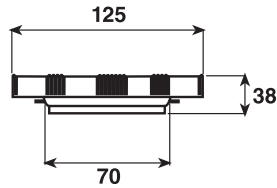

240/677

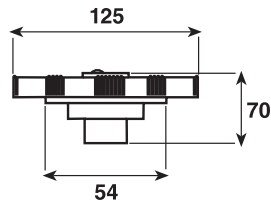

M20/670

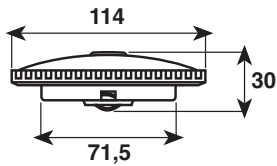

0FH/670

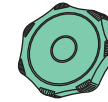
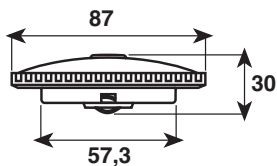

240/675
senza chiave
without key
ohne Schlüssel



240/677
con chiave
with key
mit Schlüssel



M20/670
con chiave
with key
mit Schlüssel



0FH/670
senza chiave
without key
ohne Schlüssel

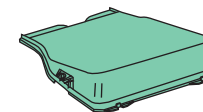
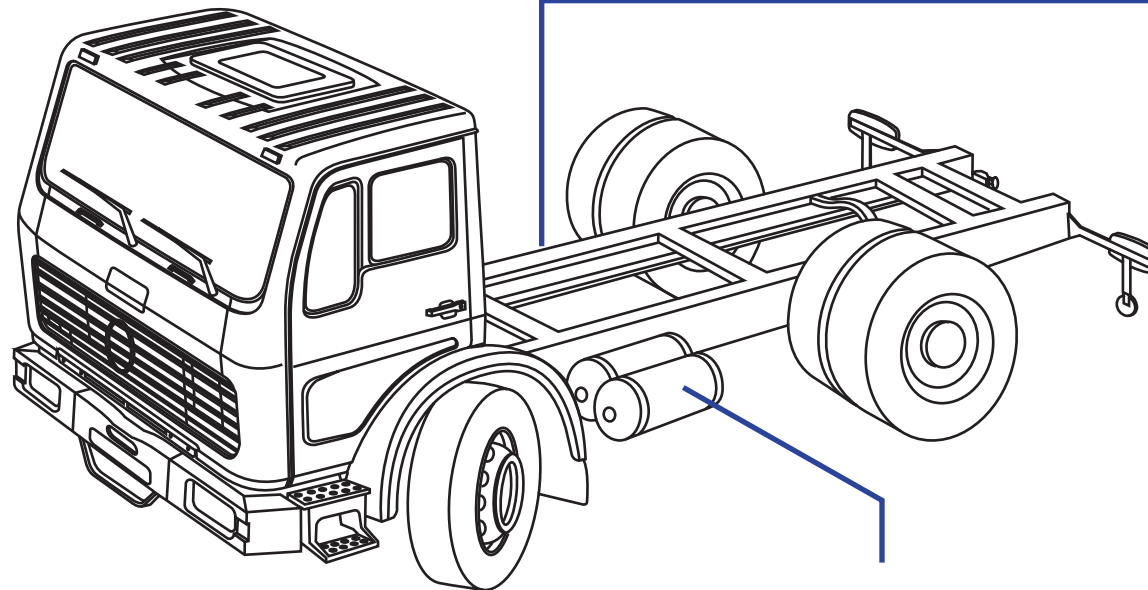

381/619

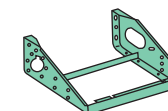

381/620

MERCEDES

MERCEDES-BENZ MB381

Guida Destra / Rh Drive / Recht Lenker

1013-1213-1413-1625-1626-1632-1922-192

1932-1936-1938-2226-2232-2236-2628-2636



209

MERCEDES-BENZ MB381

Guida Destra / Rh Drive / Rechtslenker

1013-1213-1413-1625-1626-1632-1922-1926-1932-1936-1938-2226-2232-2236-2628-2636

210

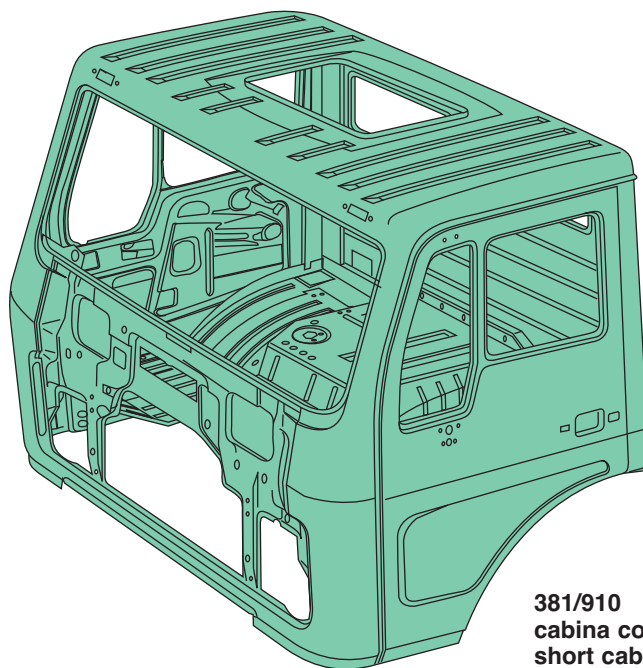

381/910
cabina corta
short cabin
kurzes Fhs.

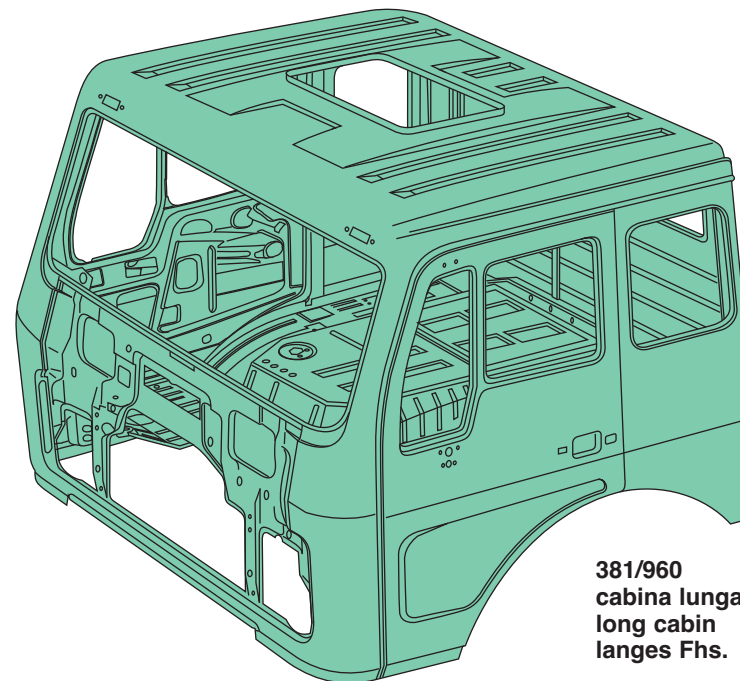

381/960
cabina lunga
long cabin
langes Fhs.

1013-1213-1413-1625-1626-1632-1922-1926-1932-1936-1938-2226-2232-2236-2628-2636

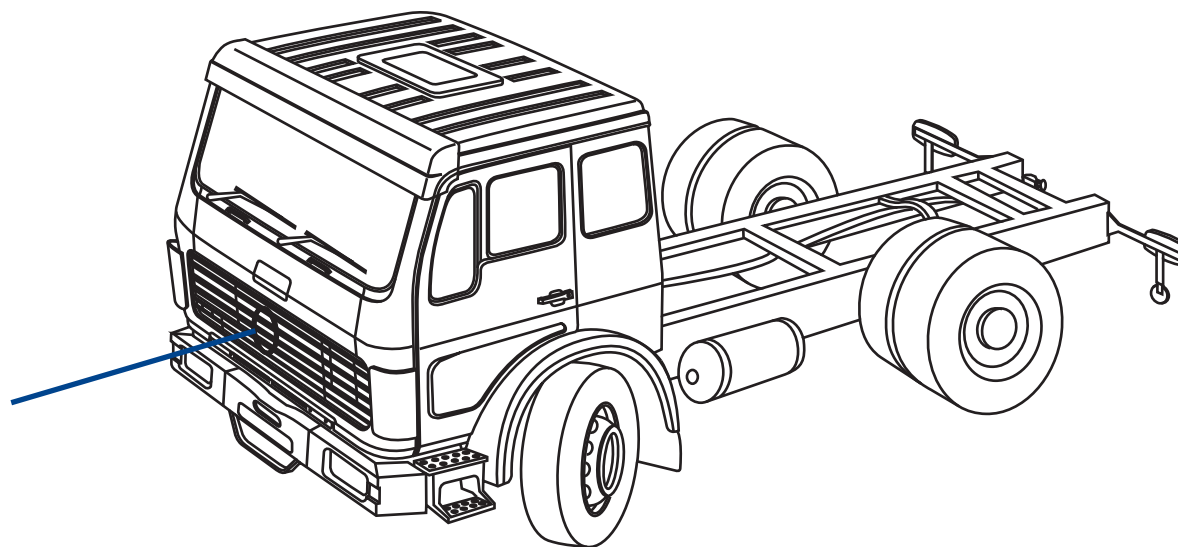
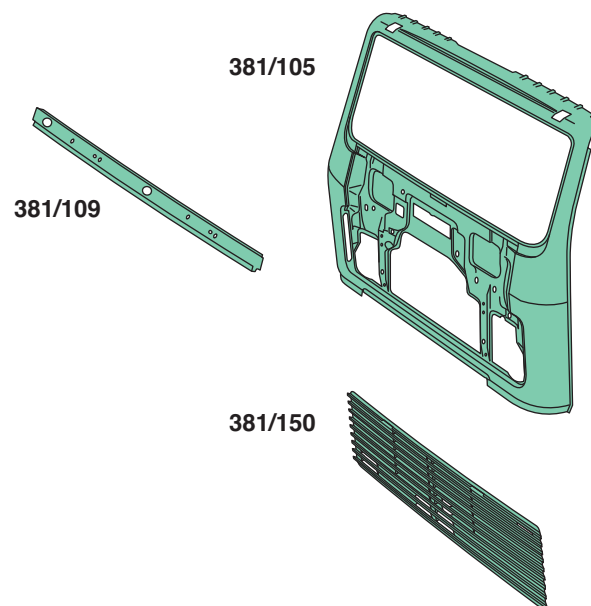

1013-1213-1413-1625-1626-1632-1922-1926-1932-1936-1938-2226-2232-2236-2628-2636

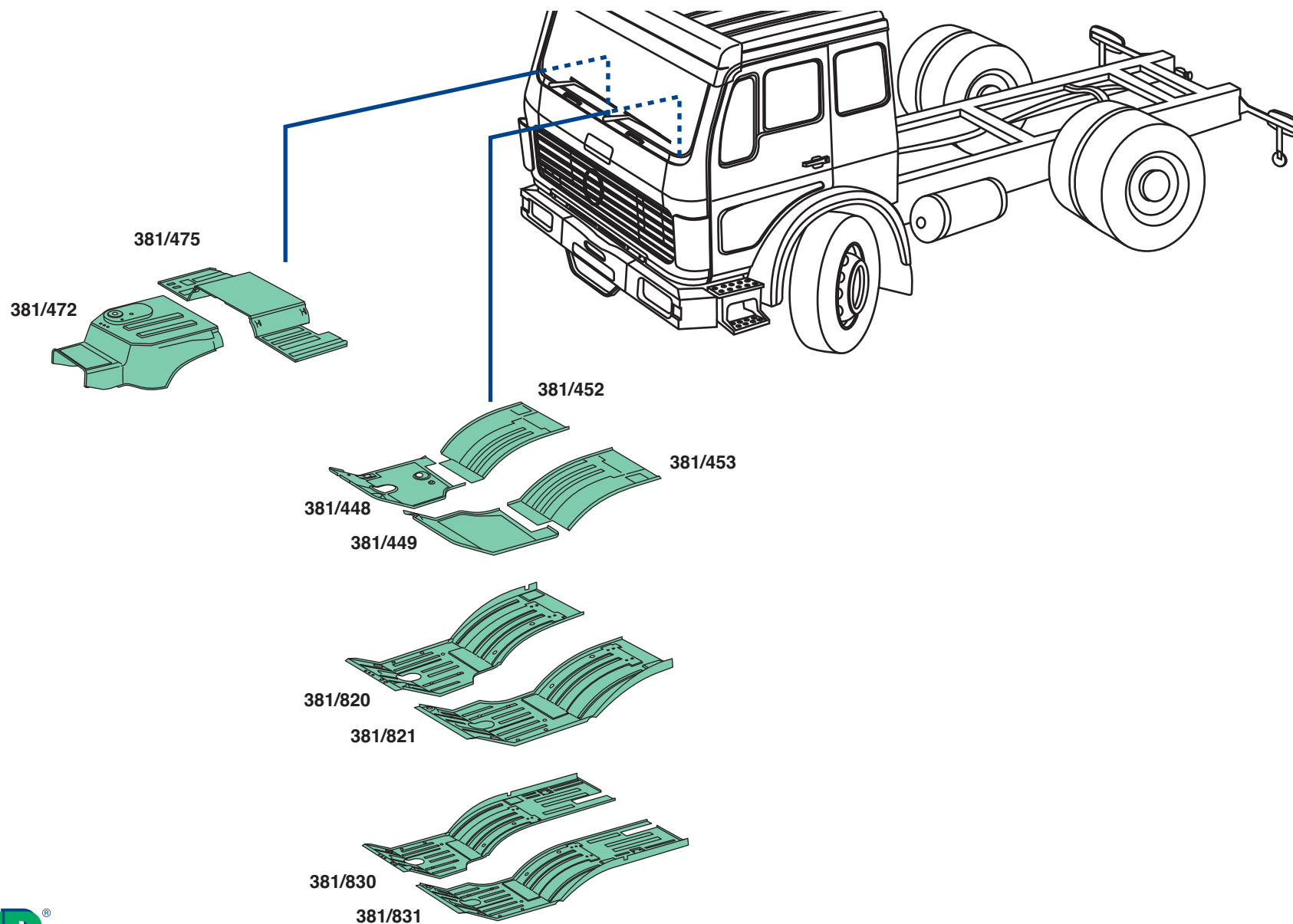

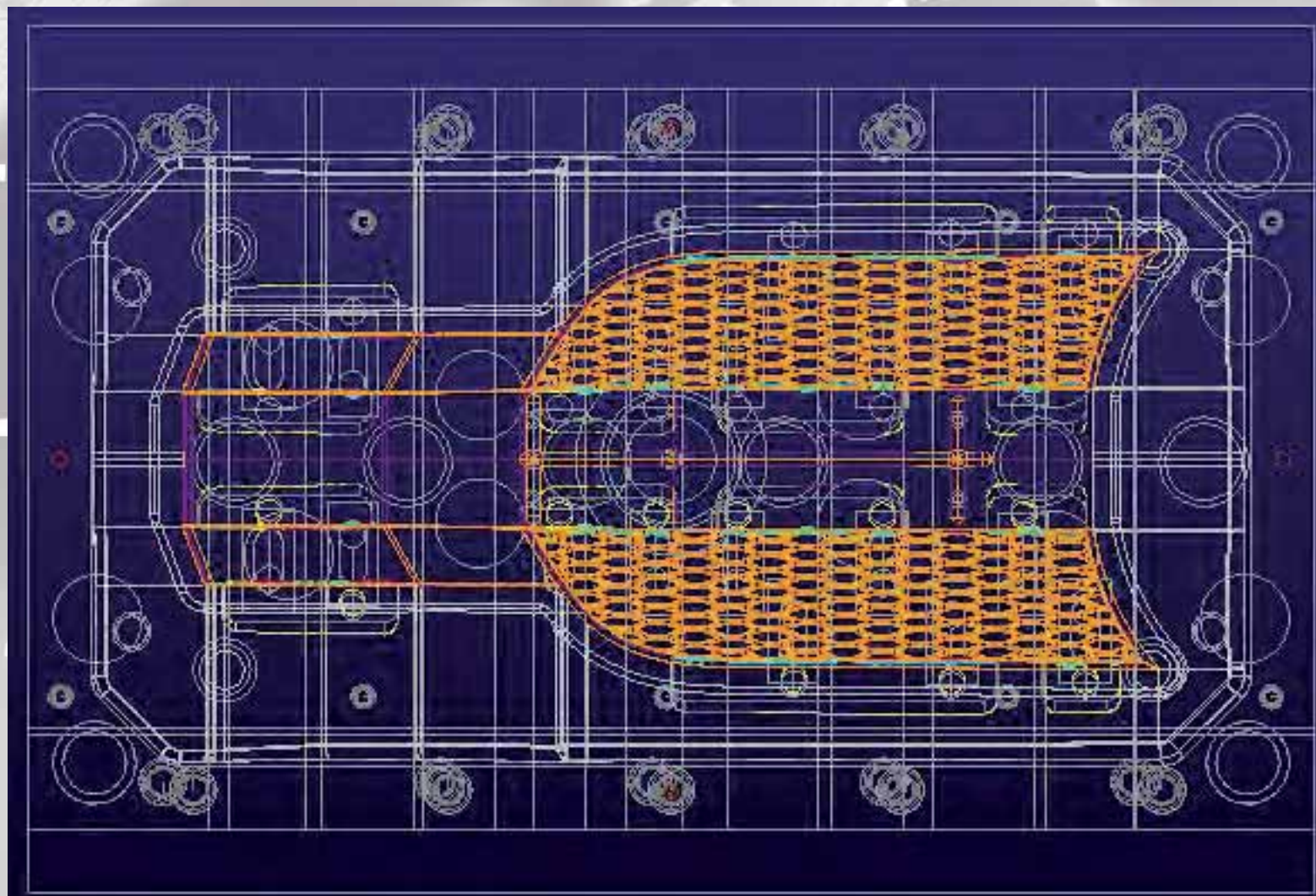

▲ IT Progetto in 3D dello stampo ad iniezione per la produzione di griglie

UK 3-D Project for the mould to be used for the production of grille

DE 3D-Projekt der Stahlform für die Herstellung von Grill



- ▲ IT Stand fieristico in un salone nel Nord Europa
- UK Exhibition pavillon for an exhibition in Northern Europe
- DE Messestand für Nordeuropa

MERCEDES

MERCEDES-BENZ 347

**347-334-1218-1618-1620-1623-1624-1920
1921-1923-1924-2220-2620-2623-2624**

215



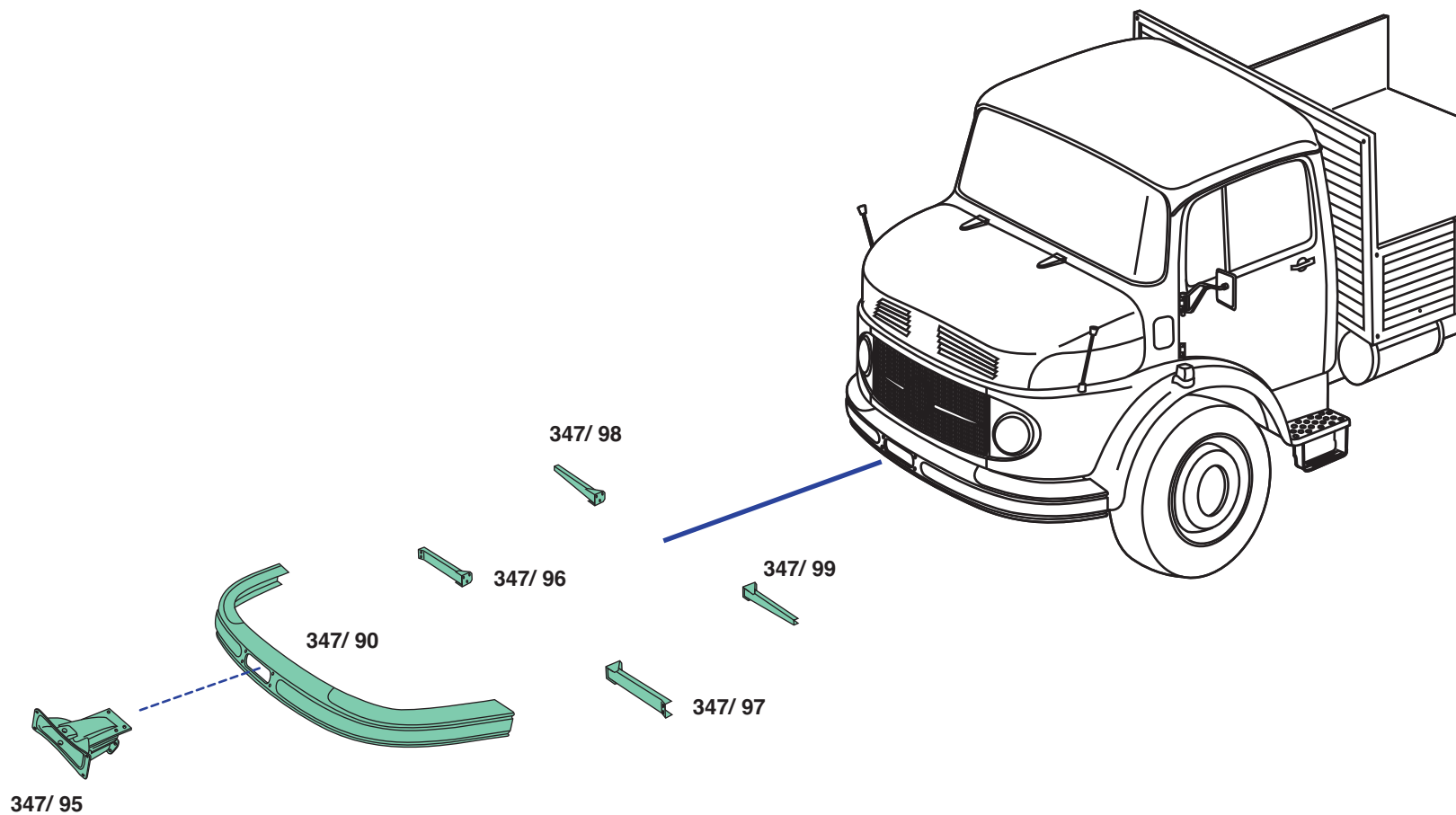

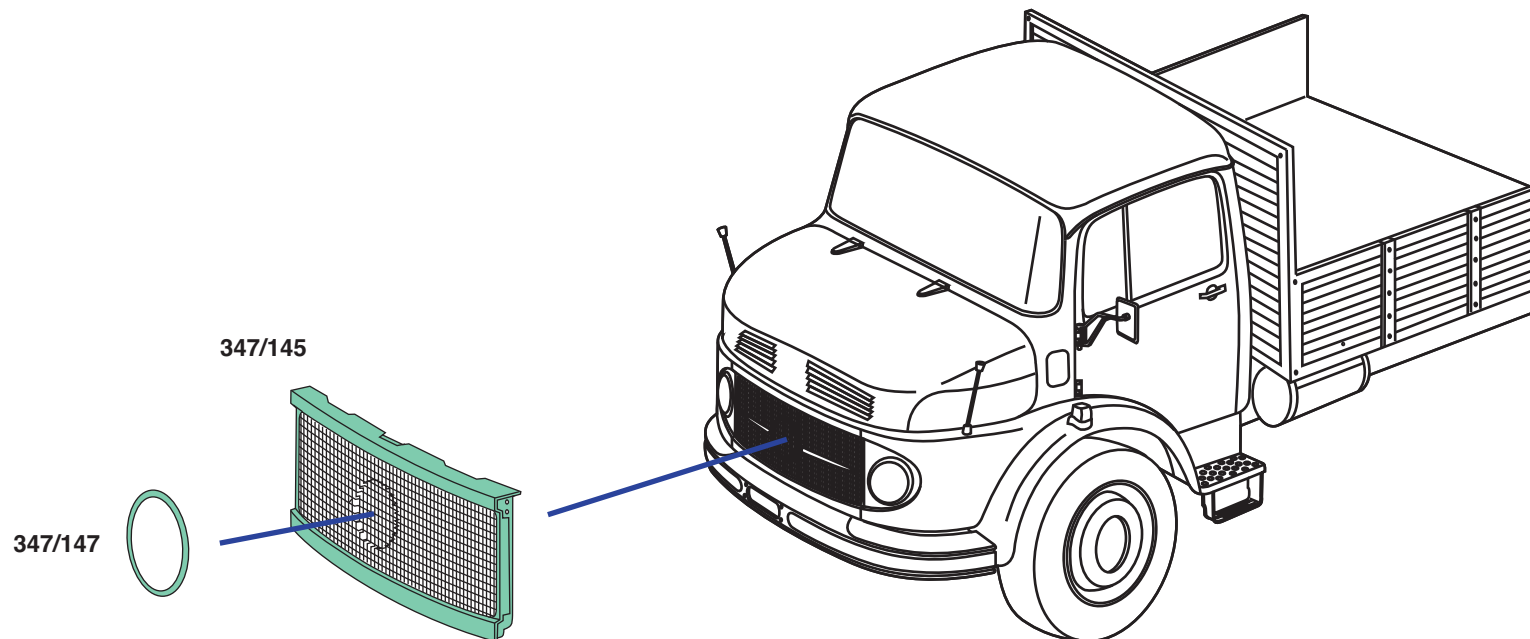

347/133 d/rh/rechts

347/134 s/lh/links

347/135
Turbo

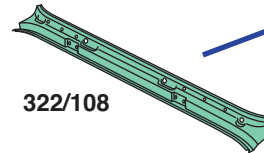
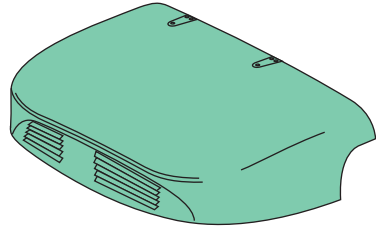

322/108

347/140

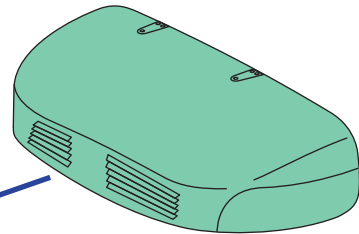

347/141

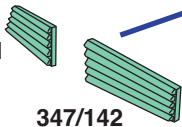

347/142

347/136

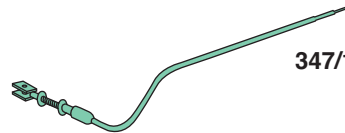

347/138



347/139



347/137

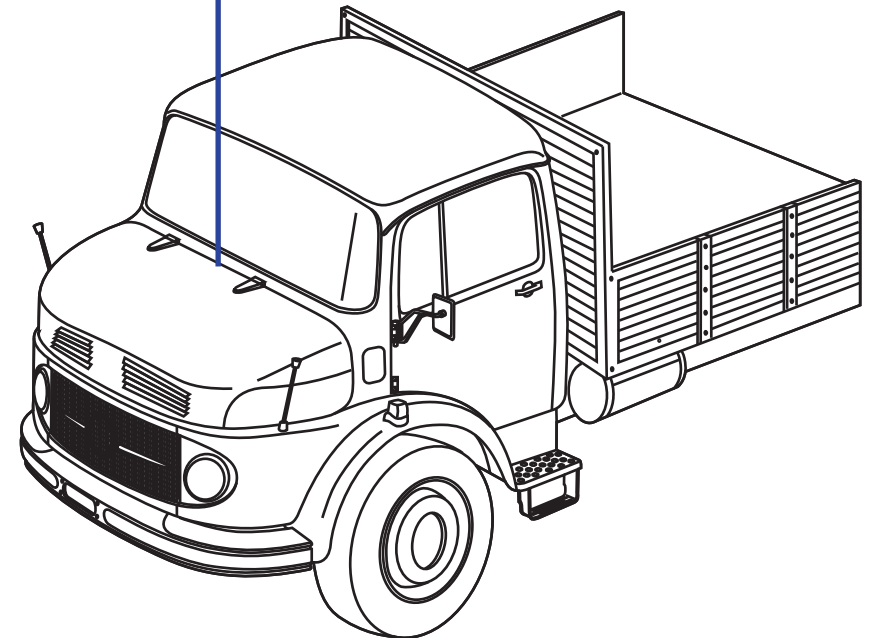

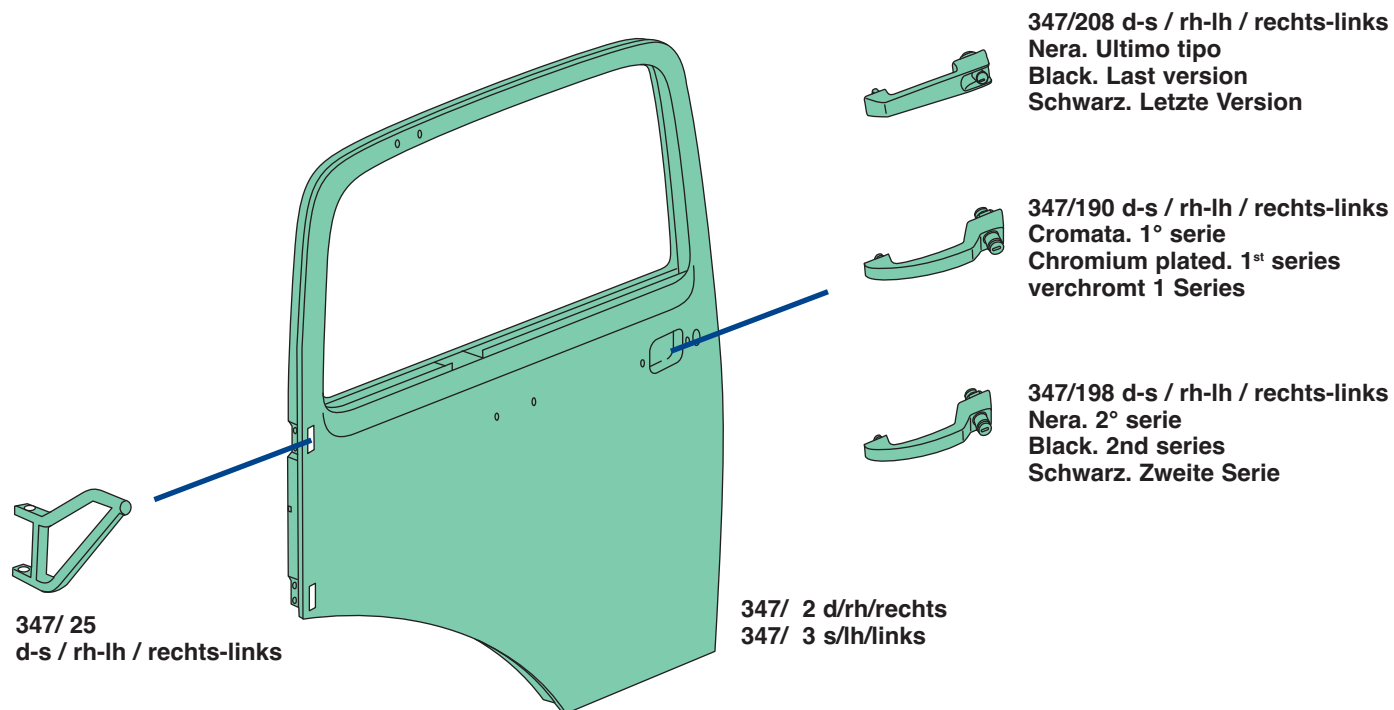

220

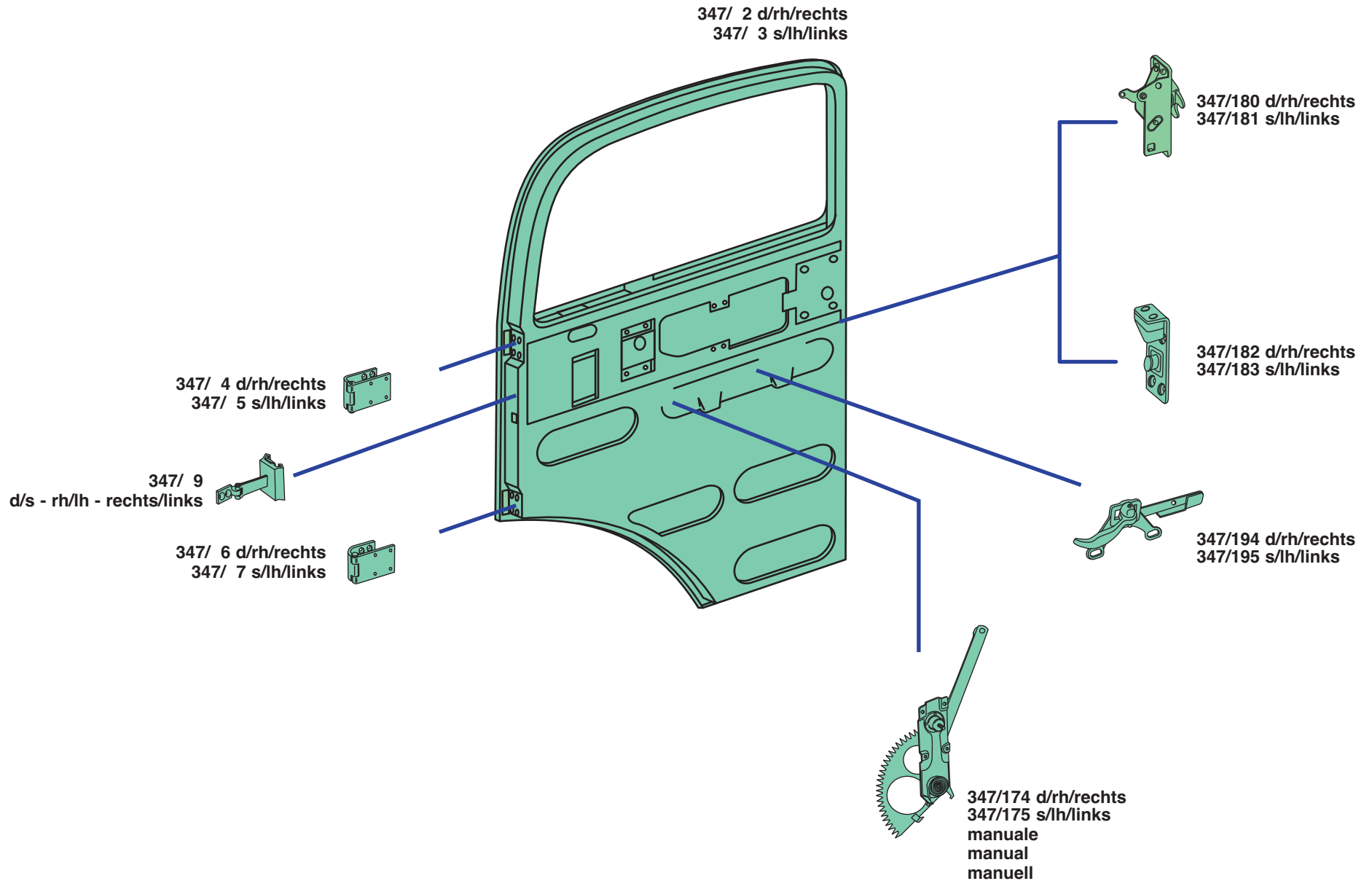

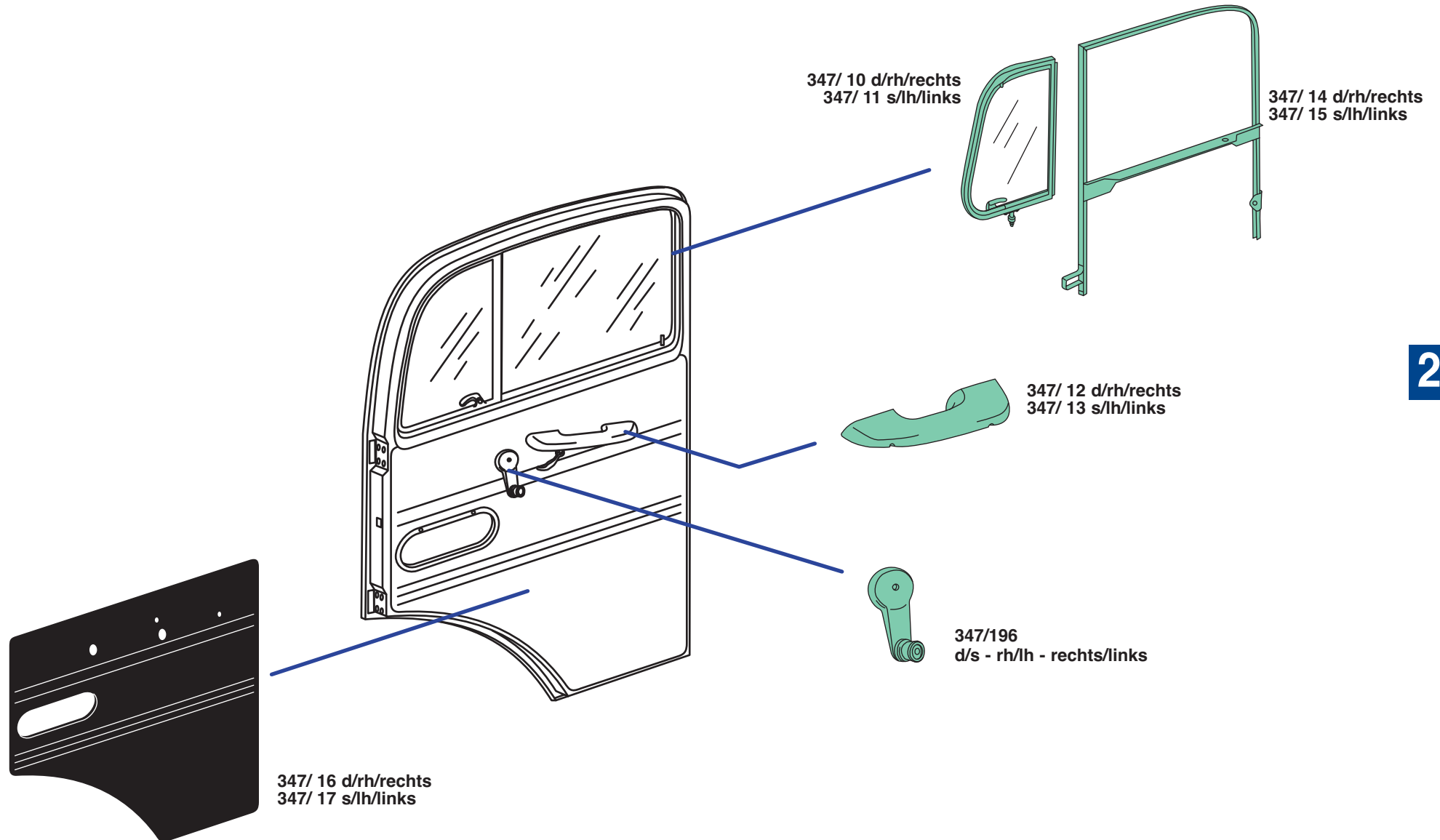

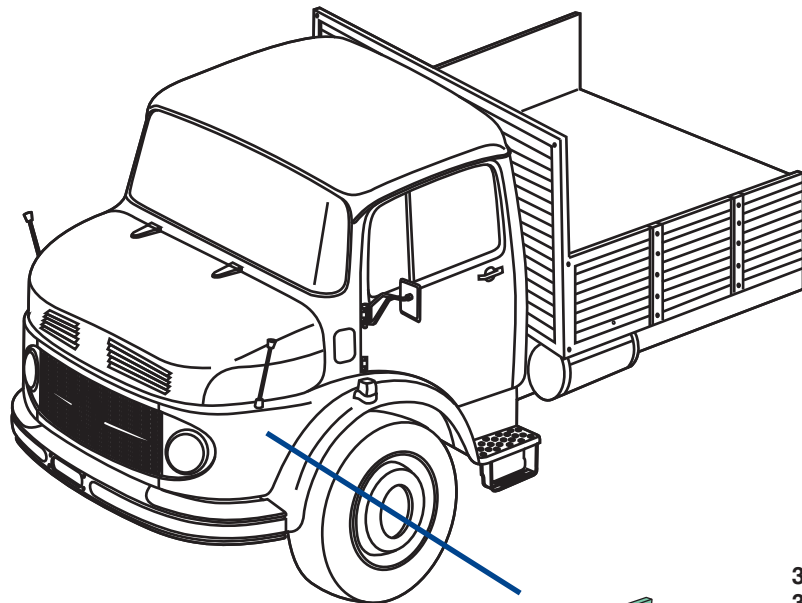

222

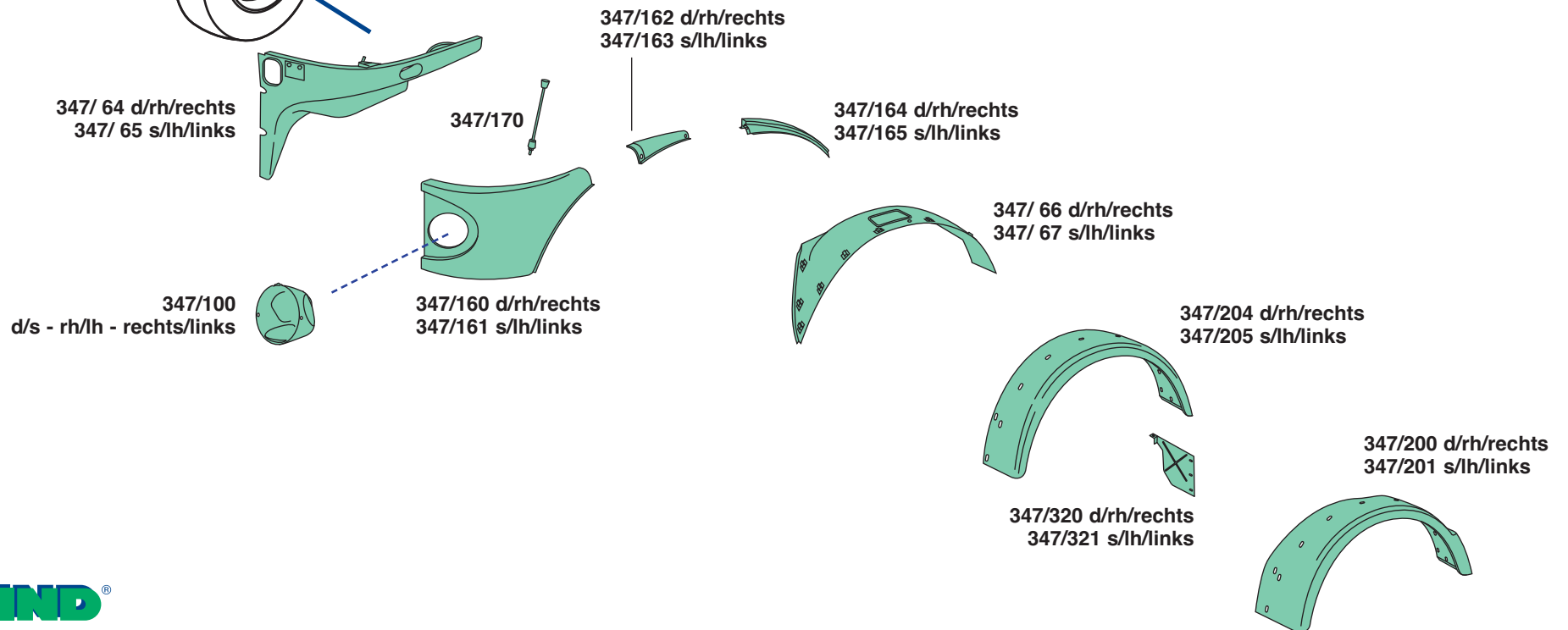

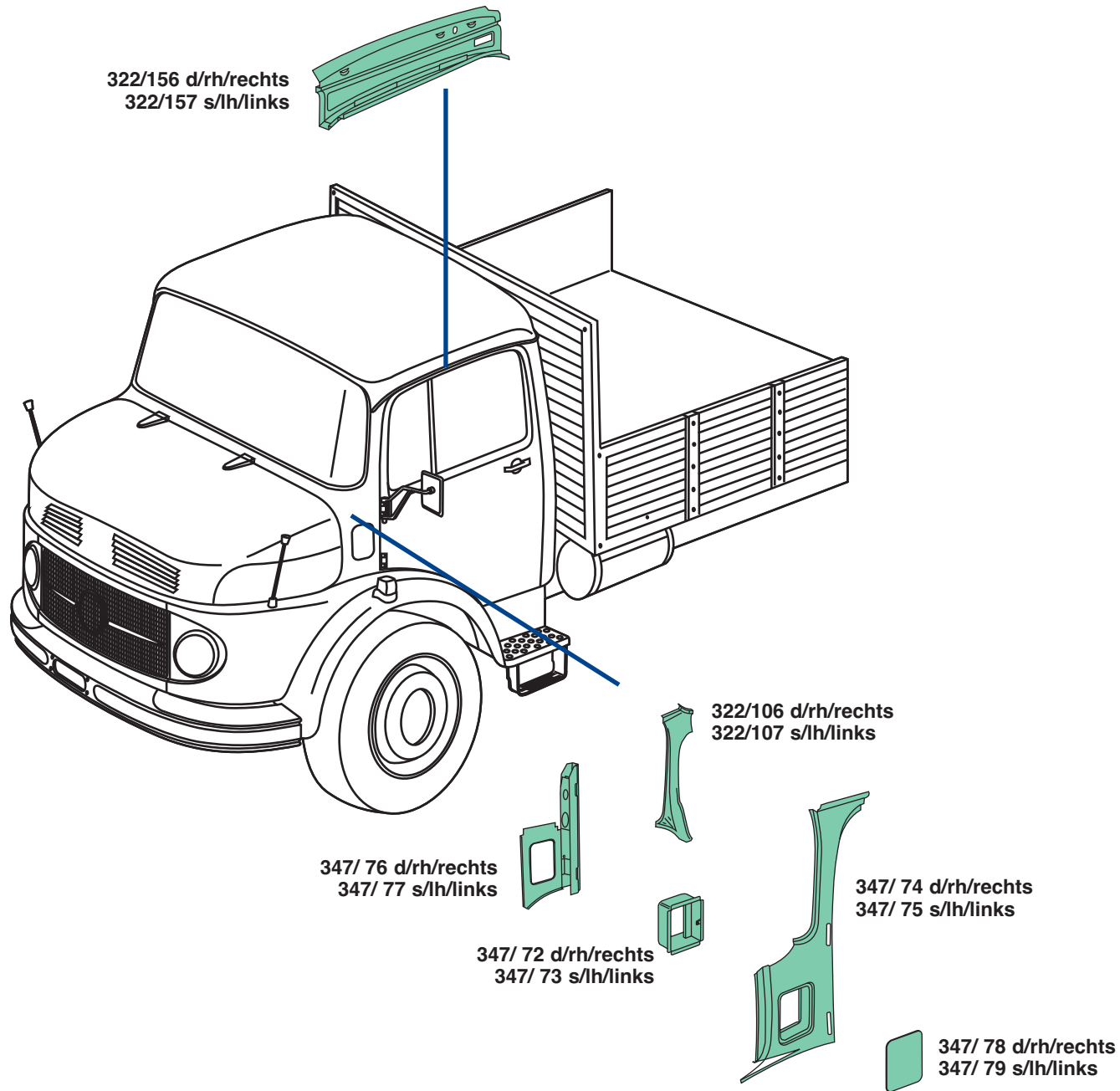

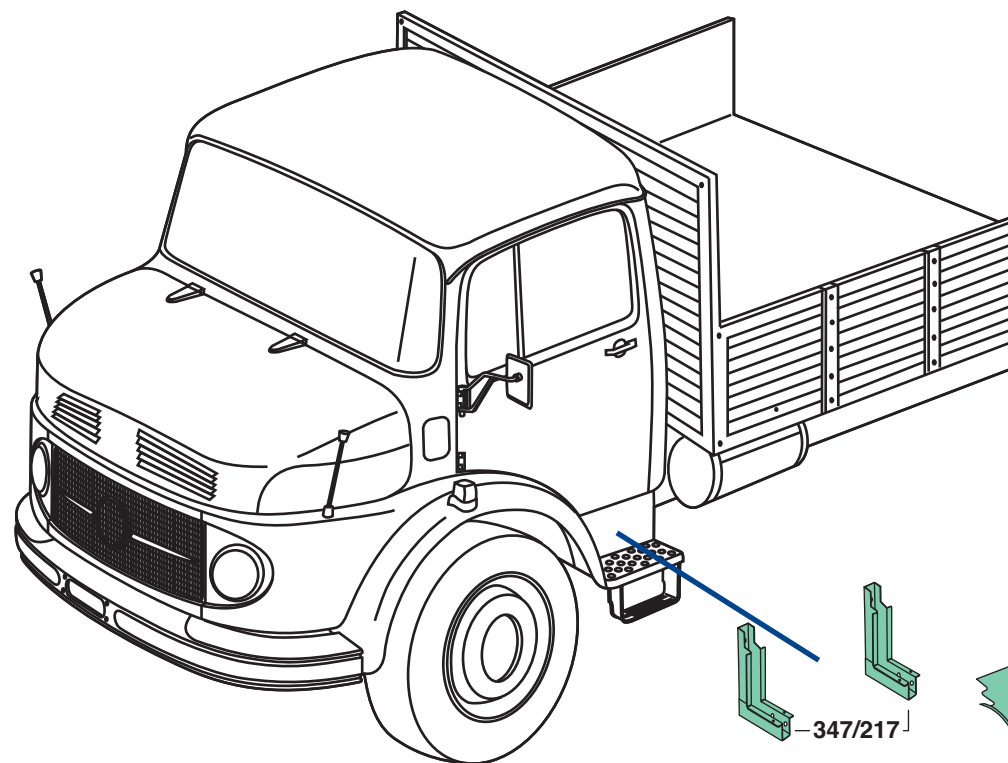

224

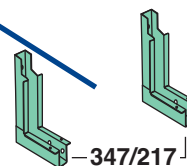

347/217

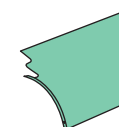

347/230 d/rh/rechts
347/231 s/lh/links

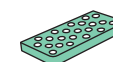

347/212 d/rh/rechts
347/213 s/lh/links



347/215
d/s - rh/lh - rechts/links

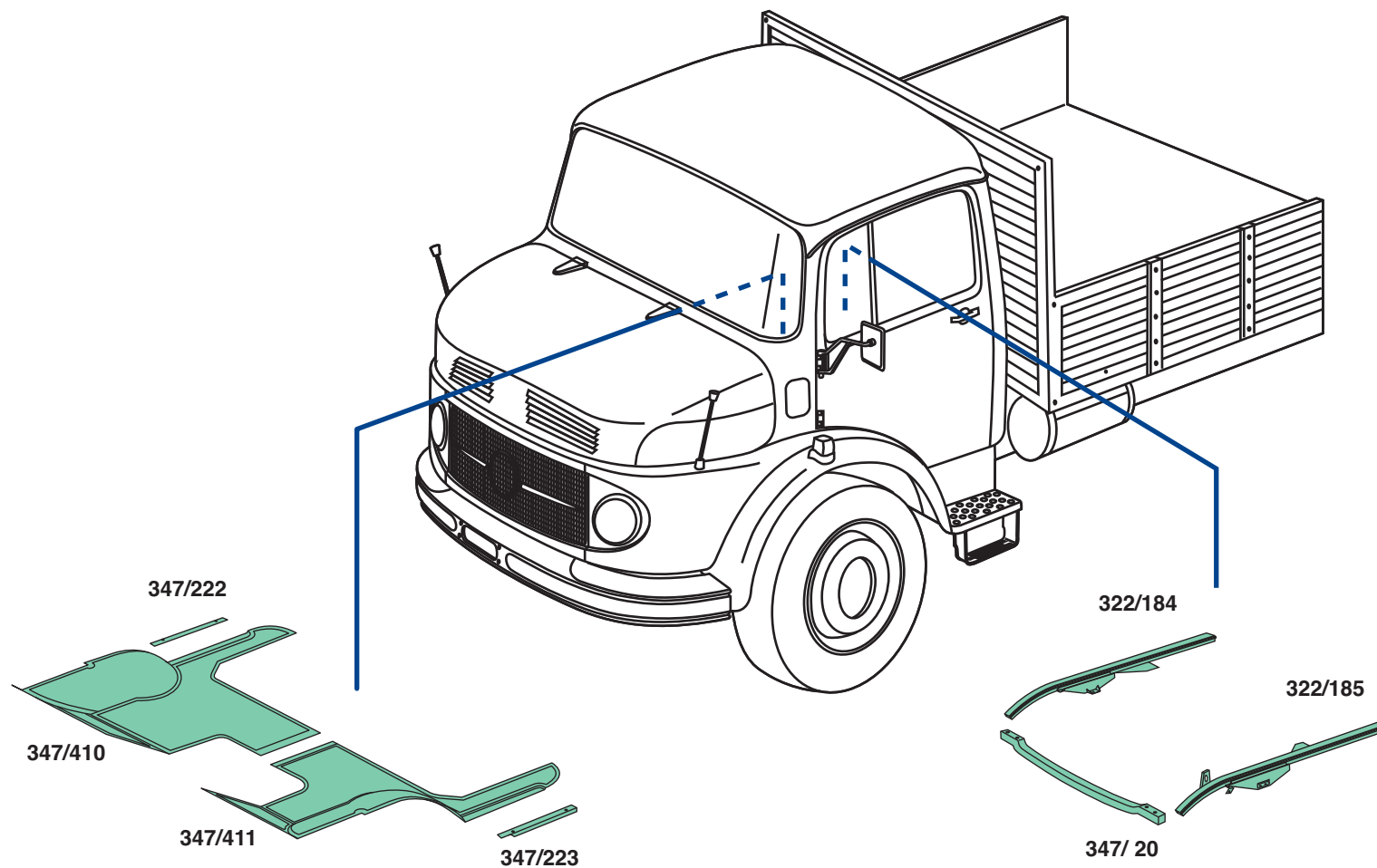

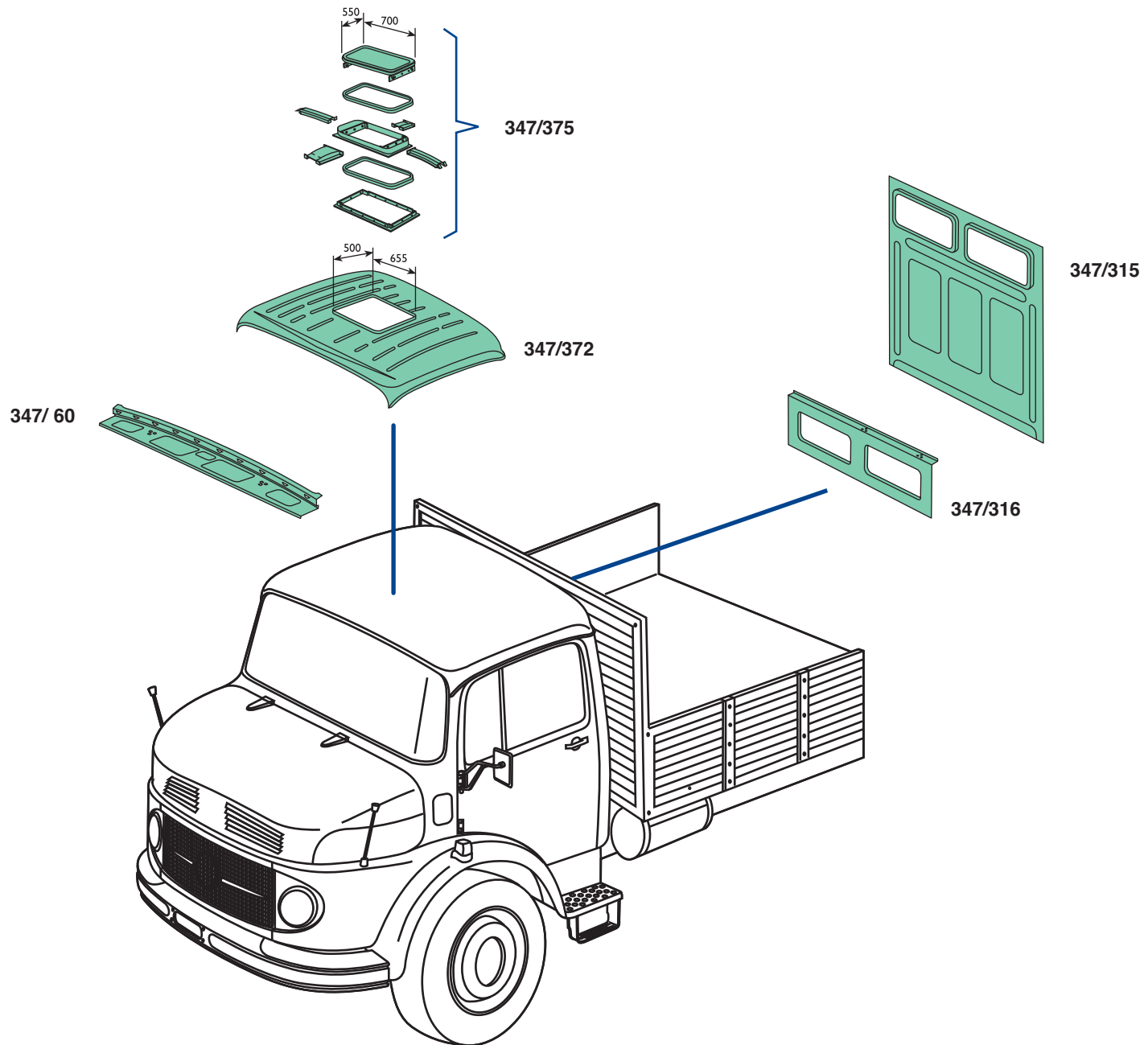

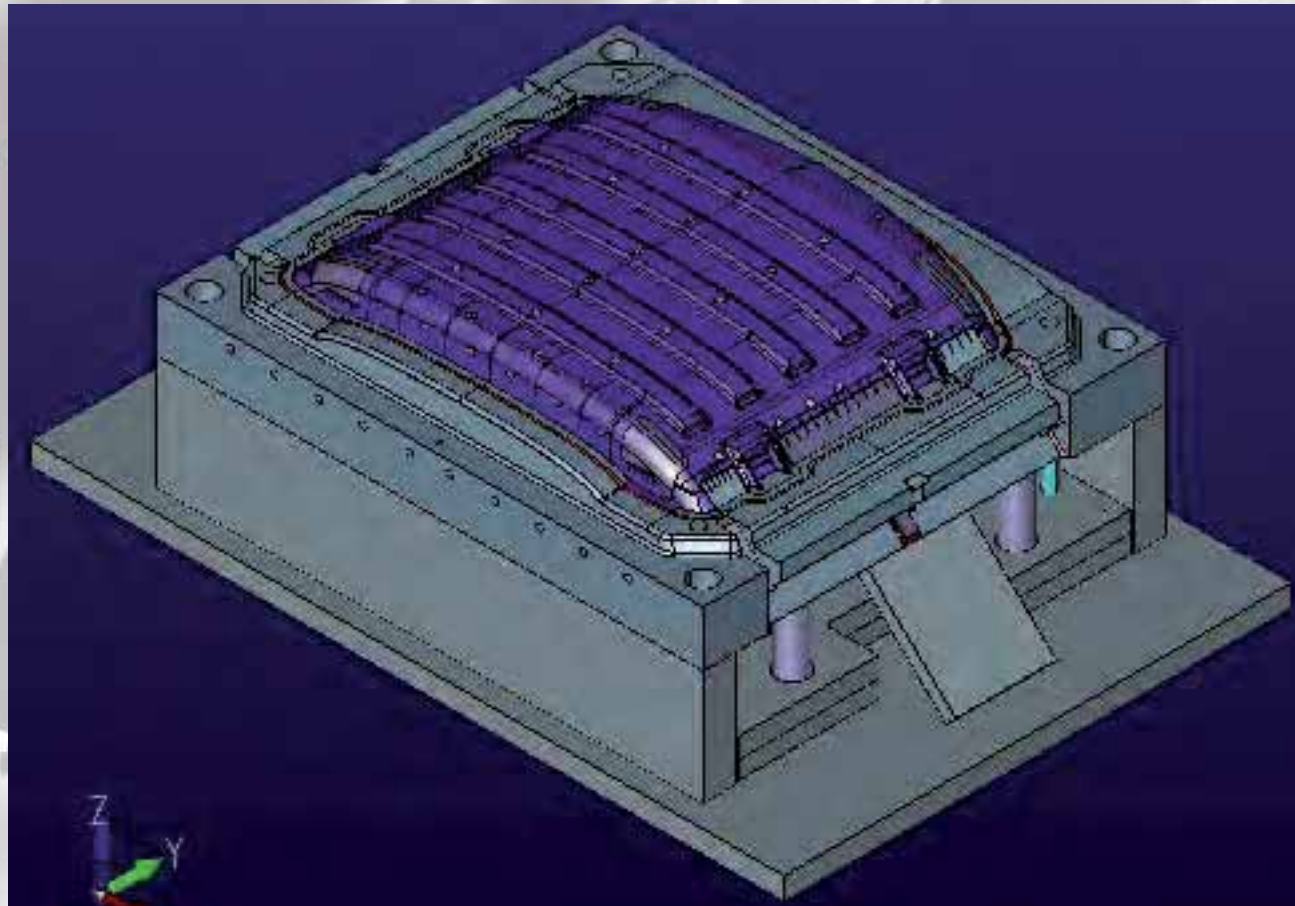

- ▲ IT Progetto in 3D dello stampo ad iniezione per la produzione della calotta per il veicolo Scania V8
- UK 3-D Project for the mould to be used for the production of top guard for the vehicle Scania V8((last model)
- DE 3D-Projekt der Stahlform für die Produktion der Kalotte, Fahrzeug Scania V8 letzte Typ (Modell)



- ▲ IT Stampo femmina in acciaio temprato per la realizzazione della calotta per il veicolo Scania V8
- UK Mould finishing process for the production of the top guard of the vehicle Scania V8 (last model)
- DE Geöffnete Stahlform für die Produktion der Kalotte des Fahrzeugs Scania V8 letzte Typ (Modell)

MERCEDES

MERCEDES-BENZ MB322
71-911-1113-1413-1513

229



230

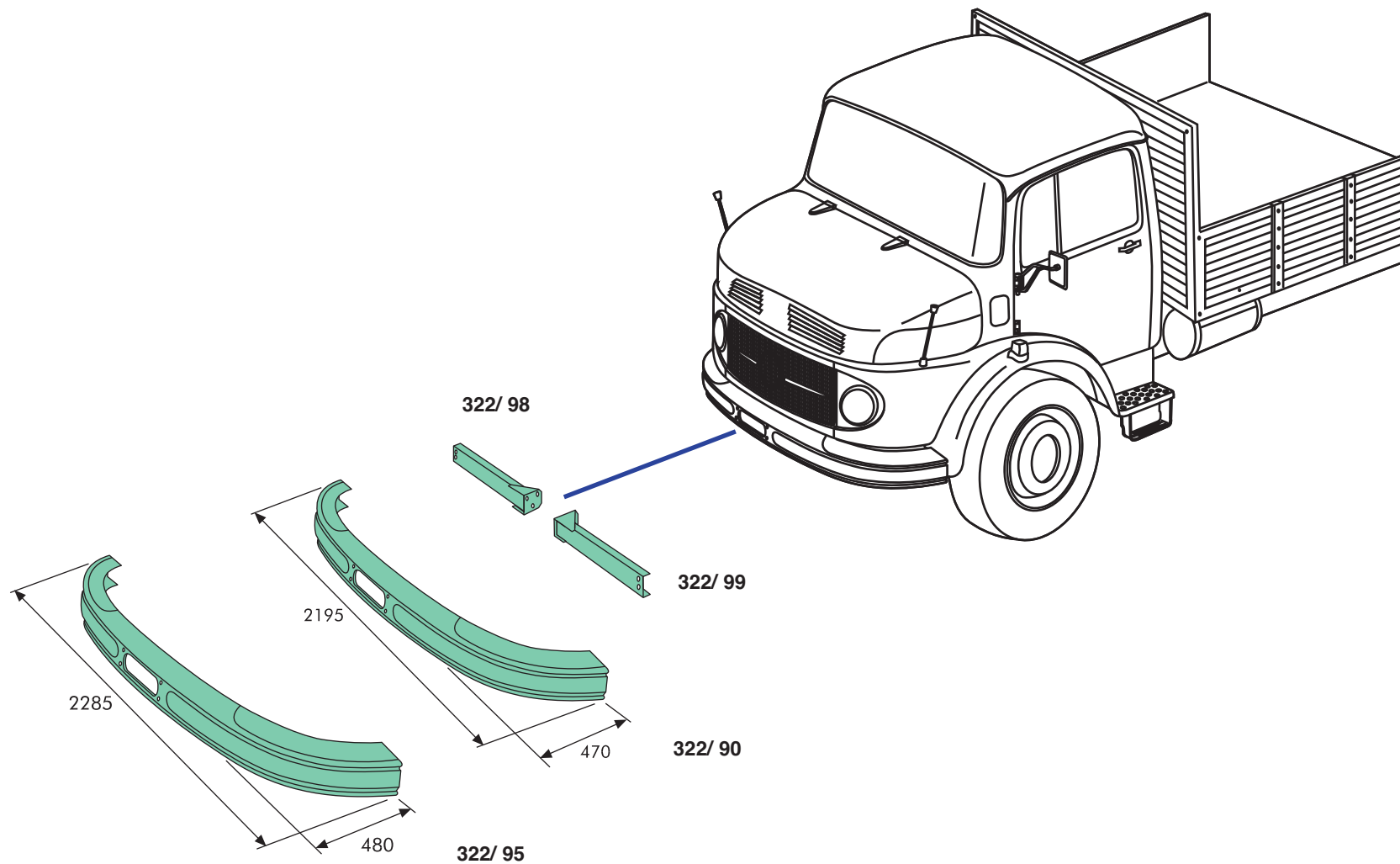

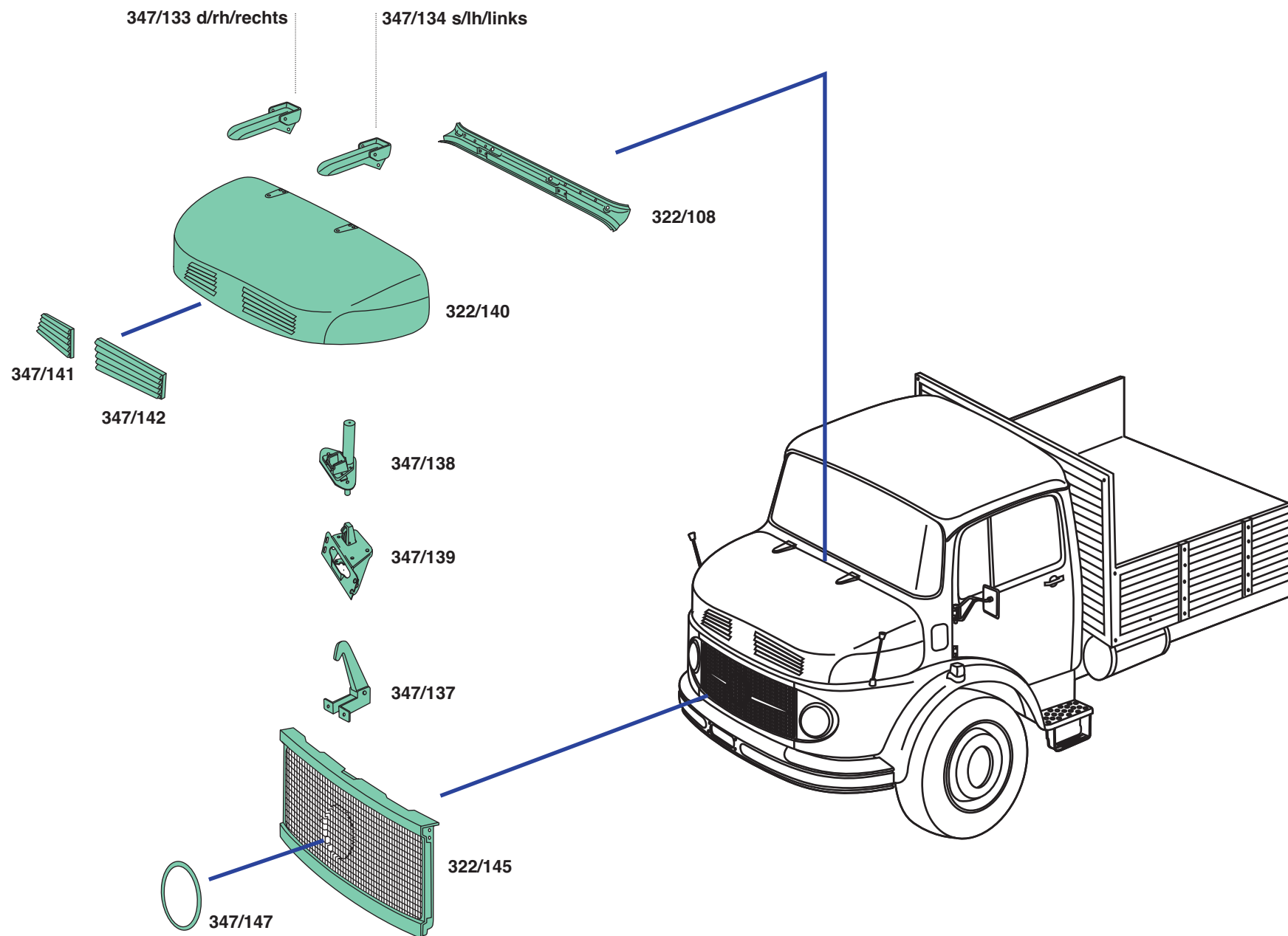

232

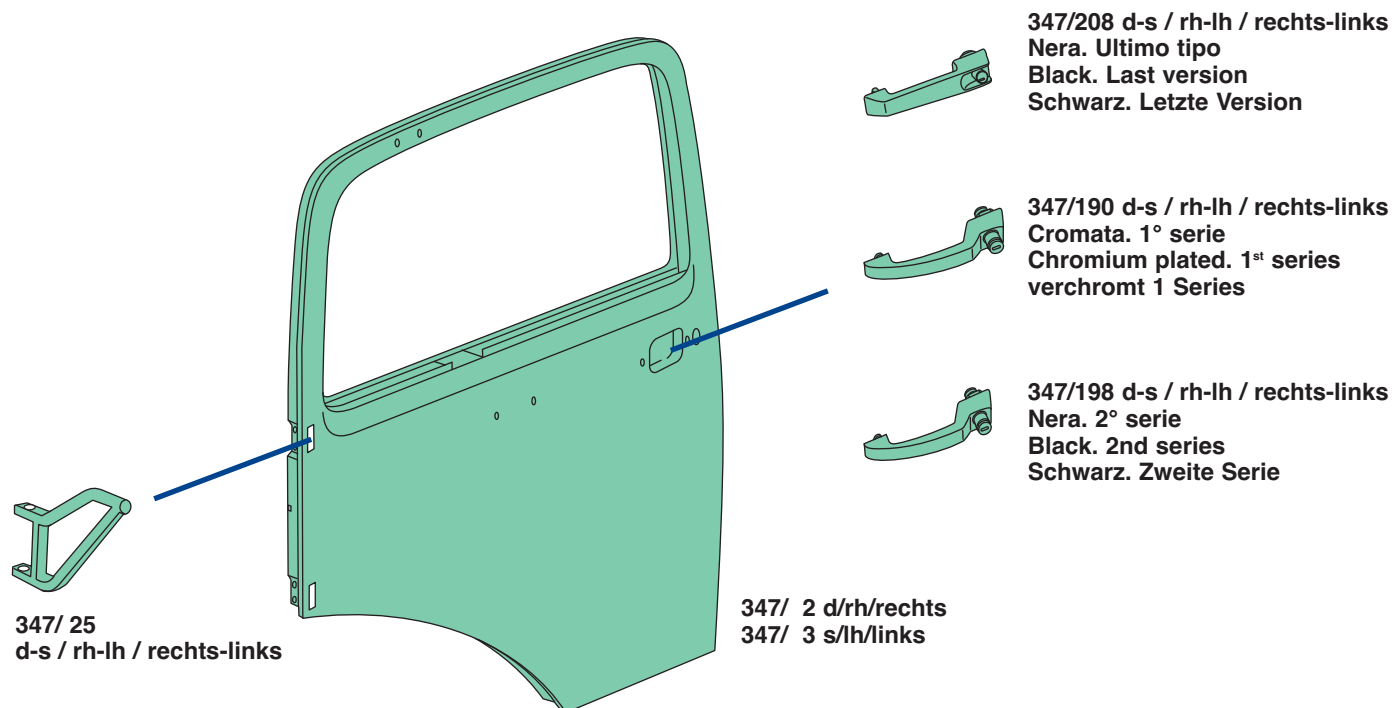

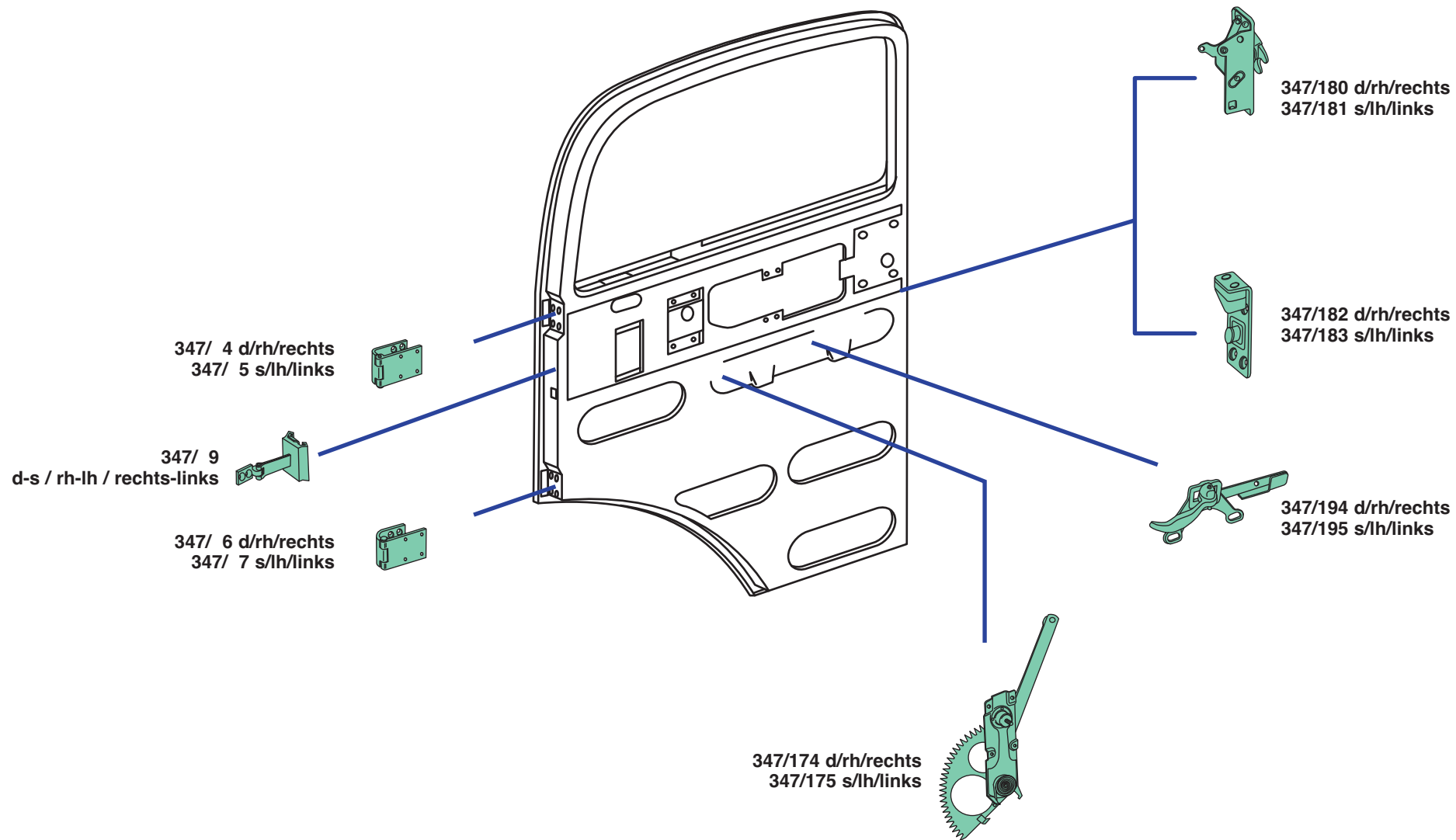

234

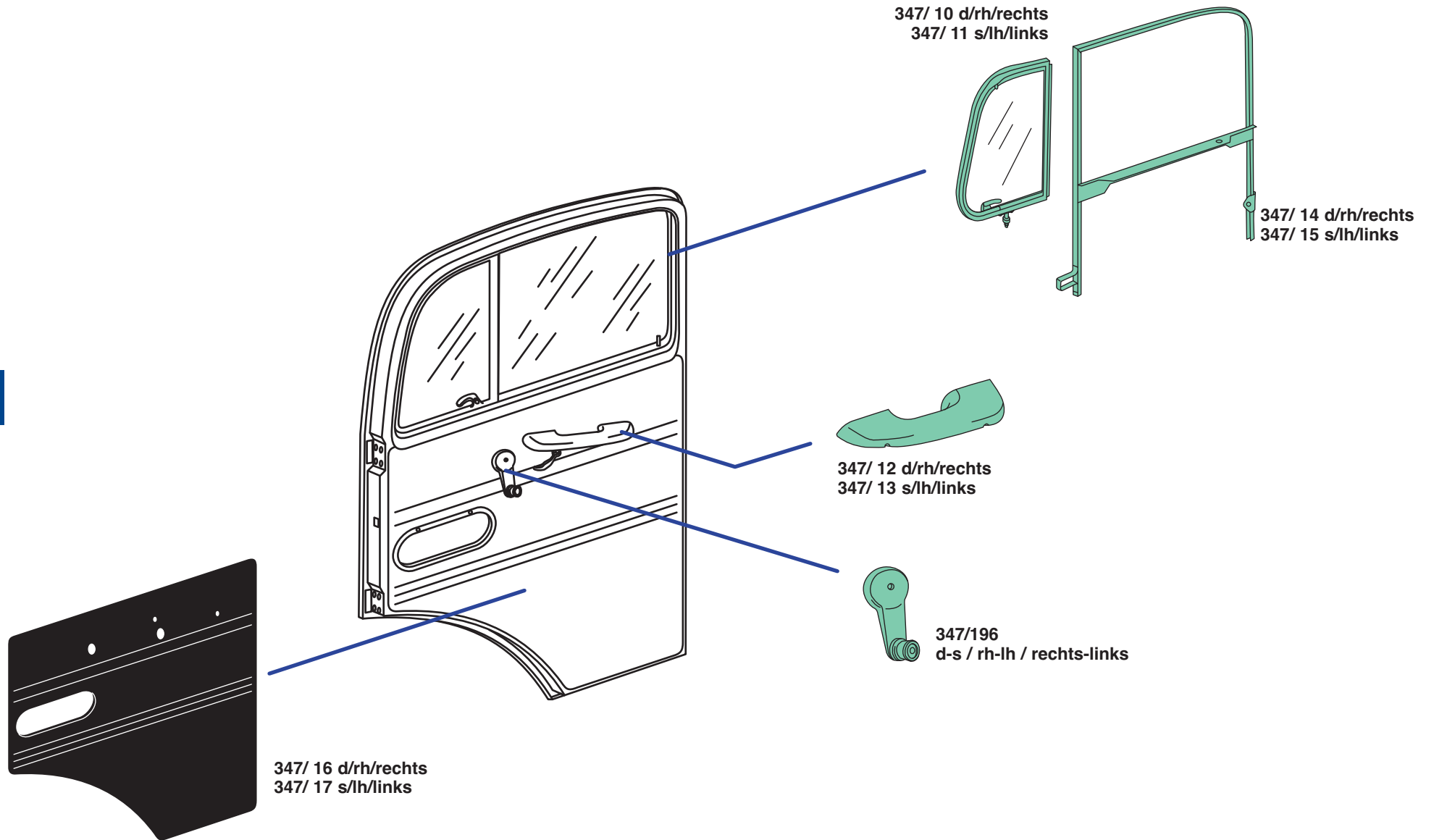

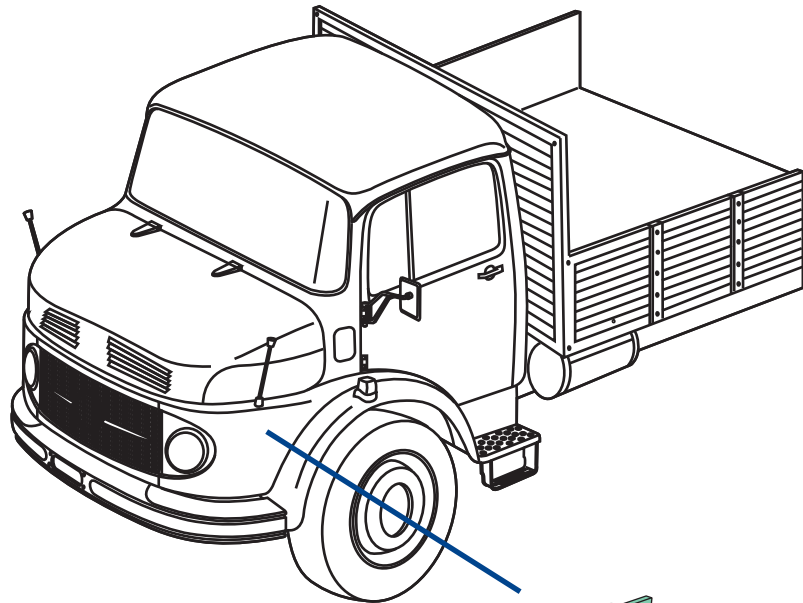

322/ 64 d/rh/rechts
322/ 65 s/lh/links

347/100

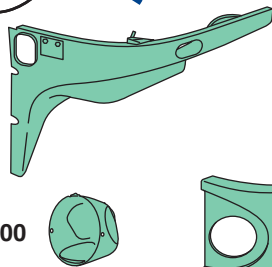

347/170

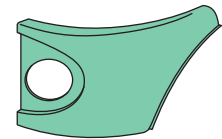

322/160 d/rh/rechts
322/161 s/lh/links



322/162
d/rh/rechts
322/163
s/lh/links



322/164 d/rh/rechts
322/165 s/lh/links

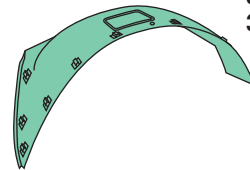

322/ 66 d/rh/rechts
322/ 67 s/lh/links

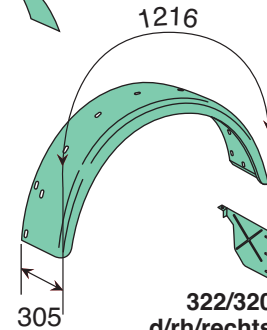

322/200 d/rh/rechts
322/201 s/lh/links

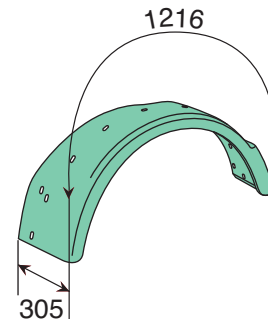

322/320
d/rh/rechts
322/321
s/lh/links

322/204 d/rh/rechts
322/205 s/lh/links

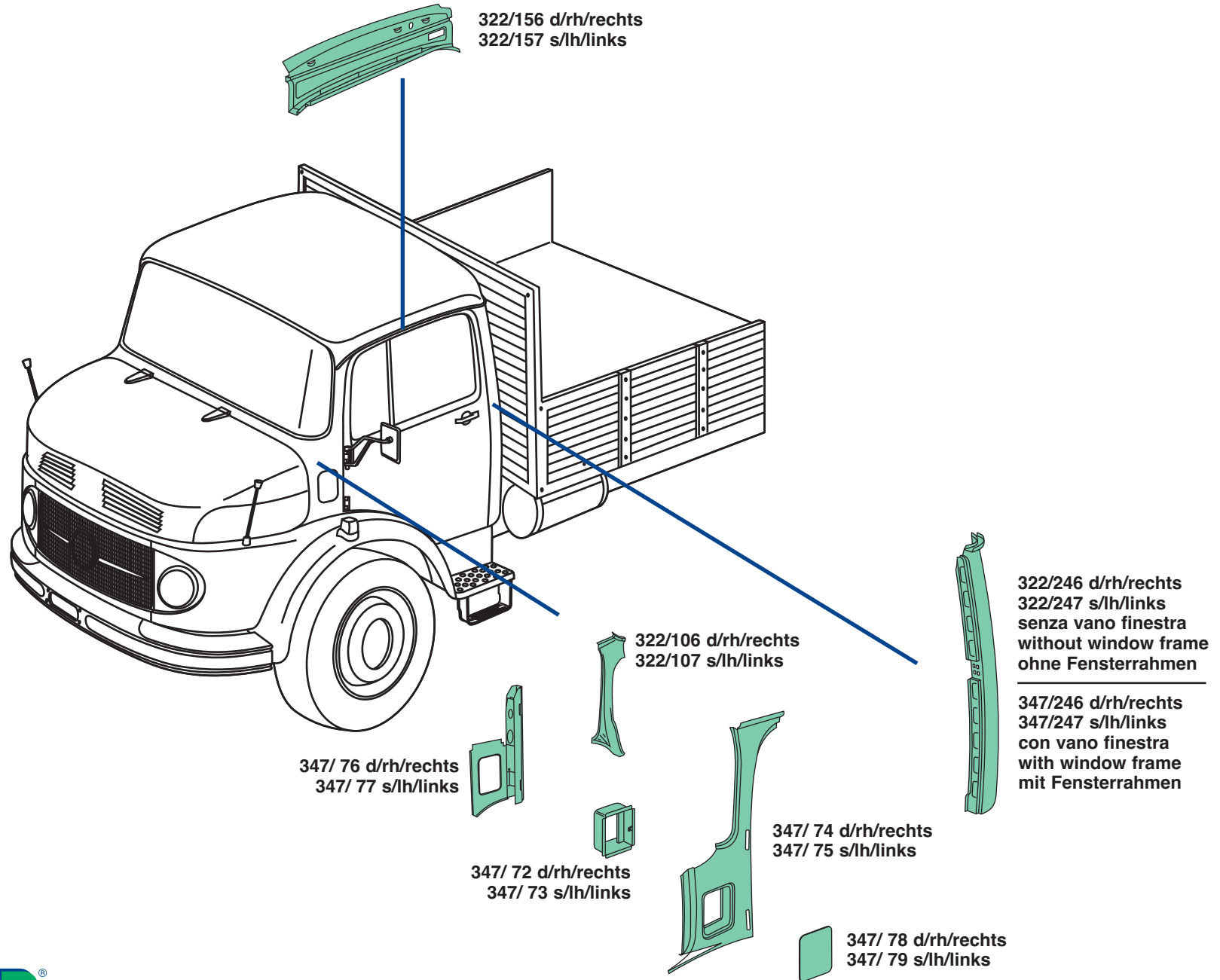

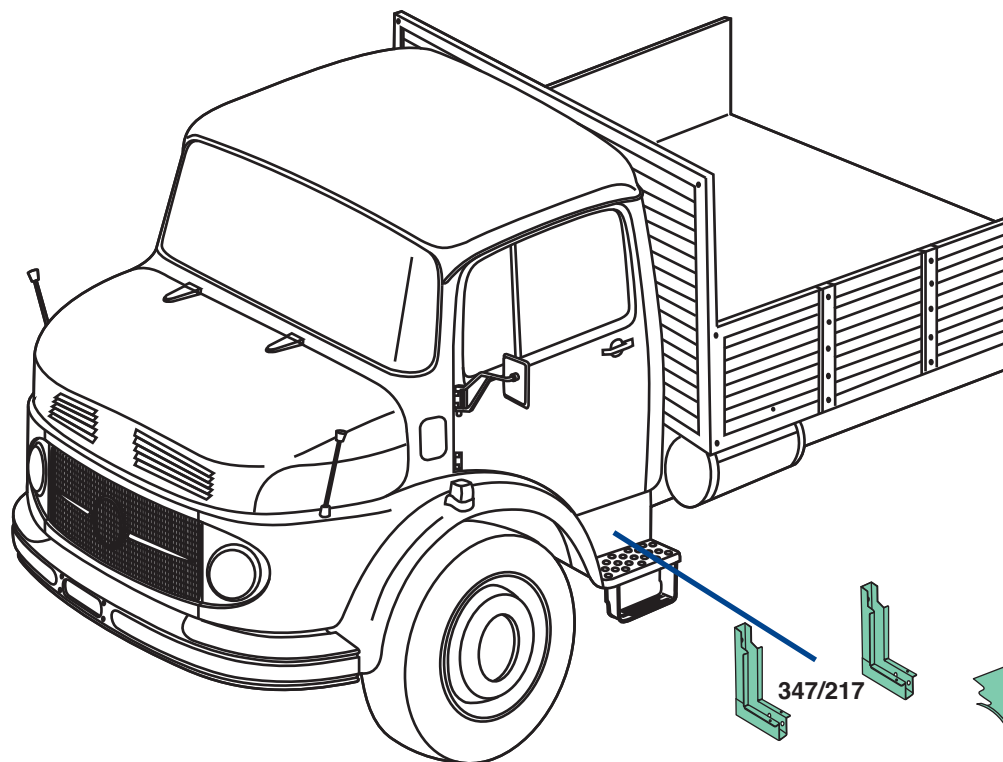

237

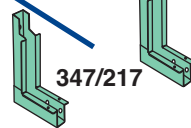

347/217



347/230 d/rh/rechts
347/231 s/lh/links

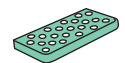

347/212 d/rh/rechts
347/213 s/lh/links



347/215
d-s / rh-lh / rechts-links

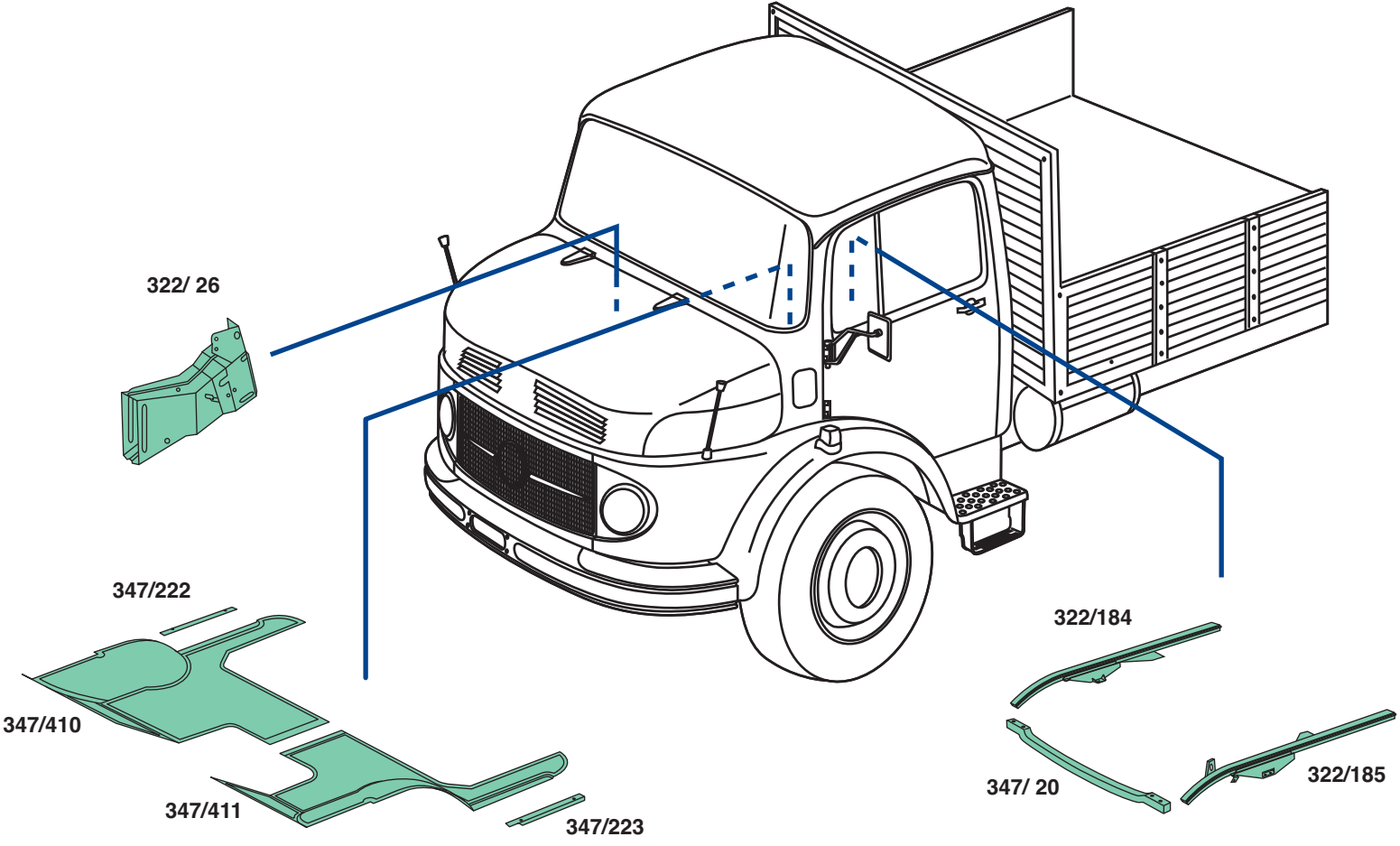

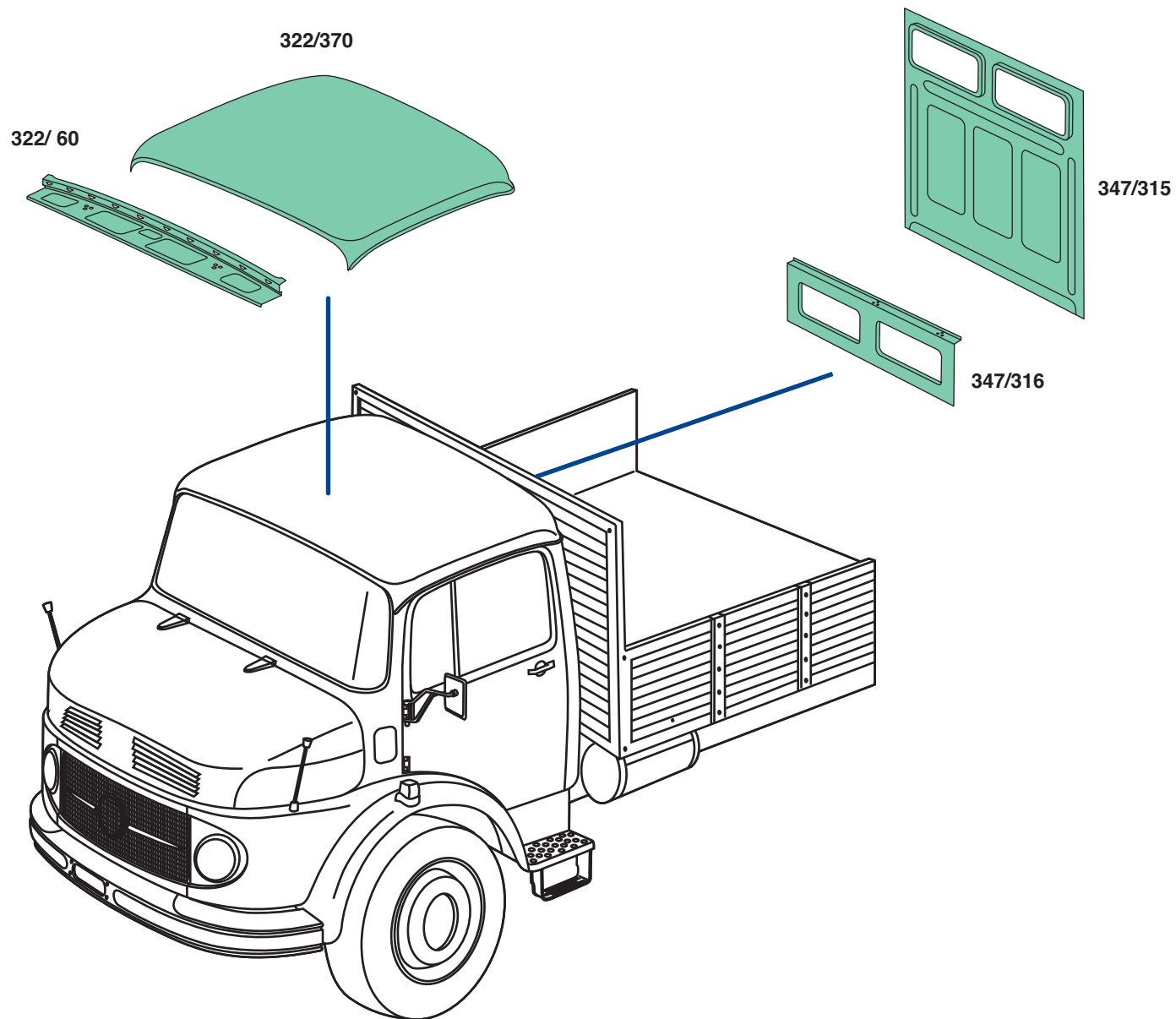

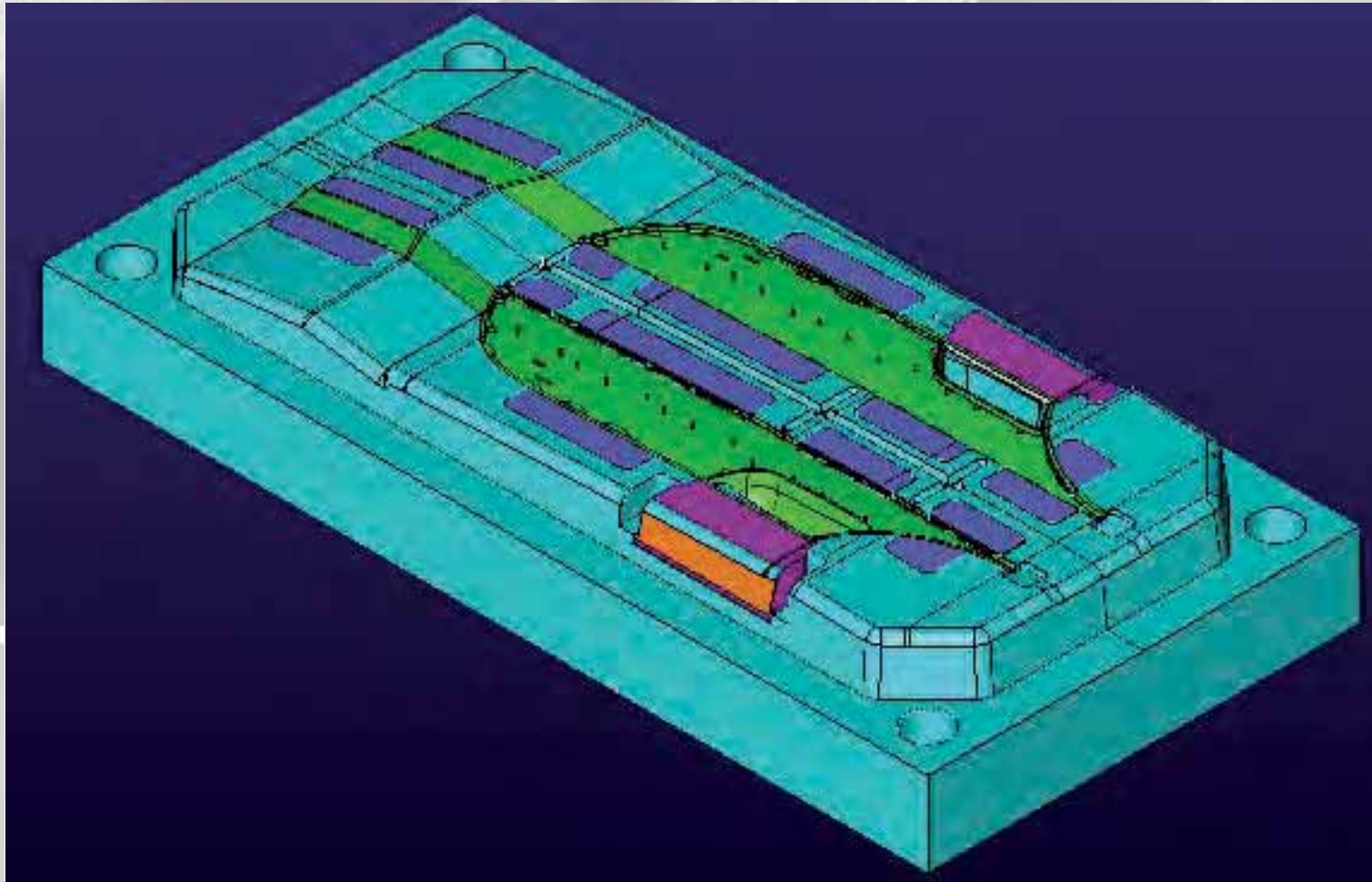

- ▲ IT Progetto in 3D dello stampo ad iniezione per la produzione di griglie sul frontale
- UK 3-D Project for the mould to be used for the production of grille
- DE 3D-Projekt der Stahlform für die Herstellung von Grill



- ▲ IT Stampo ad iniezione per la realizzazione delle griglie sul frontale
- UK Mould for the production of grille
- DE Stahlform für die Herstellung von Grill

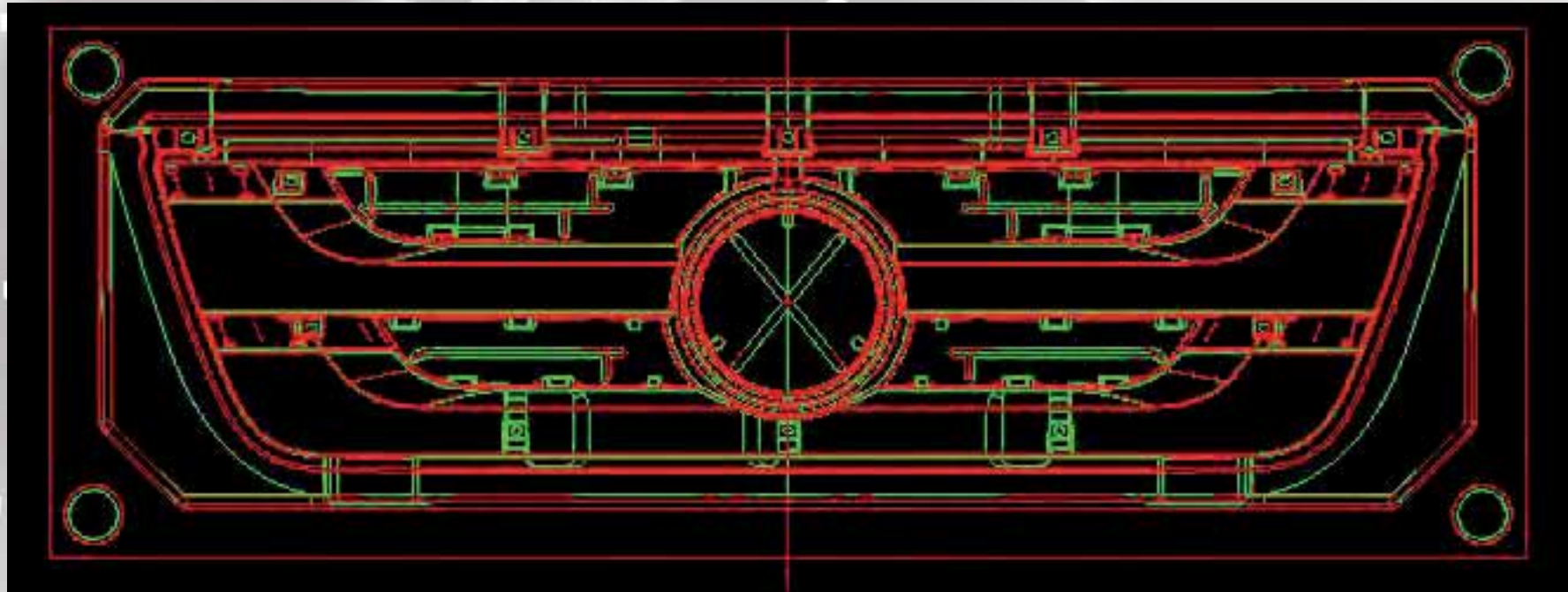

- ▲ IT Progetto in 3D dello stampo ad iniezione per la produzione di una griglia frontale
- UK 3-D Project for the mould to be used for the production of front grille
- DE 3D-Projekt der Stahlform für die Herstellung von Frontgrill

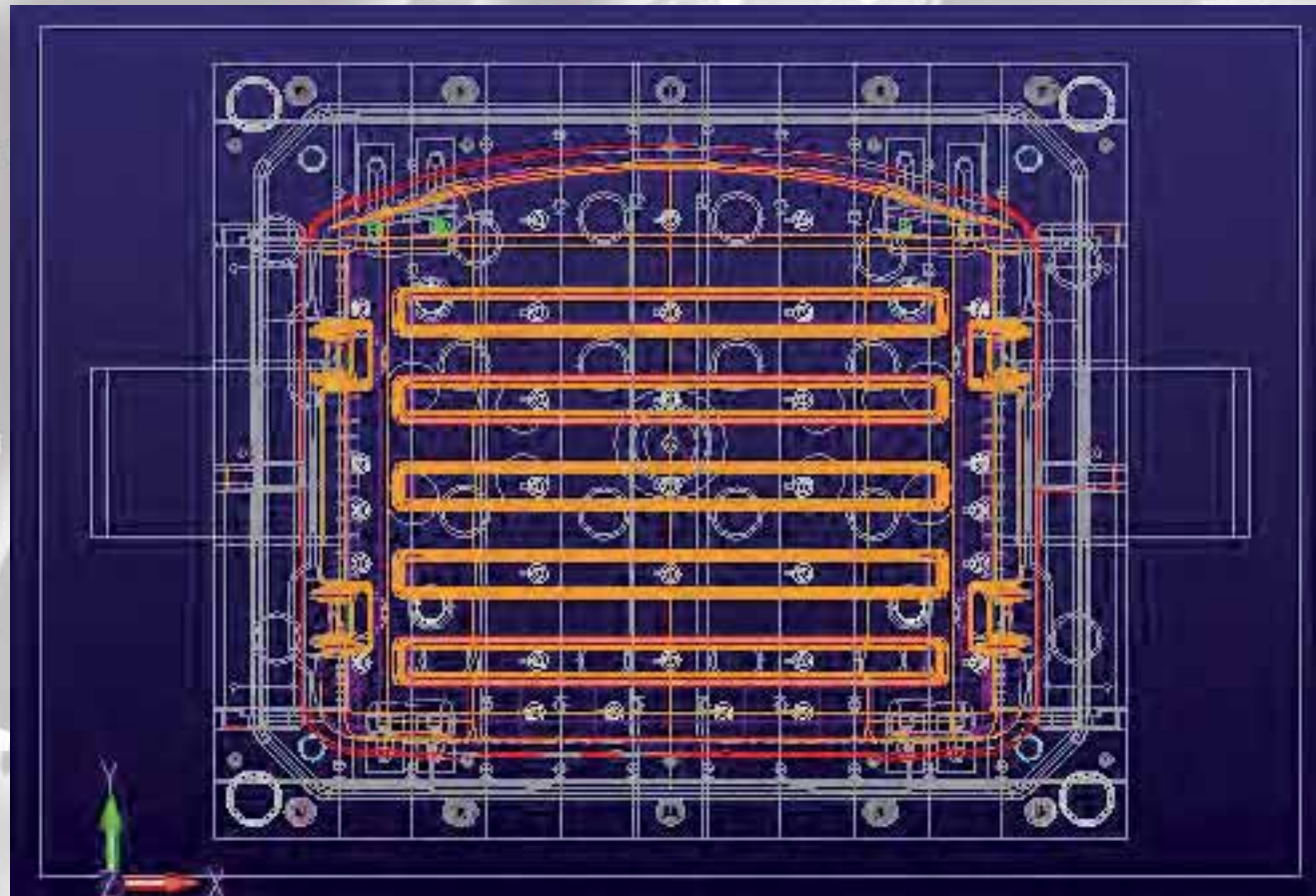

- ▲ IT Progetto in 3D dello stampo ad iniezione per la produzione della calotta per il veicolo Scania V8
- UK 3-D Project for the mould to be used for the production of top guard for the vehicle Scania V8((last model)
- DE 3D-Projekt der Stahlform für die Produktion der Kalotte, Fahrzeug Scania V8 letzte Typ (Modell)

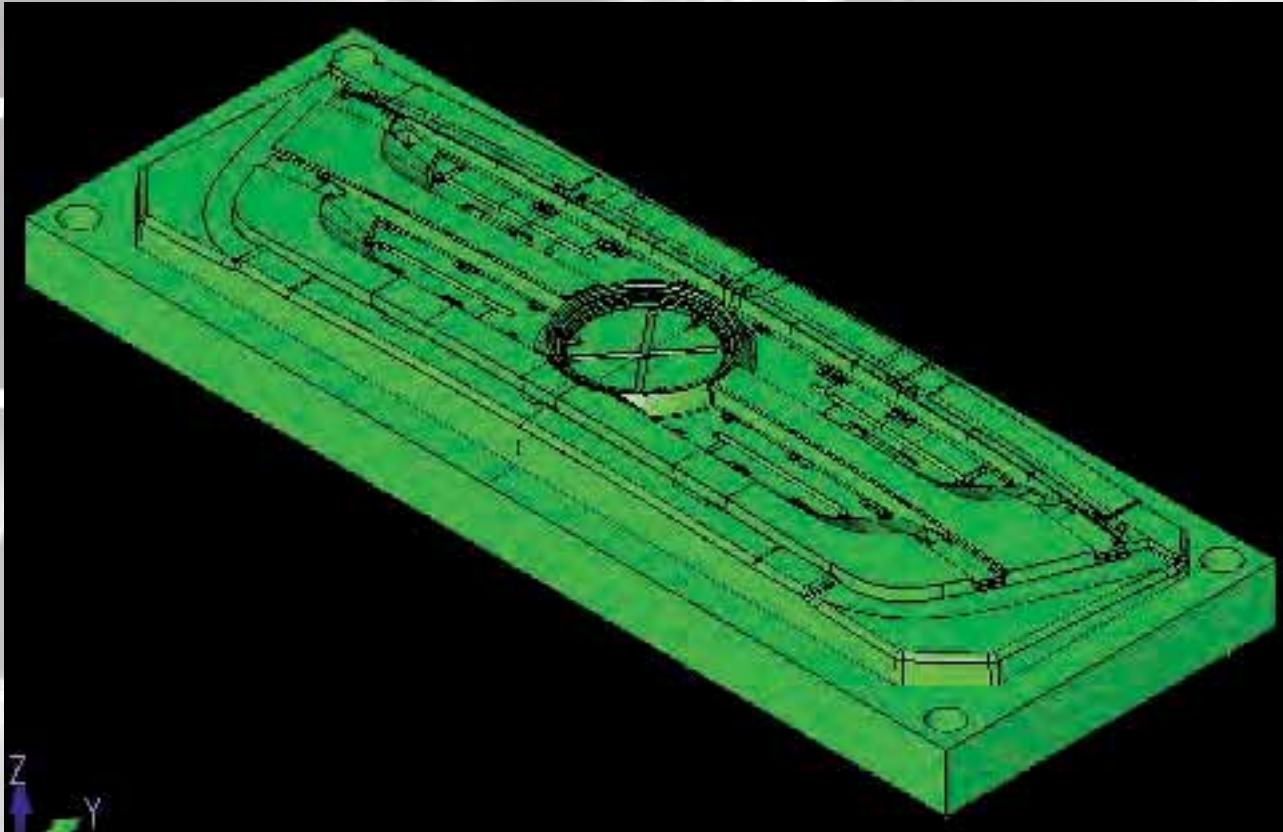

- ▲ IT Progetto in 3D dello stampo ad iniezione per la produzione di una griglia frontale
- UK 3-D Project for the mould to be used for the production of front grille
- DE 3D-Projekt der Stahlform für die Herstellung von Frontgrill

COVIND SPA

SERVIZIO VENDITE ITALIA DOMESTIC SALES OPT.

 +39 011 8965719

 +39 011 8965714

 +39 011 8965702

 +39 011 8965723

 +39 011 8965756

E.MAIL vendite@covind.it

SERVIZIO VENDITE ESTERO INTERNATIONAL SALES OPT.

 +39 011 8965716

 +39 011 8965736

 +39 011 8965713

 +39 011 8965739

 +39 011 8965738

 +39 011 8965744

 +39 011 8005149

E.MAIL export@covind.it



COVIND S.P.A.

Strada della Cebrosa, 68/70/72
10036 Settimo Torinese (TO) - ITALY

☎. +39 011 8965711

☎. +39 011 8977830

✉. marketing@covind.it

www.covind.it



MOD2MER07

