

MAN

marzo 2011
march 2011
März 2011

catalogo--catalogue--catalogo
re--catalogo--catalogo
--catalogo--catalogo





COVIND S.p.A.
Strada della Cebrosa, 68
10036 Settimo T.se (TO)

STAMPAUTO S.r.l.

Via Alessandria, 59/61
10090 Cascine Vica (TO) - Italy



KARMAN STAMPOTECH S.r.l.

Via Torino, 10/12
10060 Airasca (TO) - Italy



- Autostrada Motorway
- Tangenziale Circular Road
- Provinciale Country Road
- Comunale Municipal Road



**Nuovo Stabilimento
New Warehouse**
Via Raspini, 3-3bis
10036 Settimo T.se (TO)

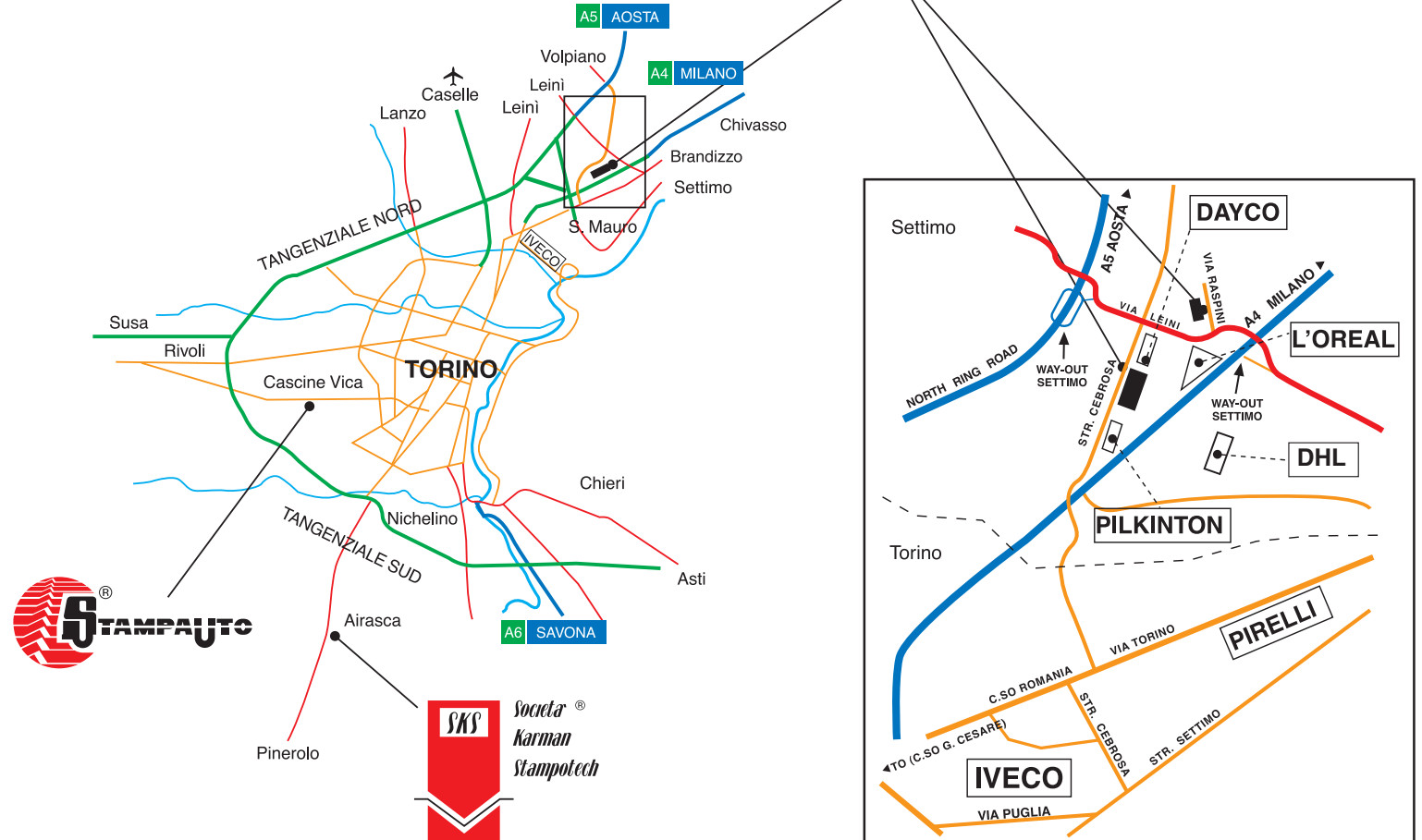



Tutti i particolari qui elencati, pur essendo perfettamente intercambiabili con gli originali, **non sono originali**. Gli stessi vengono impiegati ed utilizzati solo per i veicoli in circolazione e solo dopo autorizzazione da parte del proprietario del veicolo in riparazione. I numeri di riferimento originali sono riportati a puro titolo informativo. Nelle trattative e nelle ordinazioni si prega di voler sempre citare i nostri numeri di riferimento. Il presente catalogo annulla e sostituisce tutti i precedenti.



Todos los elementos detallados a continuación, aunque totalmente intercambiables con los originales, **no son originales**. Estos mismos se emplean y utilizan unicamente para vehículos en circulación y previa autorización del propietario del vehículo en reparación. Los numeros de referencia originales se citan a título informativo. En las negociaciones y en los pedidos se ruega citar siempre nuestros numeros de referencia. El presente catálogo anula y substituye todos los anteriores.



Κάθε ανταλλακτικό που απαριθμείται εδώ, ακόμα κι αν όντας τέλεια ανταλλάξιμο με το γνήσιο, **δεν είναι γνήσιο**. Αυτά τα μέρη χρησιμοποιούνται μόνο στα οχήματα που είναι σε κυκλοφορία και αποκλειστικά μετά από την έγκριση του ιδιοκτήτη του οχήματος για επισκευή. Οι γνήσιοι κωδικοί που αναφέρονται υπάρχουν για πληροφοριακούς λόγους μόνο. Παρακαλούμε όπως χρησιμοποιείτε για οποιαδήποτε συναλλαγή/ παραγγελία σας τους δικούς μας αναφερόμενους κωδικούς. Ο παρών κατάλογος ακυρώνει και αντικαθιστά προηγούμενους.



Spare parts listed here, even though perfectly interchangeable with the original ones, **are not original**. These parts are used only on vehicles in circulation and exclusively under authorization of the owner of the vehicle in repair. The original reference codes are indicated for information only. You are kindly requested to indicate our reference codes in negotiations and order sheets. The present catalogue list cancels and replaces previous ones.



Veškeré zde uvedené součástky **nejsou originální díly**, i když jsou za ně stoprocentně zaměnitelné. Tyto součástky je možné použít pouze pro vozidla v provozu a pouze se souhlasem majitele vozidla, které má být opraveno. Referenční čísla originálních dílů jsou uvedena pouze informativně. Při jednáních a na objednávkách je nutné vždy uvést naše referenční čísla. Tento katalog anuluje a nahrazuje veškeré předchozí katalogy.



Hoewel elk reserveonderdeel dat hier vermeld wordt perfect kan worden gebruikt in de plaats van de originele stukken, **gaat het hier dus niet om originele onderdelen**. Deze onderdelen worden enkel gebruikt voor voertuigen in circulatie en enkel met de toestemming van de eigenaar van het voertuig dat in reparatie is. De originele referentiecodes worden enkel ter informatie weergegeven. U wordt vriendelijk verzocht om onze referentiecodes te gebruiken in gesprekken en op de bestelformulieren. De huidige catalogoog annuleert en vervangt de vorige versies.



Reservedelene som er oppført her, er ikke **originale reservedeler**, selv om de fullt ut kan benyttes ved utskifting av de opprinnelige delene. De skal kun benyttes på kjøretøy som er i bruk og med eierens samtykke. De opprinnelige referansekodene angis kun til etterretning. Vennligst angi våre referansekoder under forhandling og ved bestilling. Denne katalogen annullerer og erstatter alle tidligere kataloger.



Toate produsele enumerate in continuare, chiar daca sunt perfect interschimbabile cu cele originale, **nu sunt originale**. Ele sunt utilizate, numai pentru autovehiculele in circulatie si exclusiv cu acordul proprietarului autovehiculului de reparat. Codurile originale sunt indicate numai in scop informativ. Cu ocazia tratativelor verbale, cat si a emiterii ordinelor scrise, clientii sunt rugati sa utilizeze codurile noastre(COVIND) ca referinta. Prezentul catalog anuleaza si le inlocuieste pe cele precedente.



Wszystkie detale tu podane ,choć będąc doskonałe wymienne z oryginałami, **nie są oryginalne**. Te same zostają zastosowane i użyte tylko dla pojazdów w obiegu i tylko po autoryzacji ze strony właściciela pojazdu będącego w naprawie. Oryginalne numery referencyjne są umieszczone w celu czysto informacyjnym. W czasie rozmów handlowych i zamówień, prosi się zechcieć zawsze cytować nasze numery referencyjne. Niniejszy katalog anuluje i zastępuje wszystkie poprzednie.



Todas as peças aqui listadas, ainda que sejam perfeitamente intercambiáveis com as originais, **não são originais**. Estas peças só são empregues e utilizadas nos veículos em circulação e só após autorização prévia por parte do proprietário do veículo a reparar. Os números de referência originais têm um carácter puramente informativo. Nos contactos e encomendas, indique sempre os números de referência, por favor.



Selv om de sagtens kan bruges i stedet for de originale er de reservedele der indgår i **denne liste ikke originale**. Disse reservedele bruges kun til aktive køretøjer og udelukkende med ejerens tilladelse, mens reparationen udføres. De originale referencekoder fremstår kun som en oplysning. De bedes angive vores referencekoder i.f.m. forhandlinger og bestillingssedler. Det nye katalog annullerer og erstatter alle tidligere udgaver.



Reservdelarna i denna lista är inte originaldelar trots att de **är fullkomligt utbytbara med de ursprungliga**. Dessa delar används endast på fordon i cirkulation och enbart efter godkännande av ägaren till det fordon som lämnats på reparation. De originala referenskoderna anges endast för information. Var god ange våra referenskoder i negocieringar och beställningssblanketter. Den nuvarande kataloglistan annullerar och ersätter de föregående.



Alle hier aufgeführten Bestandteile sind exakt austauschbar mit den Originalteilen, **aber es sind keine Originale**. Diese Teile werden nur angewendet und eingesetzt für die Fahrzeuge die im Umlauf sind und nur nach Einverständnis mit dem Eigentümer, dessen Fahrzeug in der Reparatur ist. Die Original-Referenznummern wurden rein informativ nochmals wiedergegeben. Bei Anfragen und bei Bestellungen bitten wir Sie immer die Referenznummern anzugeben. Der beigelegte Katalog ersetzt und annulliert die vorhergehenden Kataloge.



Всички особености изредени по-долу, независимо от това, че са взаимозаменяеми с оригиналите, **не са оригинали**. Те биват използвани само за превозните средства в движение и само след изпълномощаване от страна на собственика на превозното средство в ремонт.



Toutes les pièces détaillées ci-dessus, tout en étant parfaitement interchangeable avec les pièces d'origine, **ne sont pas originales**. Les mêmes pièces sont utilisées exclusivement sur les véhicules en circulation et seulement sous autorisation du propriétaire du véhicule en réparation. Les codes de référence originales sont indiqués à titre purement documentaire. Dans les négociations et les commandes veuillez bien citer nos codes de référence. Le présent catalogue annule et remplace tous les précédents.



Все перечисленные запчасти не являются оригинальными, **хотя могут отлично их заменить**. Эти запчасти используются при ремонте автомобилей только с согласия владельца.

Ссылки на порядковый номер оригинальных запчастей указаны исключительно в ориентировочных целях.

При покупках и заказах рекомендуем указывать НАШИ номера запчастей.

Настоящий каталог аннулирует и заменяет все предыдущие.

Оригинальные ориентировочные номера са изнесени само за ваша информация. При преговори и при поръчки молим винаги да цитирате нашите ориентировочни номера.

Настоящият каталог анулира и замества всички съществуващи до момента.



Tässä luetteloidut varaosat eivät ole alkuperäisosa, vaikka **ne ovatkin laadultaan alkuperäisosa vastaavia**. Osat on tarkoitettu käytettäväksi liikenteessä olevissa autoissa ja niitä käytetään vain korjattavan ajoneuvon omistajan luvalla. Alkuperäiset tuotekoodit mainitaan vain tiedon vuoksi. Pyydämme teitä käyttämään neuvotteluissa ja tilauslomakkeissa meidän tuotekoodejamme. Uusi tuoteluettelo peruuttaa ja korvaa aikaisemmat luettelot.



Selles nimekirjas olevad varuosad ei ole originaalid vaatamata sellele, **et on originaalidega võrdväärselt kasutatavad**. Neid osasid kasutada ainult töös olevatel sõidukitel ja üksnes remonditava sõiduki omaniku loal. Originaali viitenumbrid on ära toodud ainult infoks. Palume müügi- ja tellimislehtedel ära märkida meie viitenumbrid. Käesoleva kataloogi nimekiri tühistab ja asendab varasemad.



Devamında detaylandırılan tüm elementler, orijinaleri ile tamamen değiştirilebilir olmasına rağmen, **orijinal değildirler**. Bunlar, yalnızca dolaşımda bulunan araçlarda ve tamirde bulunan aracın sahibinden ön onay alınması kaydıyla uygulanabilir ve kullanılabilir.
Orijinalerin referans numaraları bilgi başlığında yer almaktadır.
Görüşmelerde ve siparişlerde referans numaralarımızın her zaman belirtilmesi rica olunur.
Bu katalog tüm önceki versiyonları geçersiz kılar ve bunların yerine geçer.



Kaut arī uzskaitītās rezerves daļas var pilnīgi aizstāt oriģinālās, **tās nav oriģinālas**. Šīs rezerves daļas tiek izmantotas vienīgi apgrozībā esošiem transporta līdzekļiem un tikai ar remontējamā transporta līdzekļa īpašnieka atļauju.
Oriģinālais atsauces numurs tiek uzrādīts vienīgi informācijai.
Lūdzam norādīt jūsu atsauces numurus sarunu laikā un uz pasūtījuma lapas. Šis kataloga saraksts anulē un aizstāj visus iepriekšējos.



Az itt felsorolt tartalék alkatrészek, még akkor is, ha megfelelően felcserélhetők az eredetiekkel, nem az eredetiek. Ezeket az alkatrészeket csak forgalomban lévő járművek javításánál használják és kizárólag a jármű tulajdonosának engedélyével.
Az eredeti referencia kódokat csak információs célból jelzik. Kérjük legyen szíves jelezze a referencia kódjainkat a tárgyalásokon és a megrendelési dokumentumban.
A jelenlegi katalógus lista vissza van vonva és újra az előző lista van érvényben.



Ovdje popisani prièuvni dijelovi, èak i kada savršeno zamjenjuju izvorne, **nisu izvorni**. Ti dijelovi mogu se uporabiti jedino na vozilima u cirkulaciji i na temelju izrièelitoga odobrenja vlasnika vozila na popravku.
Brojevi dijela izvornih dijelova navedeni su samo kao primjer. Najljepše vas molimo da u vašim zahtjevima i narudžbama navedete brojeve dijela.
Sadašnji katalog ukida valjanost svih prethodnih kataloga.



كافة التفاصيل المذكوره هنا وبالرغم من قابليتها للتبديل مع التفاصيل الاصليه بشكل متطابق تماما، إلا انها ليست الاصليه، نفس التفاصيل يتم الاستعانه بها واستخدامها فقط للعربات السائره فقط بعد الحصول على التصريح بالموافقه من مالك العربيه التي يتم اصلاحها.
الأرقام الارشاديه الاصليه يتم وضعها بغرض الاستعلام. نرجو أن يتم دائما ذكر أرقامنا الخاصة الارشاديه في التعاقدات وطلبات الشراء.
هذا الكاتالوج يلغي كافة الكاتالوجات السابقه ويحل محلها.



Перелічені тут запасні частини не є оригінальними, але цілком взаємозамінні з оригінальними. Ці запасні частини застосовуються тільки на транспортних засобах, що знаходяться в експлуатації і винятково з дозволу власника, що здав транспортний засіб у ремонт.

Коди оригінальних запасних частин наводяться тільки для довідки. Прохання вказувати довідкові коди запасних частин при веденні переговорів і на бланках замовлення.

Даний каталог скасовує дію раніше виданих каталогів і замінює ці каталоги.



Ěprav jih je možno perfektno izmenjati z originalnimi deli, tukaj navedeni nadomestni deli niso originalni. Te dele se uporabljajo samo v vozilih v prometu in izključeno samo pod pogojem, da lastnika vozila v popravilu izda zato dovoljenje. Navedene originalne referenčne kode so le informativne. Prosimo vas, da navedite naše referenčne kode pri pogajanju in na naročilih. S sedanjim seznamom prenehajo veljati prejšnji sezname in jih nadomesti.



Čia išvardytos atsarginės dalys nėra originalios, tačiau jomis galima pakeisti originaliąsias. Šios dalys naudojamos tik apyvartoje esančiuose automobiliuose ir tik gavus remontuojamo automobilio savininko sutikimą.

Originalių dalių kodai nurodomi tik informacijos sumetimais. Maloniai prašome nusiskundimuose ir užsakymų lapuose nurodyti dalių kodus.

Šiame kataloge pateikiamas sąrašas anuliuoja ir pakeičia ankstesniusius.



قطعات قید شده در اینجا با اینکه کاملاً قابل تعویض با قطعات اصلی می باشند. قطعات اصلی نیستند. این قطعات تنها برای خودروهایی که در جریان می باشند (خارج از محل تولید می باشند) مورد استفاده قرار می گیرند و منحصرأ تحت اختیار و نضر مالک خودروی در حال تعمیر می باشند.
با احترامات ما از شما شماره کد ارجاع اصلی تنها برای اطلاعات می باشند. تقاضا داریم که شماره کد ارجاع را در زمان مذاکره و در ورقه تقاضا مشخص کنید. لیست

Tabelle Comparative / Cross Reference / Vergleichsliste / Umschlüsselungsliste

Man / Covind	pagina/page/seite	3
--------------	-------------------	---

Covind / Man	pagina/page/seite	7
--------------	-------------------	---

Man

Man TGL	pagina/page/seite	11
---------	-------------------	----

Man F2000	pagina/page/seite	21
-----------	-------------------	----

Man F2000 Cava-Cantiere / Yard & Quarry / Baustellefahrzeug	pagina/page/seite	35
---	-------------------	----

Man TGA M-L-LX	pagina/page/seite	45
----------------	-------------------	----

Man TGA Cava-Cantiere / Yard & Quarry / Baustellefahrzeug	pagina/page/seite	53
---	-------------------	----

Man TGA XLX-XXL	pagina/page/seite	55
-----------------	-------------------	----

Man TGS	pagina/page/seite	63
---------	-------------------	----

Man TGS Cava-Cantiere / Yard & Quarry / Baustellefahrzeug	pagina/page/seite	73
---	-------------------	----

Man TGX	pagina/page/seite	75
---------	-------------------	----

Cod. Originale O.E.M. Ref.	Cod. Covind Covind ref.	pag. Cat. page Cat.	Cod. Originale O.E.M. Ref.	Cod. Covind Covind ref.	pag. Cat. page Cat.	Cod. Originale O.E.M. Ref.	Cod. Covind Covind ref.	pag. Cat. page Cat.
-	940/950	54	81416100158	M20/ 86	23	81416100405	XXL/ 90	56
-	940/960	54	81416100159	M20/ 87	23	81416102881	XXL/ 97	56
-	M20/ 4	31	81416100164	M20/122	23	81416102882	XXL/ 96	56
-	M20/ 5	31	81416100166	M20/123	23	81416102900	TGL/215	15
-	MLX/104	13	81416100167	M20/124	23	81416104071	F90/ 95	-
-	XXL/ 88	56	81416100191	M20/ 91	23	81416104072	F90/100	-
-	XXL/ 89	56	81416100221	MLX/ 95	46	81416104080	F90/ 95	-
2993918	240/670	19	81416100222	XXL/ 95	54	81416104113	M20/ 90	23
2993920	038/677	19	81416100223	TGL/ 90	15	81416104114	M20/ 90	23
4711230	M20/670	32	81416100224	TGL/ 95	15	81416104114	M20/990	25
4800248	038/677	19	81416100225	MLX/ 93	46	81416105294	F90/ 90	-
4821320	038/678	19	81416100226	MLX/ 92	46	81416105295	F90/ 95	-
41026756	240/655	19	81416100227	XXL/ 93	56	81416105296	F90/100	-
42541004	038/677	19	81416100228	XXL/ 92	56	81416105303	F90/ 95	-
98497961	038/677	19	81416100229	MLX/101	46	81416105376	M20/ 80	36
99430053	240/650	19	81416100230	MLX/100	46	81416105377	M20/ 85	36
500302656	240/670	19	81416100231	XXL/101	56	81416105378	M20/ 84	36
8146104066	F90/ 90	-	81416100232	XXL/100	56	81416105451	TGS/ 80	-
8162005013	MLX/550	13	81416100237	MLX/ 90	46	81416105453	M20/ 85	36
8162640657	M20/175	30	81416100238	XXL/ 90	54	81416105454	M20/ 84	36
8162640658	M20/174	30	81416100305	XXL/ 90	54	81416120018	TGL/ 96	15
8166410038	TGX/306	77	81416100306	XXL/ 95	54	81416120019	TGL/ 96	15
8166410038	TGX/307	77	81416100307	MLX/ 90	46	81416120021	TGL/145	-
81061026113	M20/ 81	-	81416100308	MLX/ 95	46	81416130050	M20/992	26
81062016020	XXL/142	-	81416100342	TGL/ 98	15	81416130051	M20/ 92	23
81122100039	M20/670	32	81416100343	TGL/ 99	15	81416130052	M20/ 94	23
81122100070	M20/670	32	81416100344	TGL/100	15	81416130056	M20/ 98	23
81122106027	M20/670	32	81416100345	TGL/101	15	81416130057	M20/ 99	23
81251016289	M20/601	-	81416100346	TGL/100	15	81416130058	M20/100	23
81251016290	M20/600	-	81416100347	TGL/101	15	81416130059	M20/101	23
81251016328	M20/700	-	81416100352	TGL/ 90	15	81416130066	M20/102	24
81251016329	M20/701	-	81416100359	TGL/ 95	15	81416130069	M20/103	24
81251016338	M20/700	-	81416100362	TGS/ 95	64	81416130071	M20/ 94	23
81251016339	M20/701	-	81416100364	TGX/ 90	74	81416130071	M20/994	27
81251016450	MLX/600	-	81416100365	TGS/ 97	64	81416130073	M20/ 92	23
81251016451	MLX/601	-	81416100366	TGS/ 96	64	81416130074	M20/992	26
81253206111	MLX/700	-	81416100369	TGX/101	74	81416130078	M20/ 98	23
81253206112	MLX/701	-	81416100370	TGX/100	74	81416130079	M20/ 99	23
81416100150	M20/ 97	23	81416100371	TGX/101	74	81416130080	M20/100	23
81416100151	M20/ 89	23	81416100372	TGX/100	74	81416130080	M20/101	23
81416100152	M20/ 88	23	81416100397	TGS/ 90	64	81416130081	M20/100	23

Cod. Originale O.E.M. Ref.	Cod. Covind Covind ref.	pag. Cat. page Cat.	Cod. Originale O.E.M. Ref.	Cod. Covind Covind ref.	pag. Cat. page Cat.	Cod. Originale O.E.M. Ref.	Cod. Covind Covind ref.	pag. Cat. page Cat.
81416130081	M20/101	23	81417015344	M20/116	-	81612300006	M20/316	29
81416135034	M20/ 95	24	81417015345	M20/115	-	81612300009	M20/317	29
81416135035	M20/ 95	24	81417226009	M20/106	-	81612300064	M20/316	29
81416140012	TGX/102	76	81417226010	M20/107	-	81612300065	M20/317	29
81416140019	TGL/219	-	81417226012	M20/106	-	81612300066	M20/316	29
81416140020	TGL/218	-	81417226013	M20/107	-	81612300067	M20/317	29
81416140027	TGS/ 93	64	81417226033	M20/106	-	81613102440	MLX/470	14
81416140028	TGS/ 92	64	81417226034	M20/107	-	81615100055	MLX/205	48
81416140029	TGX/ 93	76	81417226035	M20/107	-	81615100056	MLX/204	48
81416140030	TGX/ 92	76	81417226037	M20/106	-	81615100129	F90/241	-
81416140042	TGX/110	76	81418600058	M20/619	32	81615100130	F90/240	-
81416142117	TGX/ 94	76	81418600069	M20/619	32	81615100216	M20/210	29
81416142183	TGX/ 96	76	81418606110	TGX/619	79	81615100217	M20/211	29
81416144000	TGX/144	76	81426007287	M20/ 2	30	81615100223	M20/217	29
81416146003	TGX/111	76	81600007638	M20/900	22	81615100224	M20/216	29
81416146004	TGX/110	76	81600007795	MLX/900	12	81615100225	M20/241	38
81416155054	M20/ 96	24	81611100043	M20/150	28	81615100226	M20/240	38
81416155055	M20/ 96	24	81611100044	M20/150	28	81615100229	M20/245	29
81416155061	M20/ 96	24	81611100047	XXL/140	55	81615100230	M20/244	29
81416530007	M20/ 82	24	81611100053	XXL/140	55	81615100262	M20/216	29
81416530008	M20/ 83	24	81611100054	MLX/140	47	81615100263	M20/217	29
81416850013	TGX/ 89	76	81611100063	MLX/140	47	81615100267	M20/211	29
81416850029	TGL/ 85	15	81611100065	TGX/140	-	81615100268	M20/210	29
81416850031	MLX/ 82	46	81611100067	TGX/165	74	81615100271	TGS/208	65
81416850033	XXL/122	-	81611100068	TGX/164	74	81615100273	XXL/208	58
81416850040	MLX/ 80	46	81611106038	TGX/140	-	81615100280	XXL/200	58
81416850044	MLX/122	46	81611505060	M20/145	28	81615100281	XXL/201	58
81416850055	MLX/ 80	46	81611505066	XXL/145	55	81615100290	M20/240	38
81416850056	MLX/ 82	46	81611505068	MLX/145	47	81615100299	M20/241	38
81416850057	TGL/ 85	15	81611506049	MLX/145	47	81615100311	XXL/243	58
81416850058	TGL/ 80	15	81611506050	XXL/145	55	81615100312	XXL/242	58
81416850059	TGL/ 80	15	81611506051	MLX/145	47	81615100351	MLX/241	48
81416850073	TGX/ 99	76	81612100462	XXL/320	-	81615100355	MLX/245	48
81416850074	TGX/ 98	76	81612105090	OF7/205	-	81615100355	XXL/245	-
81416850094	TGS/124	64	81612105091	OF7/204	-	81615100372	XXL/242	56
81416850095	TGS/125	64	81612105112	OF7/205	-	81615100374	XXL/240	56
81416850096	TGX/124	76	81612105113	OF7/204	-	81615100380	MLX/240	48
81416850097	TGX/125	76	81612105218	OF7/205	-	81615100382	XXL/244	-
81416850112	TGX/ 88	76	81612105219	OF7/204	-	81615100399	XXL/201	58
81417015247	M20/115	-	81612105363	M20/203	29	81615100400	XXL/200	58
81417015248	M20/116	-	81612105364	M20/202	29	81615100401	TGX/201	75

Cod. Originale O.E.M. Ref.	Cod. Covind Covind ref.	pag. Cat. page Cat.	Cod. Originale O.E.M. Ref.	Cod. Covind Covind ref.	pag. Cat. page Cat.	Cod. Originale O.E.M. Ref.	Cod. Covind Covind ref.	pag. Cat. page Cat.
81615100401	XXL/199	56	81615100826	TGX/200	77	81625104611	MLX/246	13
81615100402	TGX/200	77	81615100853	MLX/201	48	81626004077	M20/ 3	30
81615100402	XXL/198	58	81615100854	MLX/200	48	81626004078	M20/ 2	30
81615100404	XXL/200	58	81615105152	M20/215	29	81626004082	M20/ 2	30
81615100421	XXL/212	58	81615105161	M20/199	29	81626004087	M20/ 3	30
81615100468	MLX/250	48	81615105162	M20/198	29	81626004088	M20/ 2	30
81615100470	TGS/198	65	81615105163	M20/201	29	81626004123	MLX/ 3	49
81615100490	TGS/208	65	81615105164	M20/200	29	81626004124	MLX/ 2	49
81615100536	MLX/250	48	81615105181	M20/215	29	81626004127	MLX/ 3	49
81615100562	TGL/244	18	81615105187	XXL/216	56	81626004128	MLX/ 2	49
81615100563	TGL/245	18	81615105191	M20/221	38	81626004135	MLX/ 3	49
81615100598	TGS/200	65	81615105192	M20/220	38	81626004136	MLX/ 2	49
81615100643	MLX/241	48	81615105194	M20/220	38	81626006237	M20/ 3	30
81615100644	MLX/240	48	81615105195	M20/221	38	81626007286	M20/ 3	30
81615100679	MLX/245	48	81615105196	M20/220	38	81626100018	XXL/ 4	58
81615100680	MLX/244	48	81615105197	M20/221	38	81626100019	XXL/ 5	58
81615100703	XXL/201	56	81615110000	TGS/212	65	81626100023	XXL/ 7	58
81615100704	TGX/204	75	81615110000	XXL/212	56	81626100024	XXL/ 6	58
81615100704	XXL/200	56	81615110001	TGS/212	65	81626100040	XXL/ 6	58
81615100705	XXL/199	56	81615110001	XXL/212	56	81626300047	M20/ 21	30
81615100724	TGX/204	77	81616100333	XXL/241	56	81626300048	M20/ 20	30
81615100735	MLX/241	48	81616100334	XXL/240	56	81626306020	M20/ 14	30
81615100736	MLX/240	48	81618516011	M20/134	-	81626306021	M20/ 15	30
81615100739	MLX/245	48	81618516019	M20/134	-	81626406055	M20/173	30
81615100740	MLX/244	48	81618516020	M20/134	-	81626406056	M20/172	30
81615100747	XXL/243	58	81618516023	M20/134	-	81626410099	M20/171	30
81615100751	XXL/241	58	81624100046	XXL/160	57	81626410100	M20/170	30
81615100752	XXL/240	56	81624100047	XXL/161	57	81626410101	M20/ 16	30
81615100757	TGS/199	65	81624100048	XXL/162	57	81626416052	M20/197	30
81615100758	TGS/198	65	81624100049	XXL/163	57	81626416067	XXL/173	59
81615100761	TGS/201	65	81624100063	M20/165	28	81626416068	XXL/172	59
81615100762	TGS/200	65	81624100064	M20/164	28	81626416078	XXL/174	59
81615100801	XXL/241	56	81624100065	M20/165	28	81626416079	XXL/175	59
81615100802	XXL/240	56	81624100066	M20/164	28	81626416080	XXL/174	59
81615100810	TGL/244	18	81624102224	M20/160	28	81626416081	XXL/175	59
81615100811	TGL/245	18	81624102225	M20/161	28	81626705004	M20/ 7	30
81615100820	TGL/200	18	81624102262	M20/160	28	81626706011	M20/ 7	30
81615100821	TGL/201	18	81624102263	M20/161	28	81626800055	M20/185	30
81615100823	MLX/250	48	81625104564	MLX/246	13	81626800059	M20/190	-
81615100824	TGX/204	77	81625104565	MLX/247	13	81626800060	M20/187	30
81615100825	TGX/205	77	81625104607	MLX/247	13	81626800061	M20/179	-

Cod. Originale O.E.M. Ref.	Cod. Covind Covind ref.	pag. Cat. page Cat.	Cod. Originale O.E.M. Ref.	Cod. Covind Covind ref.	pag. Cat. page Cat.	Cod. Originale O.E.M. Ref.	Cod. Covind Covind ref.	pag. Cat. page Cat.
81626800062	M20/178	-	81664100173	XXL/519	59	81664106652	TGX/515	-
81626800072	M20/178	-	81664100183	XXL/320	-	81664106653	TGX/541	-
81626800073	M20/179	-	81664100226	XXL/515	60	81664106654	TGX/542	-
81626800074	M20/187	30	81664100293	XXL/517	60	81664400187	TGX/509	-
81626800084	M20/176	-	81664100294	XXL/516	60	81664400189	TGX/505	78
81626800085	M20/177	-	81664100299	XXL/517	60	81664400193	TGX/500	78
81626800086	M20/188	-	81664100306	TGX/206	77	81669120033	M20/251	29
81626800087	M20/189	-	81664100307	TGX/207	77	81669120034	M20/250	29
81626806095	M20/183	30	81664100352	M20/320	29	81669120035	M20/256	-
81626806096	M20/182	30	81664100353	M20/321	29	81669120036	M20/253	-
81626806097	M20/181	30	81664100486	TGX/511	-	81669120059	M20/256	-
81626806098	M20/180	30	81664100487	TGX/510	-	81669120077	M20/251	29
81626806107	M20/181	30	81664106086	XXL/520	59	81669120078	M20/250	29
81626806108	M20/180	30	81664106088	XXL/520	59	81748210095	M20/146	28
81626906049	MLX/ 7	49	81664106599	TGX/516	78	81907120032	M20/105	-
81626906050	MLX/ 6	49	81664106600	TGX/519	80	81955016317	M20/255	-
81626906063	MLX/ 9	49	81664106601	TGX/512	-	81955016364	M20/255	-
81626906064	MLX/ 8	49	81664106602	TGX/521	-	81955016367	M20/255	-
81626910010	M20/ 8	30	81664106603	TGX/517	78	81955016372	M20/255	-
81626925001	M20/ 9	30	81664106604	TGX/518	-	81960020466	MLX/ 85	46
81627104213	M20/315	-	81664106605	TGX/514	-	81960020491	MLX/ 85	46
81627104318	MLX/300	14	81664106606	TGX/520	78	81960020497	MLX/ 85	46
81628104499	MLX/449	14	81664106607	TGX/530	79	81961210055	M20/800	28
81628104500	MLX/448	14	81664106608	TGX/513	80	81961210056	M20/800	28
81628114823	MLX/475	14	81664106609	TGX/540	78	81971006079	M20/194	31
81629102290	M20/370	-	81664106610	TGX/545	-	81971006094	M20/196	31
81629102578	M20/370	-	81664106611	TGX/550	-	81971006098	M20/196	31
81629104315	MLX/370	14	81664106612	TGX/525	80	81971006099	M20/194	31
81629416038	M20/375	22	81664106625	TGX/543	80	81971220008	M20/252	-
81637306303	M20/500	-	81664106626	TGX/533	-	81971220028	M20/252	-
81637306305	M20/503	-	81664106627	TGX/534	-	81972010229	M20/254	-
81637306314	M20/501	-	81664106628	TGX/535	-	85200013946	M20/619	32
81637306316	M20/502	-	81664106629	TGX/529	-	85200013978	M20/619	32
81637306367	M20/502	-	81664106630	TGX/528	-	99100760008	M20/619	32
81637306368	M20/503	-	81664106631	TGX/532	-			
81637450016	M20/ 11	30	81664106632	TGX/536	-			
81637450017	M20/ 10	30	81664106633	TGX/537	-			
81664100125	M20/321	29	81664106638	TGX/511	-			
81664100126	M20/320	29	81664106639	TGX/510	-			
81664100169	XXL/517	59	81664106640	TGX/538	-			
81664100172	XXL/518	59	81664106651	TGX/522	-			

Cod. Covind Covind ref.	Cod. Originale O.E.M. Ref.	pag. Cat. page Cat.	Cod. Covind Covind ref.	Cod. Originale O.E.M. Ref.	pag. Cat. page Cat.	Cod. Covind Covind ref.	Cod. Originale O.E.M. Ref.	pag. Cat. page Cat.
038/677	2993920	19	M20/ 10	81637450017	30	M20/101	81416130081	23
038/677	4800248	19	M20/ 11	81637450016	30	M20/102	81416130066	24
038/677	42541004	19	M20/ 14	81626306020	30	M20/103	81416130069	24
038/677	98497961	19	M20/ 15	81626306021	30	M20/105	81907120032	-
038/678	4821320	19	M20/ 16	81626410101	30	M20/106	81417226009	-
0F7/204	81612105091	-	M20/ 20	81626300048	30	M20/106	81417226012	-
0F7/204	81612105113	-	M20/ 21	81626300047	30	M20/106	81417226033	-
0F7/204	81612105219	-	M20/ 80	81416105376	36	M20/106	81417226037	-
0F7/205	81612105090	-	M20/ 81	81061026113	-	M20/107	81417226010	-
0F7/205	81612105112	-	M20/ 82	81416530007	24	M20/107	81417226013	-
0F7/205	81612105218	-	M20/ 83	81416530008	24	M20/107	81417226034	-
240/650	99430053	19	M20/ 84	81416105454	36	M20/107	81417226035	-
240/655	41026756	19	M20/ 84	81416105378	36	M20/115	81417015247	-
240/670	2993918	19	M20/ 85	81416105453	36	M20/115	81417015345	-
240/670	500302656	19	M20/ 85	81416105377	36	M20/116	81417015248	-
940/950	-	54	M20/ 86	81416100158	23	M20/116	81417015344	-
940/960	-	54	M20/ 87	81416100159	23	M20/122	81416100164	23
F90/ 90	8146104066	-	M20/ 88	81416100152	23	M20/123	81416100166	23
F90/ 90	81416105294	-	M20/ 89	81416100151	23	M20/124	81416100167	23
F90/ 95	81416104071	-	M20/ 90	81416104113	23	M20/134	81618516011	-
F90/ 95	81416104080	-	M20/ 90	81416104114	23	M20/134	81618516019	-
F90/ 95	81416105295	-	M20/ 91	81416100191	23	M20/134	81618516020	-
F90/ 95	81416105303	-	M20/ 92	81416130051	23	M20/134	81618516023	-
F90/100	81416104072	-	M20/ 92	81416130073	23	M20/145	81611505060	28
F90/100	81416105296	-	M20/ 94	81416130052	23	M20/146	81748210095	28
F90/240	81615100130	-	M20/ 94	81416130071	23	M20/150	81611100043	28
F90/241	81615100129	-	M20/ 95	81416135034	24	M20/150	81611100044	28
M20/ 2	81426007287	30	M20/ 95	81416135035	24	M20/160	81624102224	28
M20/ 2	81626004078	30	M20/ 96	81416155054	24	M20/160	81624102262	28
M20/ 2	81626004082	30	M20/ 96	81416155055	24	M20/161	81624102225	28
M20/ 2	81626004088	30	M20/ 96	81416155061	24	M20/161	81624102263	28
M20/ 3	81626004077	30	M20/ 97	81416100150	23	M20/164	81624100064	28
M20/ 3	81626004087	30	M20/ 98	81416130078	23	M20/164	81624100066	28
M20/ 3	81626006237	30	M20/ 98	81416130056	23	M20/165	81624100063	28
M20/ 3	81626007286	30	M20/ 99	81416130079	23	M20/165	81624100065	28
M20/ 4	-	31	M20/ 99	81416130057	23	M20/170	81626410100	30
M20/ 5	-	31	M20/100	81416130058	23	M20/171	81626410099	30
M20/ 7	81626705004	30	M20/100	81416130080	23	M20/172	81626406056	30
M20/ 7	81626706011	30	M20/100	81416130081	23	M20/173	81626406055	30
M20/ 8	81626910010	30	M20/101	81416130059	23	M20/174	8162640658	30
M20/ 9	81626925001	30	M20/101	81416130080	23	M20/175	8162640657	30

Cod. Covind Covind ref.	Cod. Originale O.E.M. Ref.	pag. Cat. page Cat.	Cod. Covind Covind ref.	Cod. Originale O.E.M. Ref.	pag. Cat. page Cat.	Cod. Covind Covind ref.	Cod. Originale O.E.M. Ref.	pag. Cat. page Cat.
M20/176	81626800084	-	M20/220	81615105196	38	M20/502	81637306367	-
M20/177	81626800085	-	M20/221	81615105191	38	M20/503	81637306305	-
M20/178	81626800062	-	M20/221	81615105195	38	M20/503	81637306368	-
M20/178	81626800072	-	M20/221	81615105197	38	M20/600	81251016290	-
M20/179	81626800061	-	M20/240	81615100226	38	M20/601	81251016289	-
M20/179	81626800073	-	M20/240	81615100290	38	M20/619	81418600058	32
M20/180	81626806098	30	M20/241	81615100225	38	M20/619	81418600069	32
M20/180	81626806108	30	M20/241	81615100299	38	M20/619	85200013946	32
M20/181	81626806097	30	M20/244	81615100230	29	M20/619	85200013978	32
M20/181	81626806107	30	M20/245	81615100229	29	M20/619	99100760008	32
M20/182	81626806096	30	M20/250	81669120034	29	M20/670	81122100039	32
M20/183	81626806095	30	M20/250	81669120078	29	M20/670	81122100070	32
M20/185	81626800055	30	M20/251	81669120033	29	M20/670	81122106027	32
M20/187	81626800060	30	M20/251	81669120077	29	M20/670	4711230	32
M20/187	81626800074	30	M20/252	81971220008	-	M20/700	81251016328	-
M20/188	81626800086	-	M20/252	81971220028	-	M20/700	81251016338	-
M20/189	81626800087	-	M20/253	81669120036	-	M20/701	81251016329	-
M20/190	81626800059	-	M20/254	81972010229	-	M20/701	81251016339	-
M20/194	81971006079	31	M20/255	81955016317	-	M20/800	81961210055	28
M20/194	81971006099	31	M20/255	81955016364	-	M20/800	81961210056	28
M20/196	81971006094	31	M20/255	81955016367	-	M20/900	81600007638	22
M20/196	81971006098	31	M20/255	81955016372	-	M20/990	81416104114	25
M20/197	81626416052	30	M20/256	81669120035	-	M20/992	81416130050	26
M20/198	81615105162	29	M20/256	81669120059	-	M20/992	81416130074	26
M20/199	81615105161	29	M20/315	81627104213	-	M20/994	81416130071	27
M20/200	81615105164	29	M20/316	81612300006	29	MLX/ 2	81626004124	49
M20/201	81615105163	29	M20/316	81612300064	29	MLX/ 2	81626004128	49
M20/202	81612105364	29	M20/316	81612300066	29	MLX/ 2	81626004136	49
M20/203	81612105363	29	M20/317	81612300009	29	MLX/ 3	81626004123	49
M20/210	81615100216	29	M20/317	81612300065	29	MLX/ 3	81626004127	49
M20/210	81615100268	29	M20/317	81612300067	29	MLX/ 3	81626004135	49
M20/211	81615100217	29	M20/320	81664100126	29	MLX/ 6	81626906050	49
M20/211	81615100267	29	M20/320	81664100352	29	MLX/ 7	81626906049	49
M20/215	81615105152	29	M20/321	81664100125	29	MLX/ 8	81626906064	49
M20/215	81615105181	29	M20/321	81664100353	29	MLX/ 9	81626906063	49
M20/216	81615100224	29	M20/370	81629102290	-	MLX/ 80	81416850040	46
M20/216	81615100262	29	M20/370	81629102578	-	MLX/ 80	81416850055	46
M20/217	81615100223	29	M20/375	81629416038	22	MLX/ 82	81416850031	46
M20/217	81615100263	29	M20/500	81637306303	-	MLX/ 82	81416850056	46
M20/220	81615105192	38	M20/501	81637306314	-	MLX/ 85	81960020466	46
M20/220	81615105194	38	M20/502	81637306316	-	MLX/ 85	81960020491	46

Cod. Covind Covind ref.	Cod. Originale O.E.M. Ref.	pag. Cat. page Cat.	Cod. Covind Covind ref.	Cod. Originale O.E.M. Ref.	pag. Cat. page Cat.	Cod. Covind Covind ref.	Cod. Originale O.E.M. Ref.	pag. Cat. page Cat.
MLX/ 85	81960020497	46	MLX/449	81628104499	14	TGS/ 97	81416100365	64
MLX/ 90	81416100237	46	MLX/470	81613102440	14	TGS/124	81416850094	64
MLX/ 90	81416100307	46	MLX/475	81628114823	14	TGS/125	81416850095	64
MLX/ 92	81416100226	46	MLX/550	8162005013	13	TGS/198	81615100758	65
MLX/ 93	81416100225	46	MLX/600	81251016450	-	TGS/198	81615100470	65
MLX/ 95	81416100221	46	MLX/601	81251016451	-	TGS/199	81615100757	65
MLX/ 95	81416100308	46	MLX/700	81253206111	-	TGS/200	81615100762	65
MLX/100	81416100230	46	MLX/701	81253206112	-	TGS/200	81615100598	65
MLX/101	81416100229	46	MLX/900	81600007795	12	TGS/201	81615100761	65
MLX/104	-	13	TGL/ 80	81416850058	15	TGS/208	81615100490	65
MLX/122	81416850044	46	TGL/ 80	81416850059	15	TGS/208	81615100271	65
MLX/140	81611100054	47	TGL/ 85	81416850029	15	TGS/212	81615110001	65
MLX/140	81611100063	47	TGL/ 85	81416850057	15	TGS/212	81615110000	65
MLX/145	81611505068	47	TGL/ 90	81416100223	15	TGX/ 88	81416850112	76
MLX/145	81611506049	47	TGL/ 90	81416100352	15	TGX/ 89	81416850013	76
MLX/145	81611506051	47	TGL/ 95	81416100359	15	TGX/ 90	81416100364	76
MLX/200	81615100854	48	TGL/ 95	81416100224	15	TGX/ 92	81416140030	76
MLX/201	81615100853	48	TGL/ 96	81416120018	15	TGX/ 93	81416140029	76
MLX/204	81615100056	54	TGL/ 96	81416120019	15	TGX/ 94	81416142117	76
MLX/205	81615100055	54	TGL/ 98	81416100342	15	TGX/ 96	81416142183	76
MLX/240	81615100380	48	TGL/ 99	81416100343	15	TGX/ 98	81416850074	76
MLX/240	81615100736	48	TGL/100	81416100344	15	TGX/ 99	81416850073	76
MLX/240	81615100644	48	TGL/100	81416100346	15	TGX/100	81416100372	76
MLX/241	81615100351	48	TGL/101	81416100345	15	TGX/100	81416100370	76
MLX/241	81615100735	48	TGL/101	81416100347	15	TGX/101	81416100371	76
MLX/241	81615100643	48	TGL/145	81416120021	-	TGX/101	81416100369	76
MLX/244	81615100740	48	TGL/200	81615100820	18	TGX/102	81416140012	76
MLX/244	81615100680	48	TGL/201	81615100821	18	TGX/110	81416146004	76
MLX/245	81615100355	48	TGL/215	81416102900	15	TGX/110	81416140042	76
MLX/245	81615100739	48	TGL/218	81416140020	-	TGX/111	81416146003	76
MLX/245	81615100679	48	TGL/219	81416140019	-	TGX/124	81416850096	76
MLX/246	81625104564	13	TGL/244	81615100810	18	TGX/125	81416850097	76
MLX/246	81625104611	13	TGL/244	81615100562	18	TGX/140	81611100065	-
MLX/247	81625104565	13	TGL/245	81615100811	18	TGX/140	81611106038	-
MLX/247	81625104607	13	TGL/245	81615100563	18	TGX/144	81416144000	76
MLX/250	81615100468	48	TGS/ 80	81416105451	-	TGX/164	81611100068	76
MLX/250	81615100536	48	TGS/ 90	81416100397	64	TGX/165	81611100067	76
MLX/250	81615100823	48	TGS/ 92	81416140028	64	TGX/200	81615100402	77
MLX/300	81627104318	14	TGS/ 93	81416140027	64	TGX/200	81615100826	77
MLX/370	81629104315	14	TGS/ 95	81416100362	64	TGX/201	81615100401	77
MLX/448	81628104500	14	TGS/ 96	81416100366	64	TGX/204	81615100824	77

Cod. Covind Covind ref.	Cod. Originale O.E.M. Ref.	pag. Cat. page Cat.	Cod. Covind Covind ref.	Cod. Originale O.E.M. Ref.	pag. Cat. page Cat.	Cod. Covind Covind ref.	Cod. Originale O.E.M. Ref.	pag. Cat. page Cat.
TGX/204	81615100704	77	TGX/550	81664106611	-	XXL/200	81615100404	58
TGX/204	81615100724	77	TGX/619	81418606110	81	XXL/200	81615100704	58
TGX/205	81615100825	77	XXL/ 4	81626100018	58	XXL/201	81615100281	58
TGX/206	81664100306	77	XXL/ 5	81626100019	58	XXL/201	81615100399	58
TGX/207	81664100307	77	XXL/ 6	81626100040	58	XXL/201	81615100703	58
TGX/306	8166410038	77	XXL/ 6	81626100024	58	XXL/208	81615100273	58
TGX/307	8166410038	77	XXL/ 7	81626100023	58	XXL/212	81615100421	58
TGX/500	81664400193	78	XXL/ 88	-	54	XXL/212	81615110000	58
TGX/505	81664400189	78	XXL/ 89	-	54	XXL/212	81615110001	58
TGX/509	81664400187	-	XXL/ 90	81416100238	54	XXL/216	81615105187	58
TGX/510	81664100487	-	XXL/ 90	81416100305	54	XXL/240	81615100374	58
TGX/510	81664106639	-	XXL/ 90	81416100405	54	XXL/240	81615100752	58
TGX/511	81664100486	-	XXL/ 92	81416100228	54	XXL/240	81615100802	58
TGX/511	81664106638	-	XXL/ 93	81416100227	54	XXL/240	81616100334	58
TGX/512	81664106601	-	XXL/ 95	81416100222	56	XXL/241	81615100801	58
TGX/513	81664106608	80	XXL/ 95	81416100306	54	XXL/241	81615100751	58
TGX/514	81664106605	-	XXL/ 96	81416102882	54	XXL/241	81616100333	58
TGX/515	81664106652	-	XXL/ 97	81416102881	54	XXL/242	81615100312	58
TGX/516	81664106599	78	XXL/100	81416100232	54	XXL/242	81615100372	58
TGX/517	81664106603	78	XXL/101	81416100231	54	XXL/243	81615100311	58
TGX/518	81664106604	-	XXL/122	81416850033	-	XXL/243	81615100747	58
TGX/519	81664106600	80	XXL/140	81611100047	57	XXL/244	81615100382	-
TGX/520	81664106606	78	XXL/140	81611100053	57	XXL/245	81615100355	-
TGX/521	81664106602	-	XXL/142	81062016020	-	XXL/320	81612100462	-
TGX/522	81664106651	-	XXL/145	81611505066	57	XXL/320	81664100183	-
TGX/525	81664106612	80	XXL/145	81611506050	57	XXL/515	81664100226	60
TGX/528	81664106630	-	XXL/160	81624100046	57	XXL/516	81664100294	60
TGX/529	81664106629	-	XXL/161	81624100047	57	XXL/517	81664100169	60
TGX/530	81664106607	79	XXL/162	81624100048	57	XXL/517	81664100293	60
TGX/532	81664106631	-	XXL/163	81624100049	57	XXL/517	81664100299	60
TGX/533	81664106626	-	XXL/172	81626416068	59	XXL/518	81664100172	60
TGX/534	81664106627	-	XXL/173	81626416067	59	XXL/519	81664100173	60
TGX/535	81664106628	-	XXL/174	81626416078	59	XXL/520	81664106086	60
TGX/536	81664106632	-	XXL/174	81626416080	59	XXL/520	81664106088	60
TGX/537	81664106633	-	XXL/175	81626416079	58			
TGX/538	81664106640	-	XXL/175	81626416081	58			
TGX/540	81664106609	80	XXL/198	81615100402	58			
TGX/541	81664106653	-	XXL/199	81615100401	58			
TGX/542	81664106654	-	XXL/199	81615100705	58			
TGX/543	81664106625	79	XXL/200	81615100280	58			
TGX/545	81664106610	-	XXL/200	81615100400	58			

MAN

MAN TGL



11

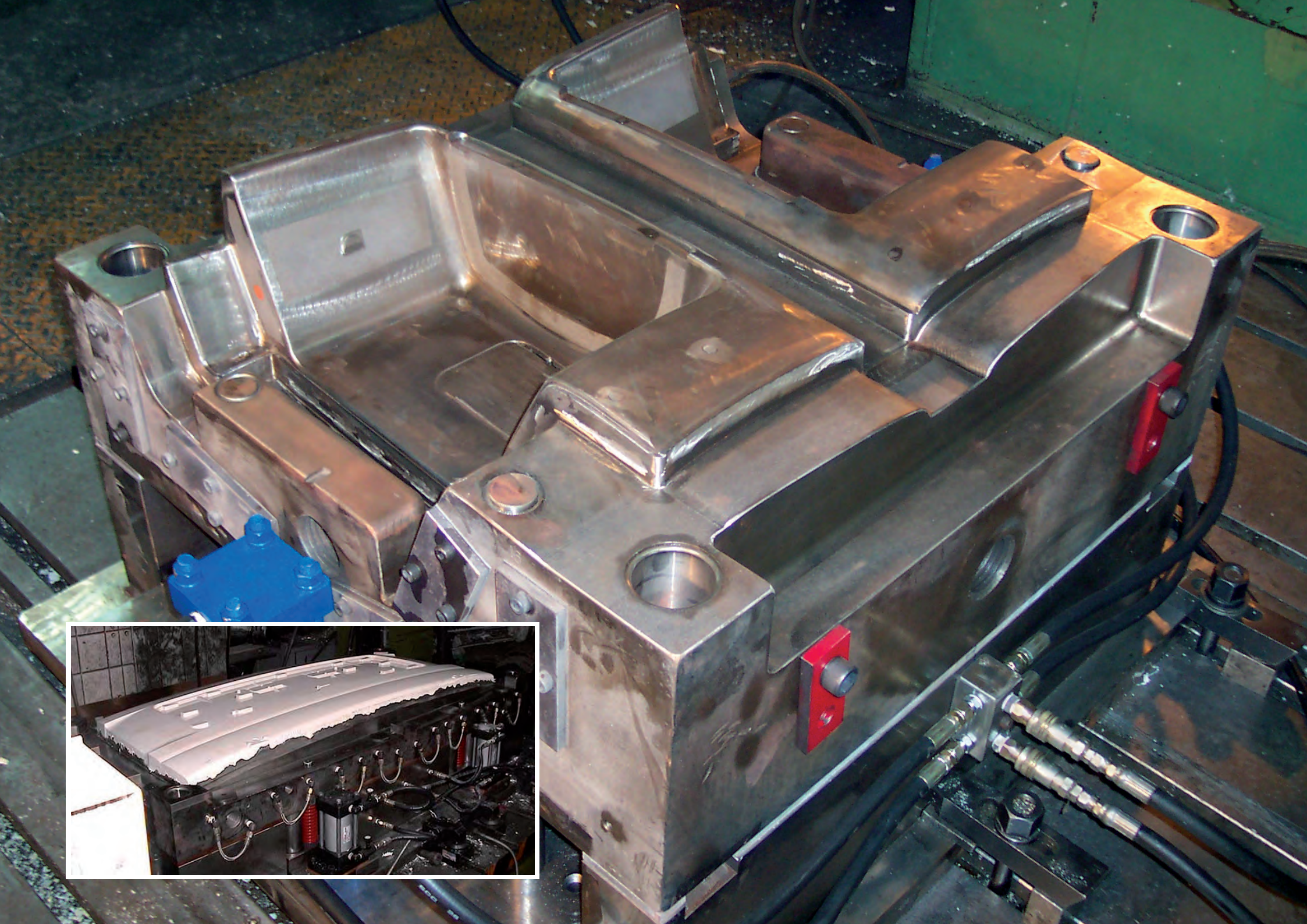

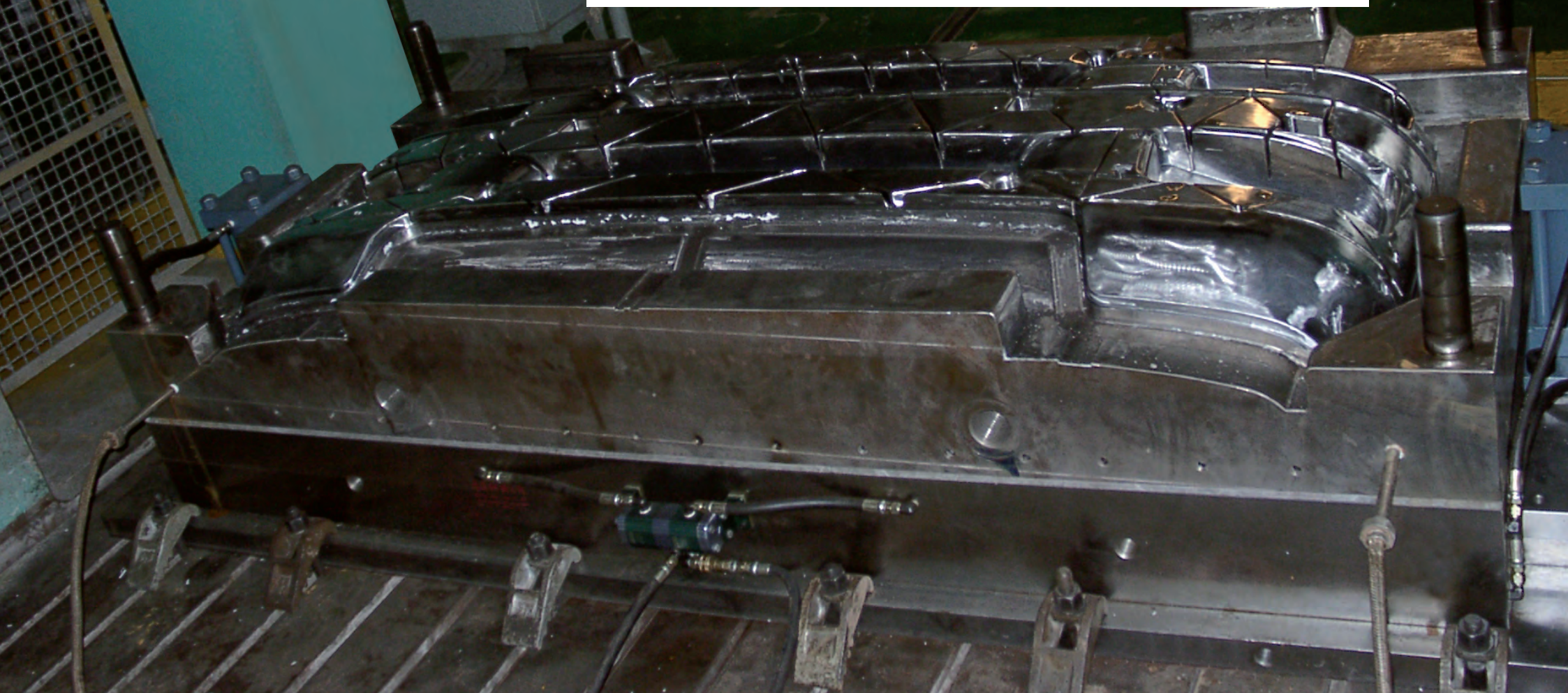
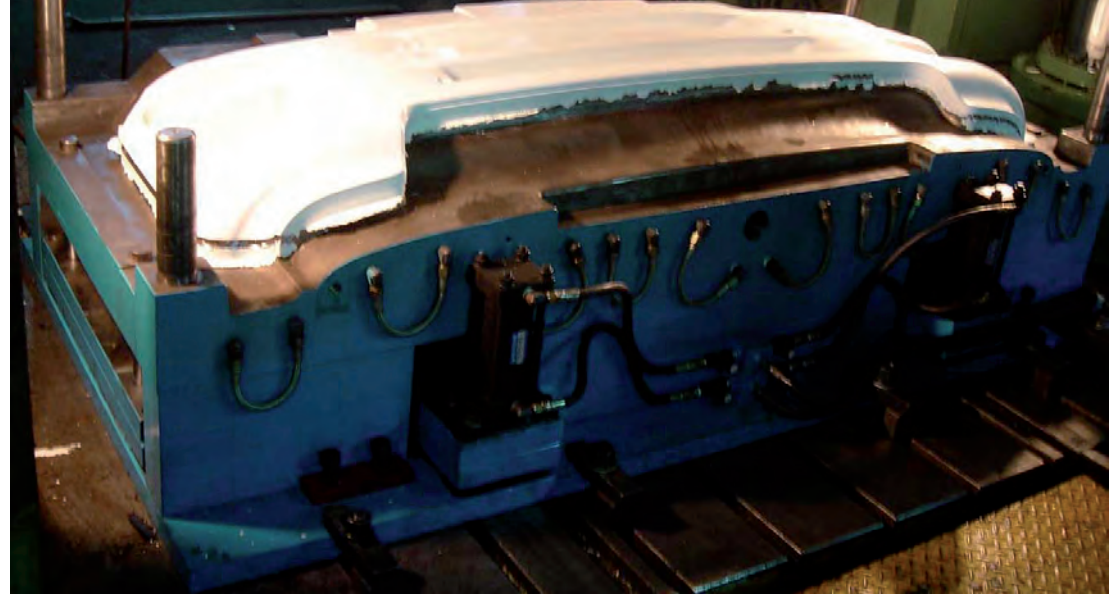



- (°) Verniciato grigio
- (°) Grey painted
- (°) grau strukturlackiert

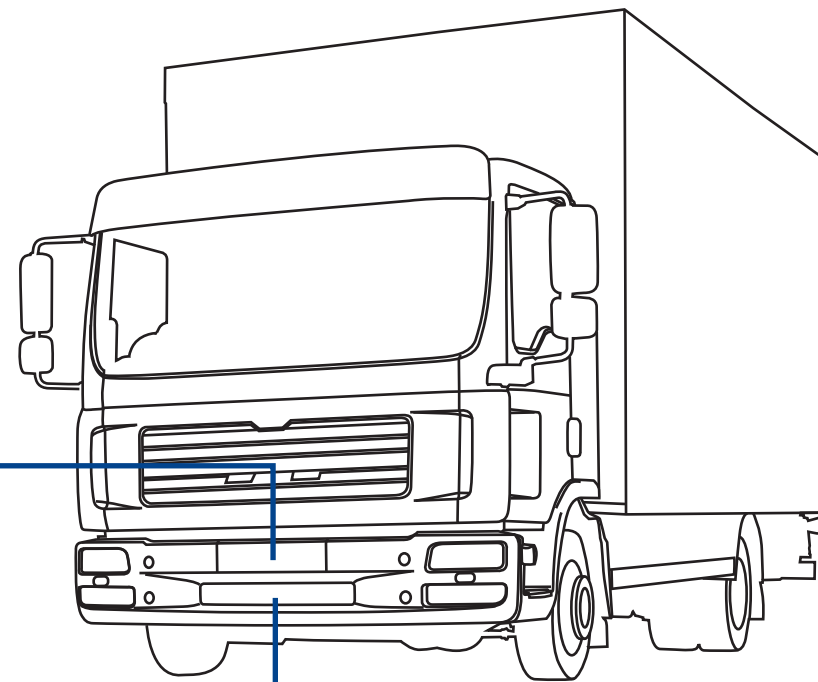
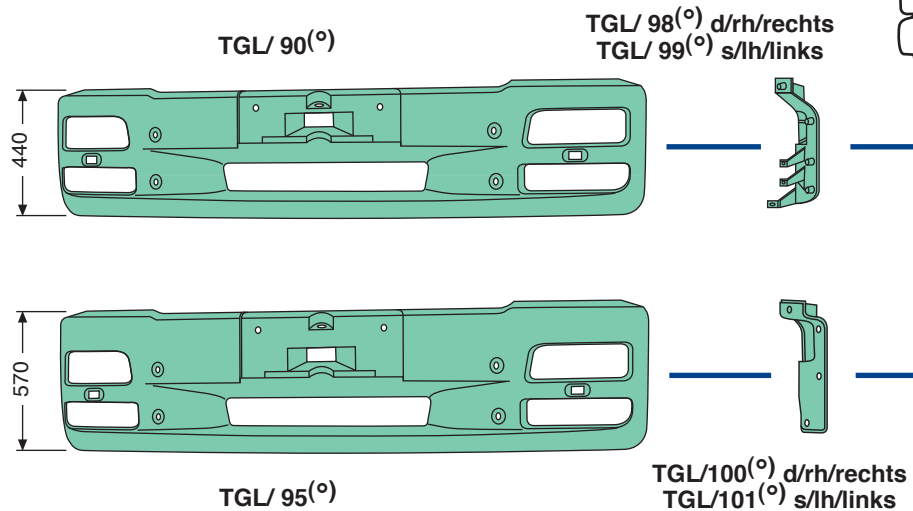
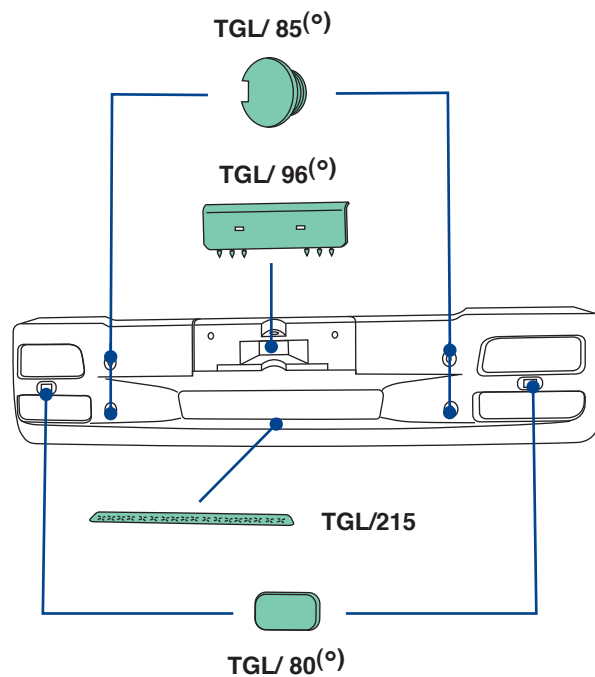

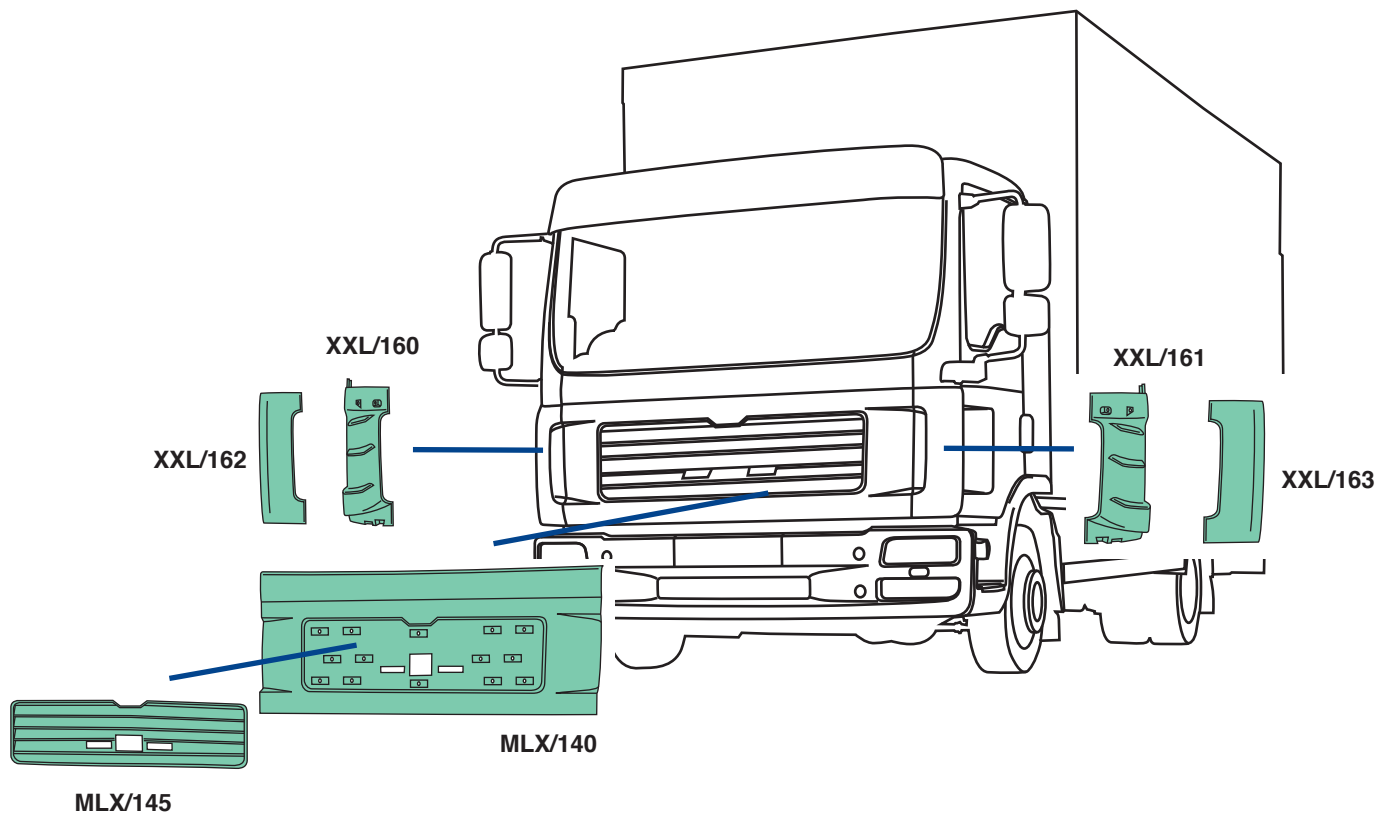

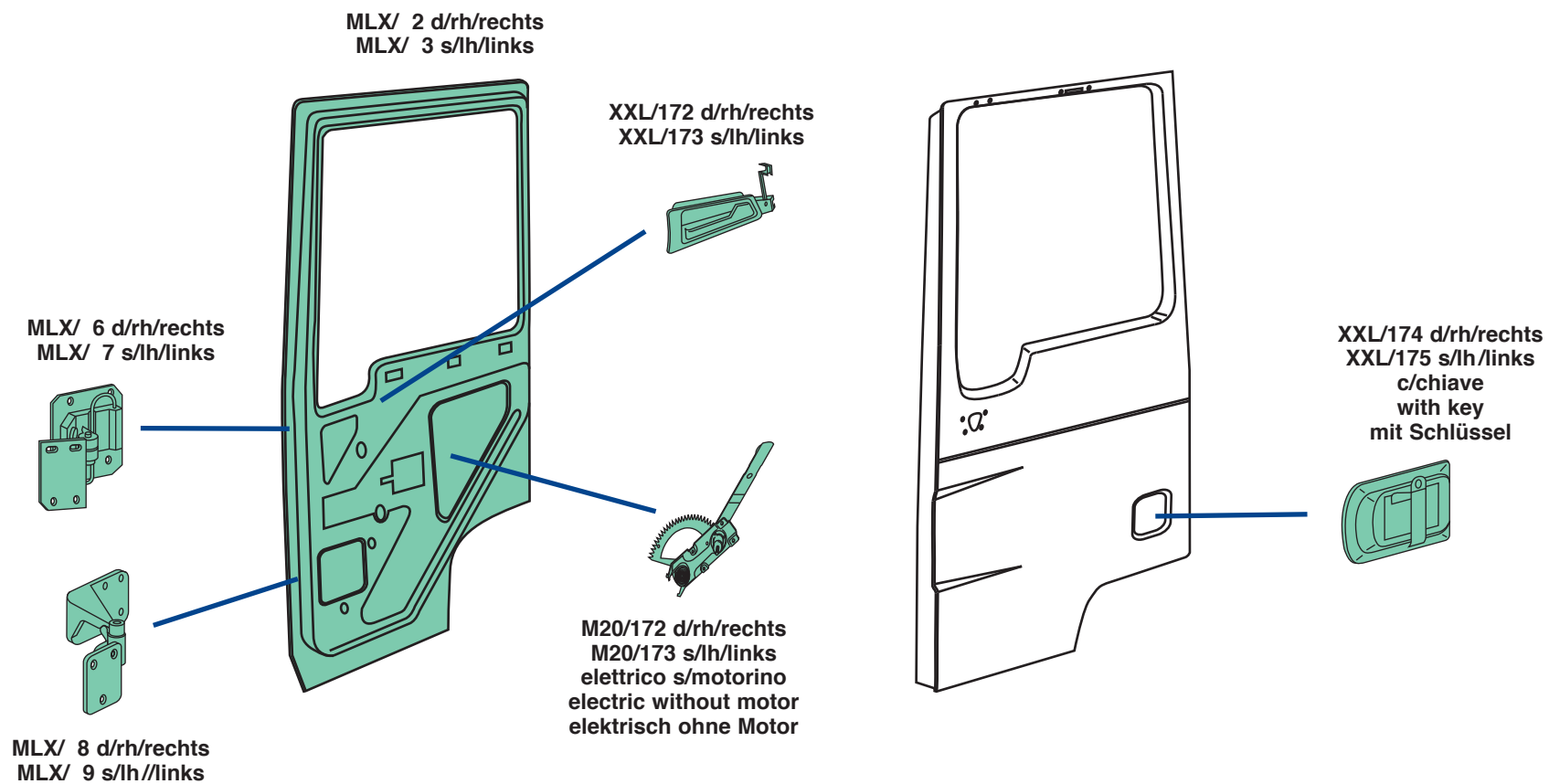

- (°) Verniciato grigio
- (°) Grey painted
- (°) grau strukturlackiert

18

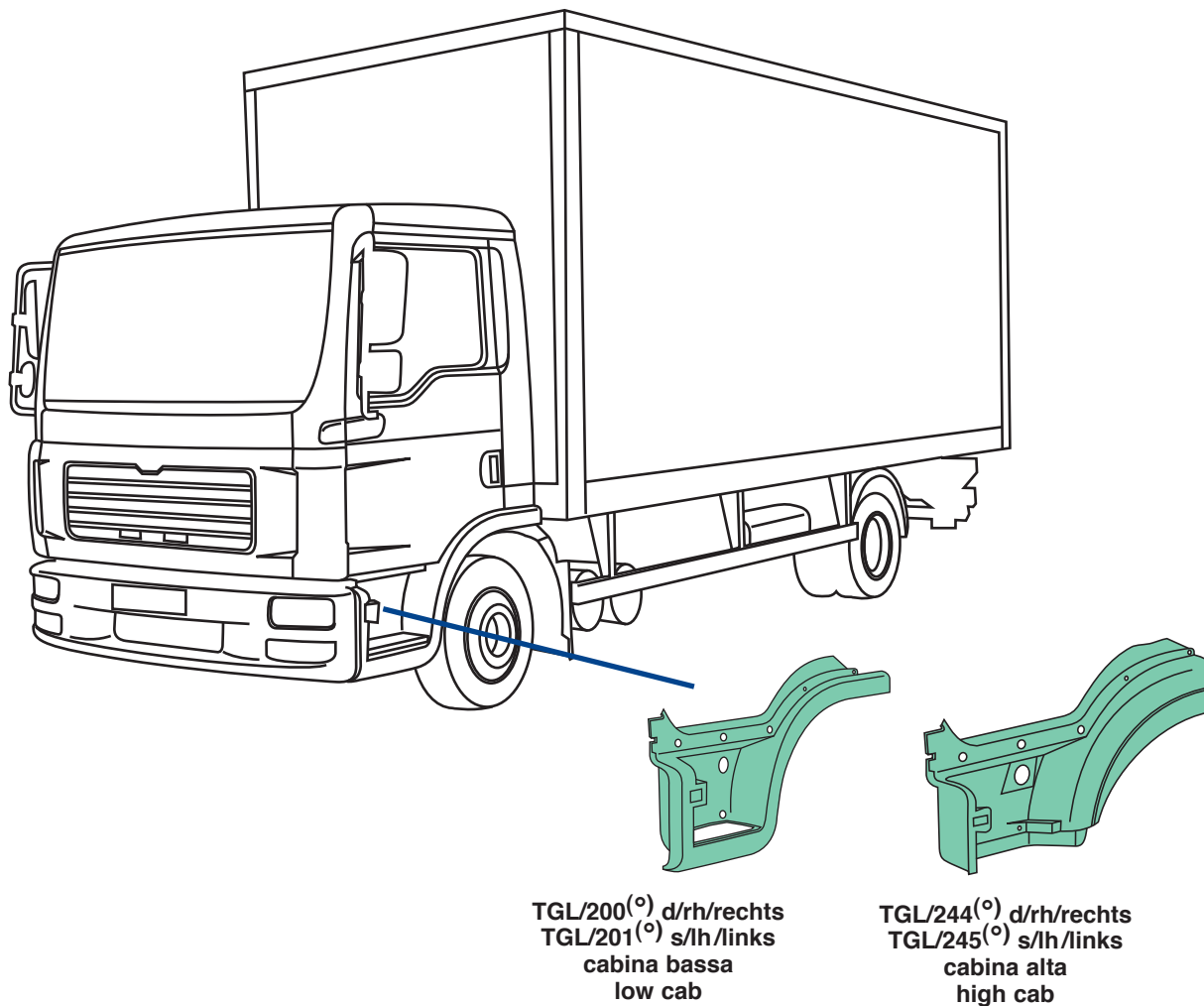

M20/670

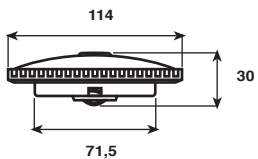

038/677

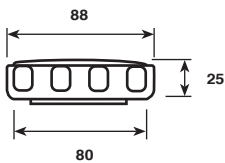

038/678

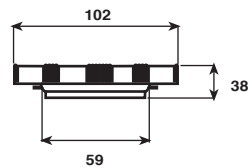

240/677

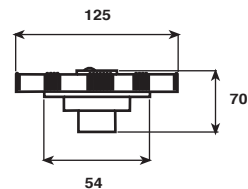

M20/670
con chiave
with key
mit Schlüssel



240/677
con chiave
with key
mit Schlüssel



038/677
sostituito da
replaced by
ersetzt durch
038/678



038/678
senza chiave
without key
ohne Schlüssel

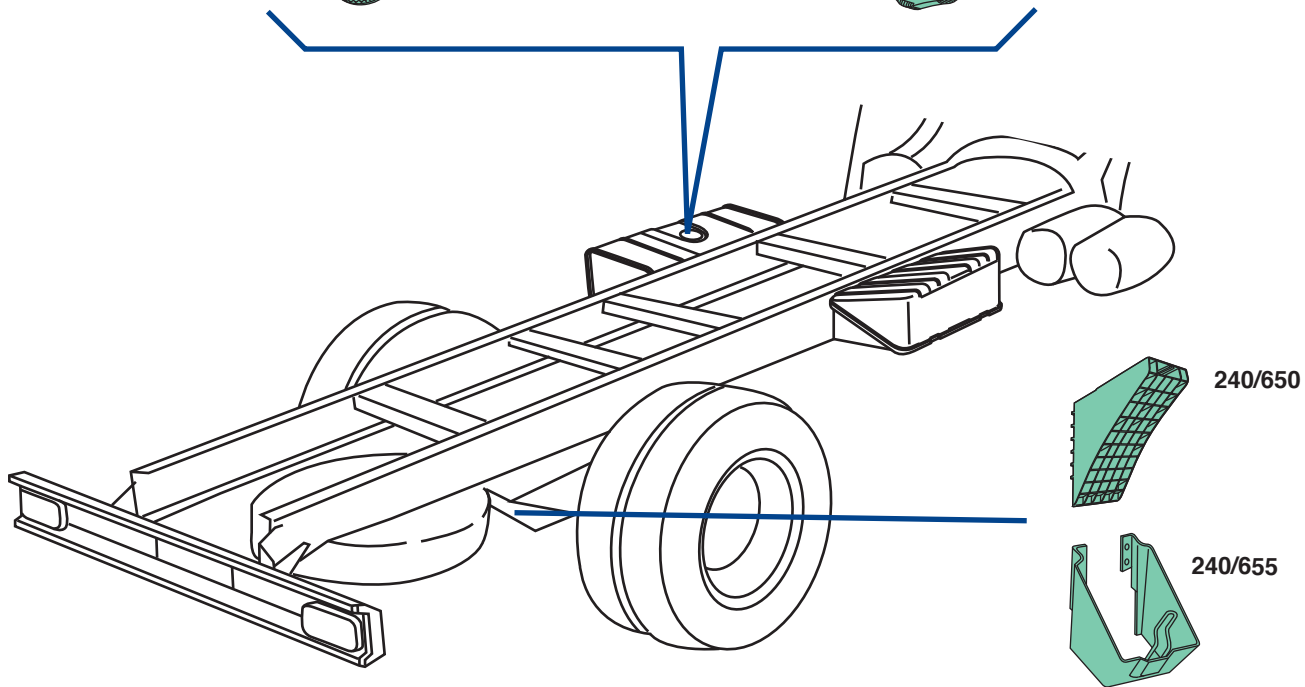
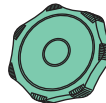



COVIND

MAN

MAN F2000

19-343/19-463/26-463



21

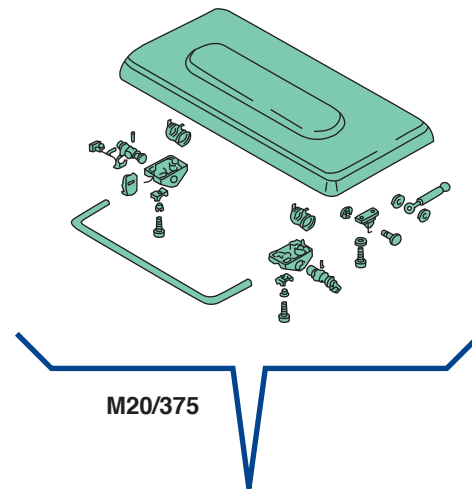

M20/900

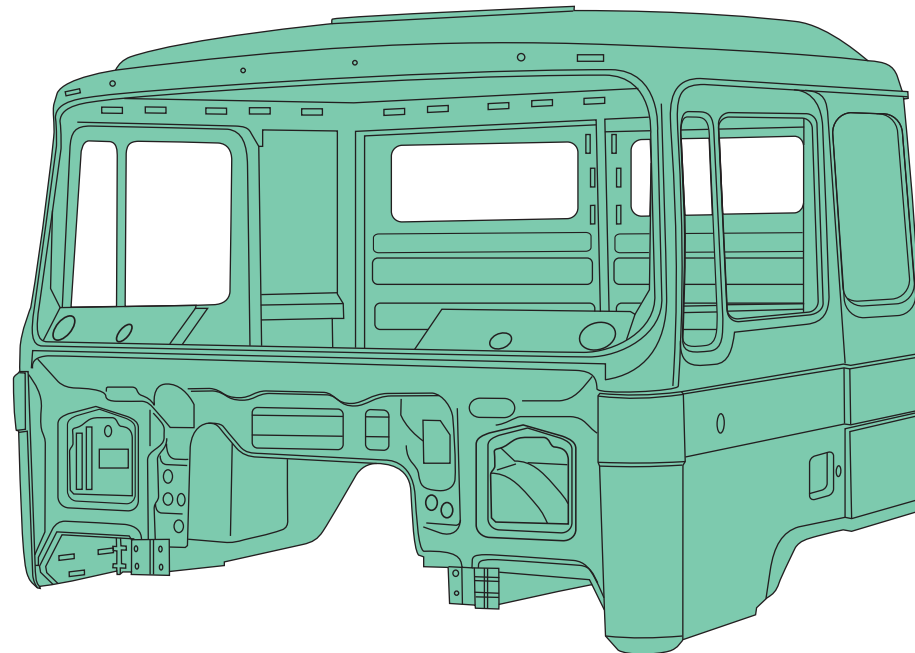

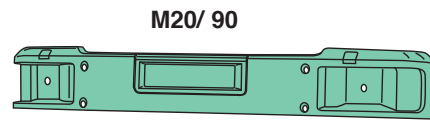
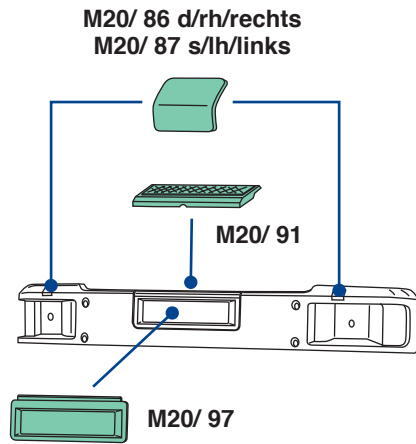

M20/ 88 d/rh/rechts
M20/ 89 s/lh/links

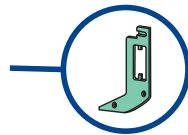

M20/ 92
250 mm

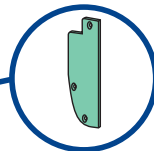
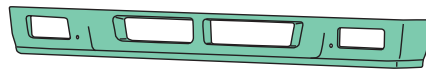

M20/ 98 d/rh/rechts
M20/ 99 s/lh/links

M20/ 94
350 mm

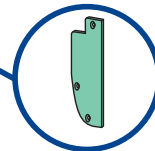
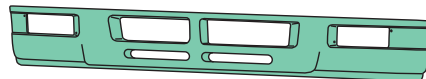

M20/100 d/rh/rechts
M20/101 s/lh/links

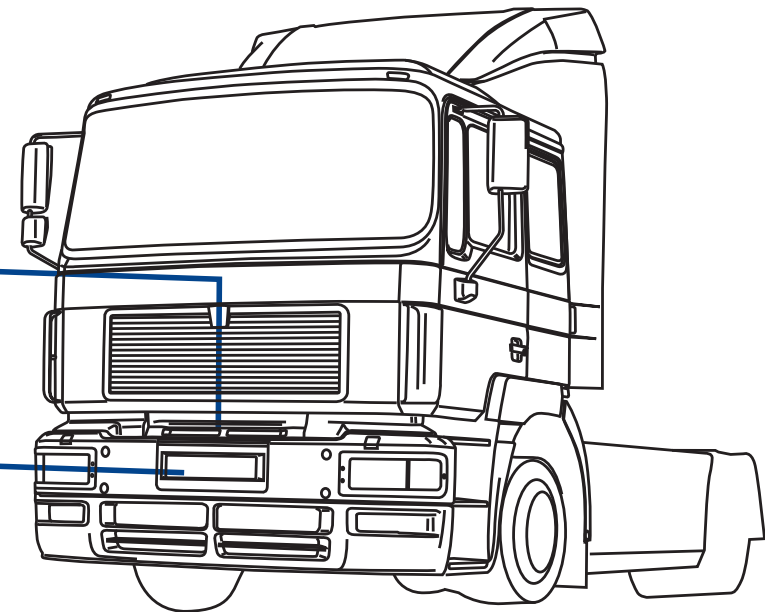

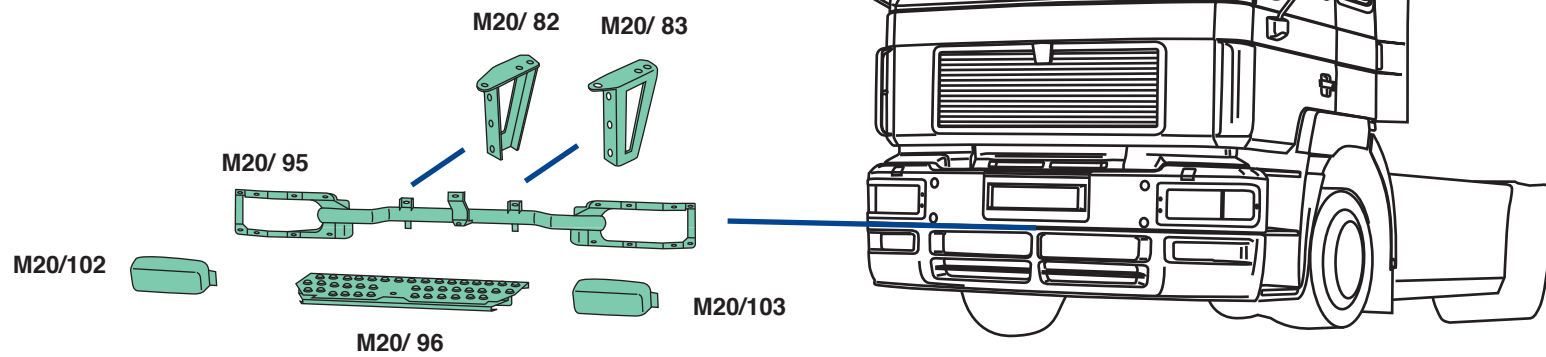

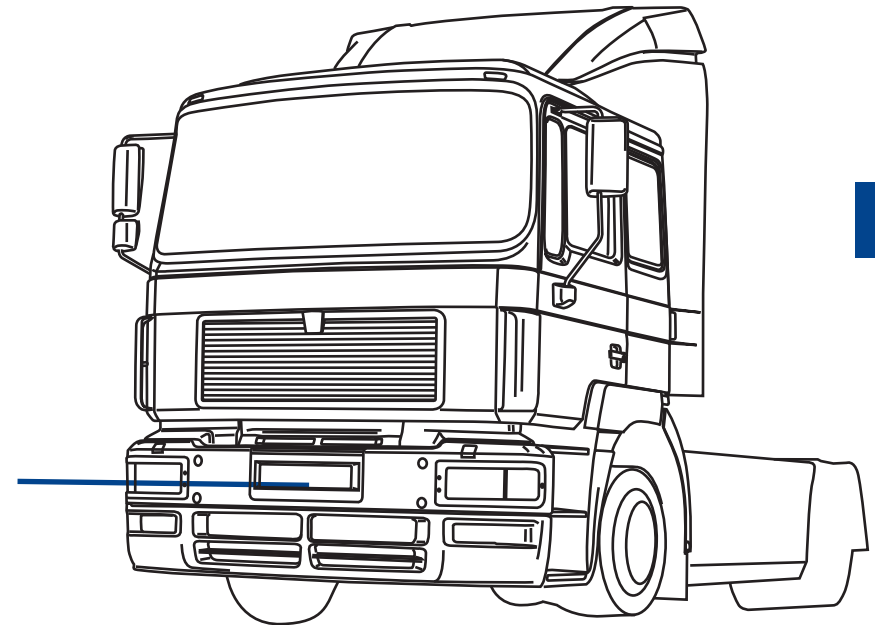
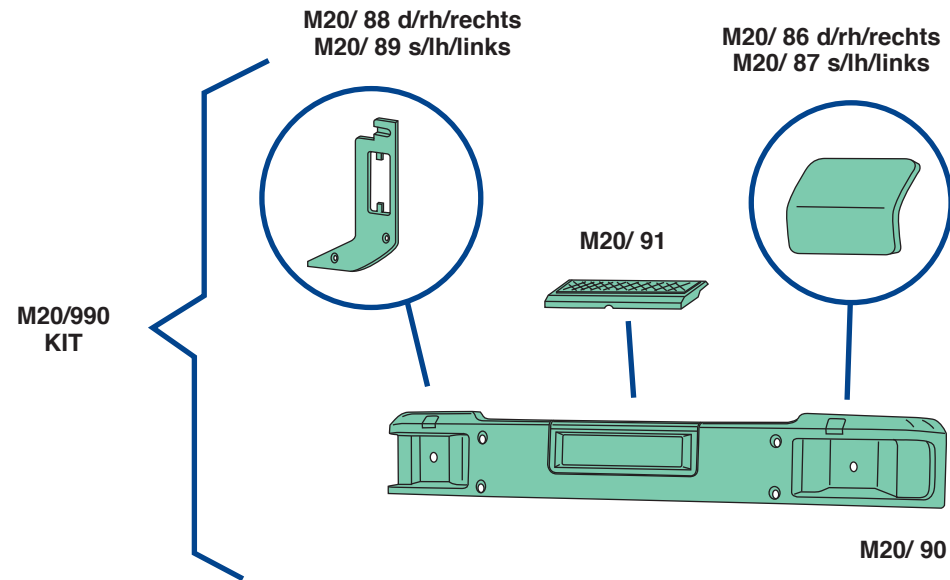

26

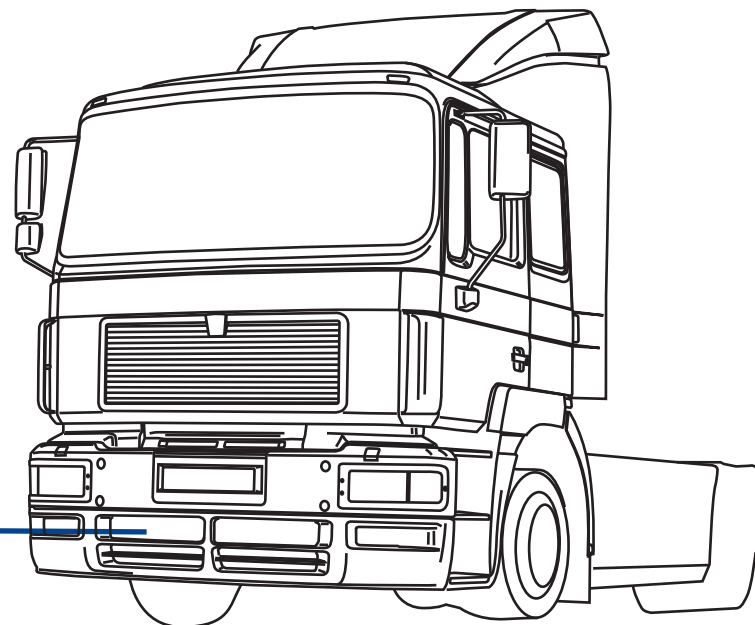

M20/992
KIT

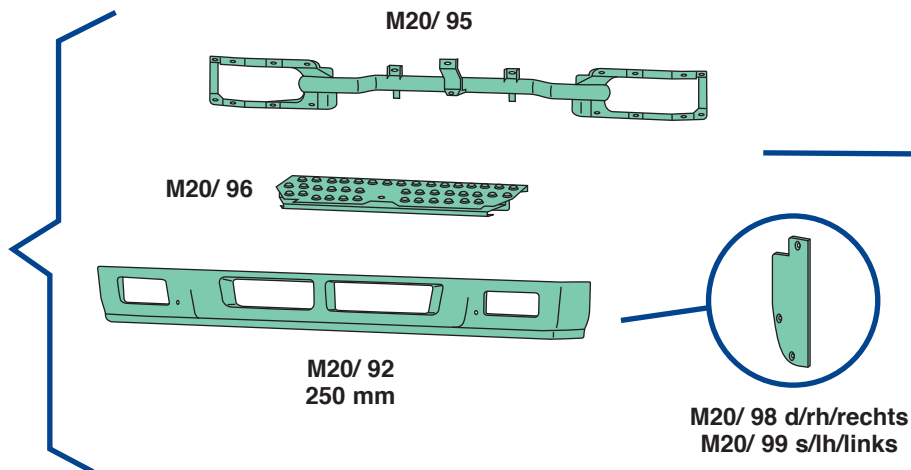

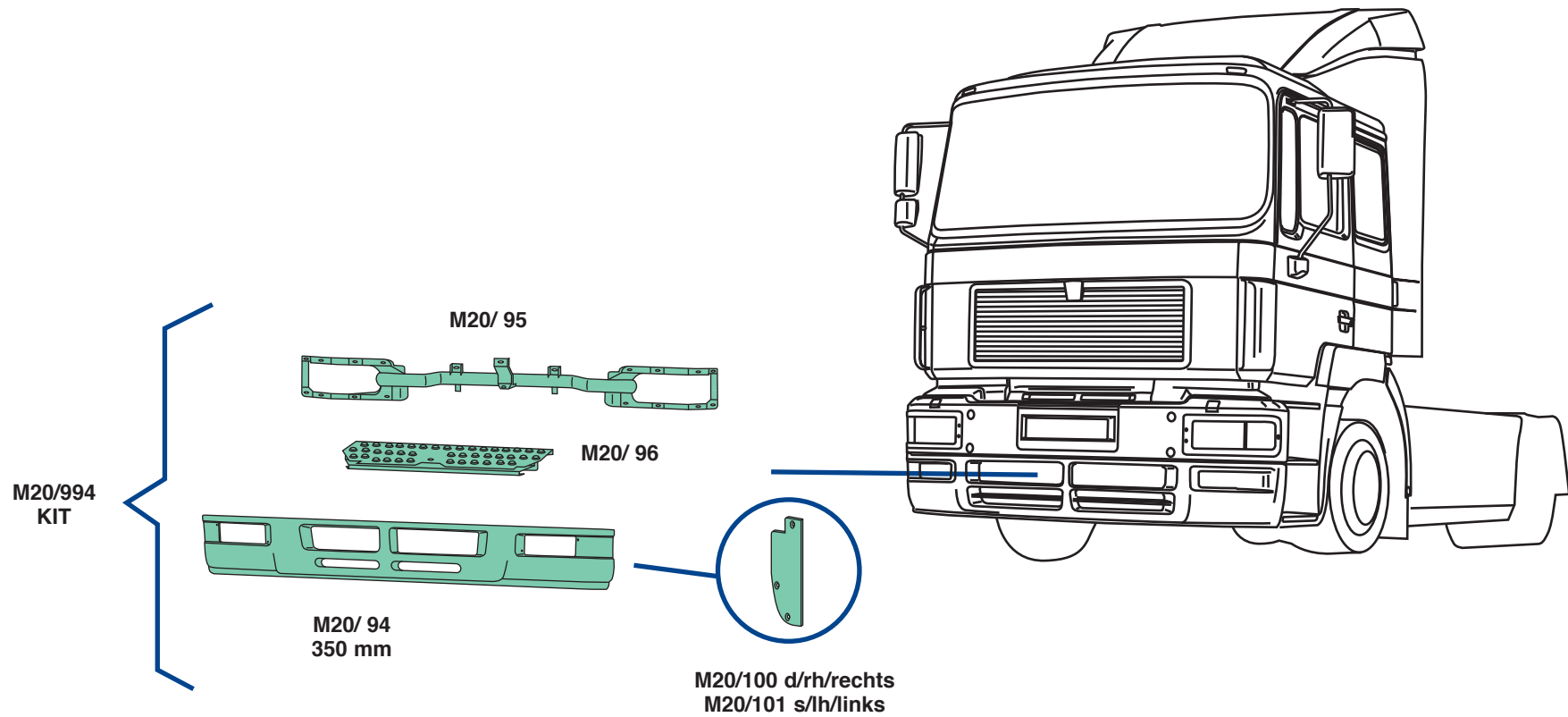

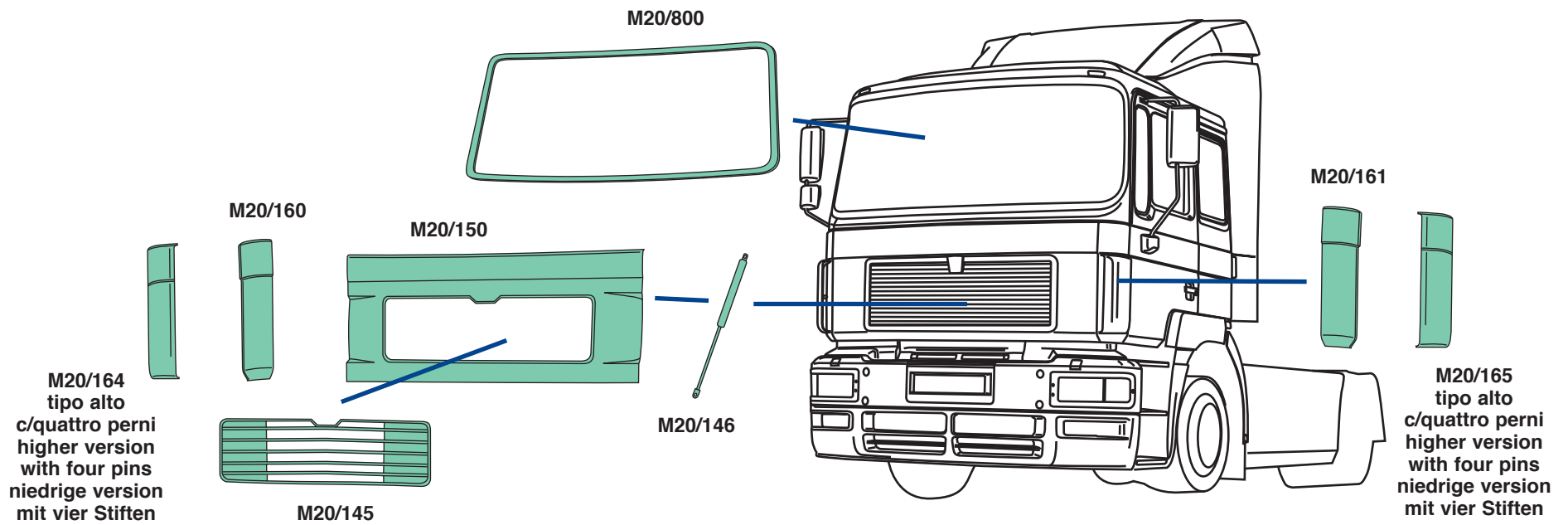

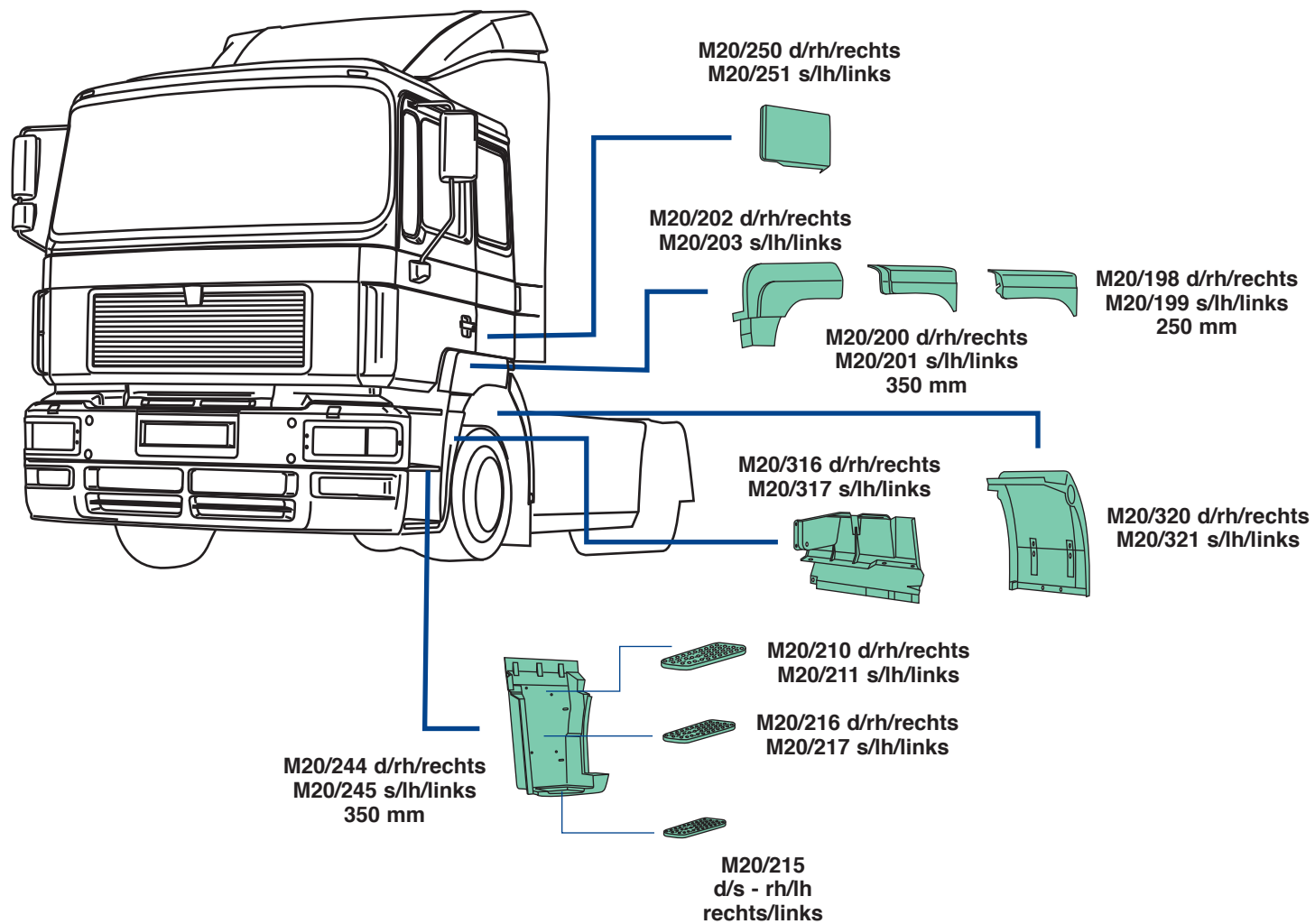

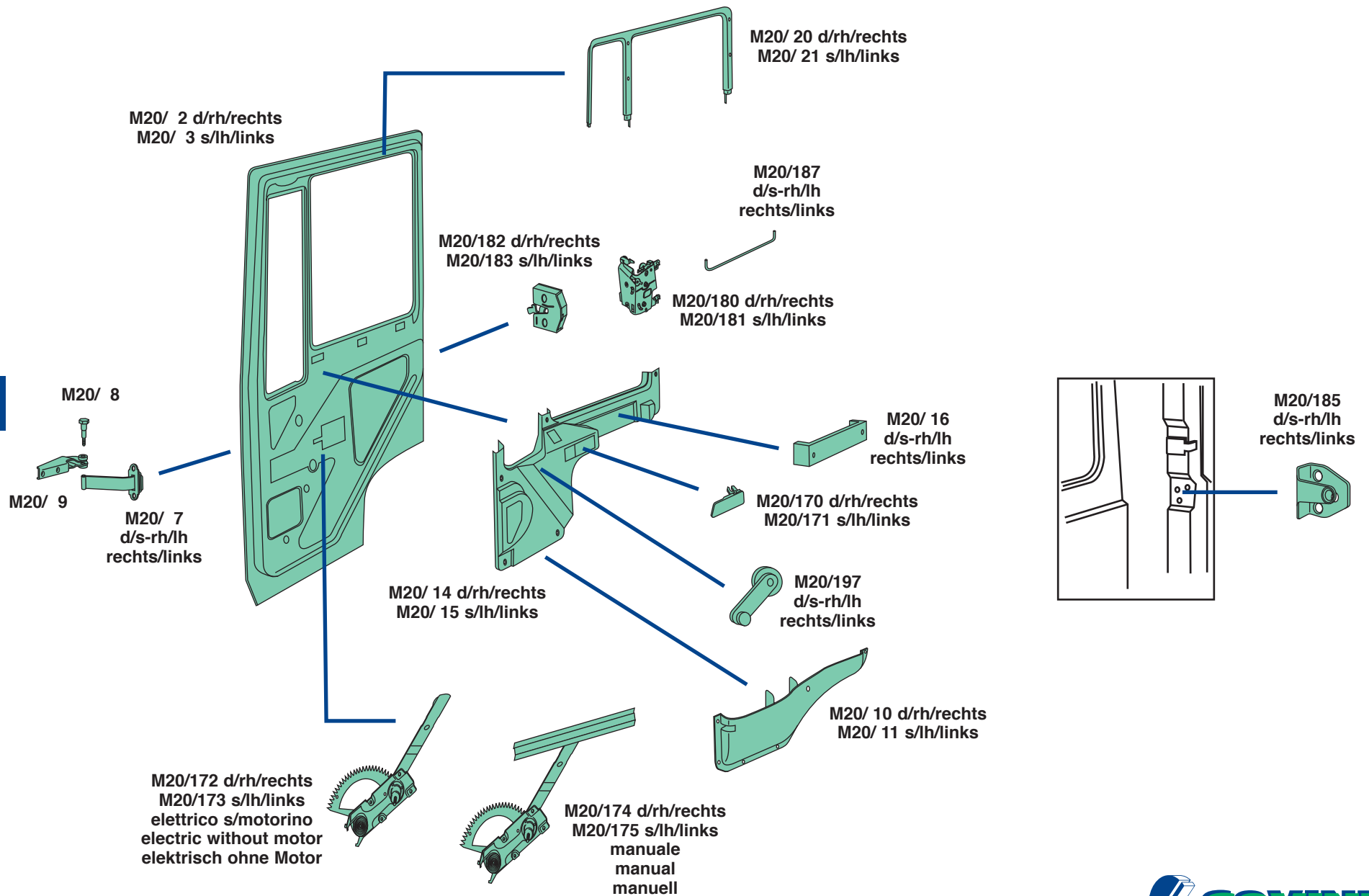

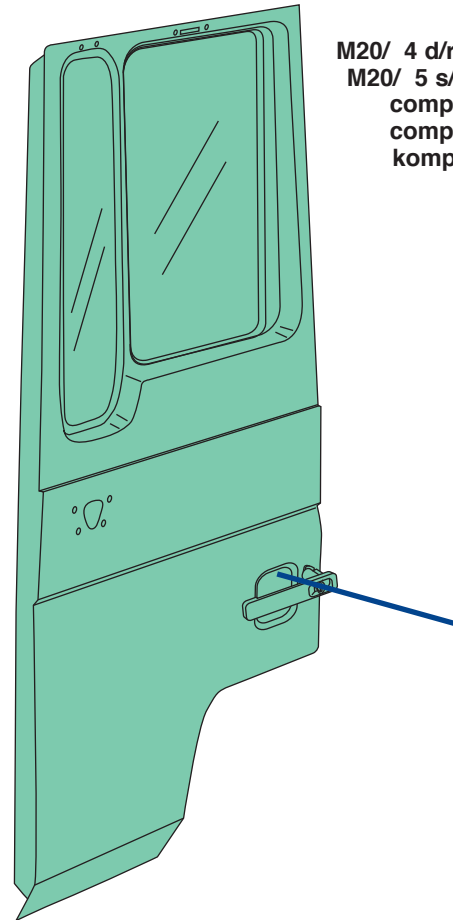

M20/ 4 d/rh/rechts
M20/ 5 s/lh/links
completa
complete
komplett

M20/194
d/s-rh/lh
rechts/links
c/chiave
with key
mit Schlüssel

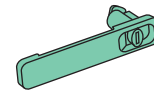
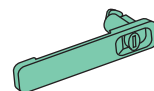
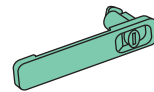

M20/196
d/s c/chiave (la coppia)
rh/lh with key (couple)
rechts/links
Satz mit Schlüssel

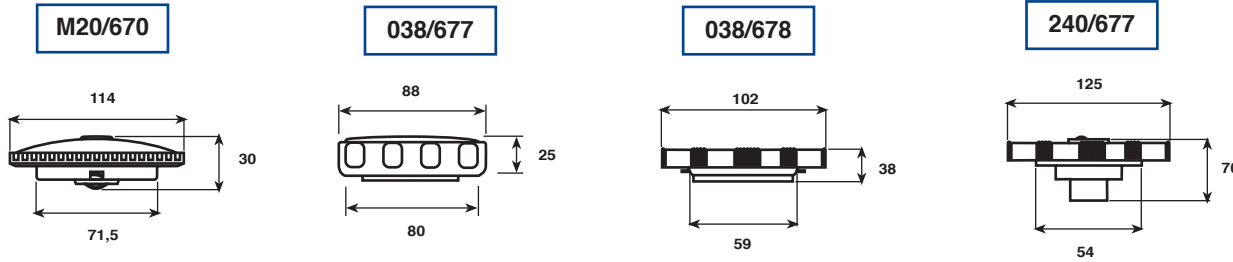

M20/670
con chiave
with key
mit Schlüssel

240/677
con chiave
with key
mit Schlüssel

038/677
sostituito da
replaced by
ersetzt durch
038/678

038/678
senza chiave
without key
ohne Schlüssel

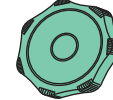

32

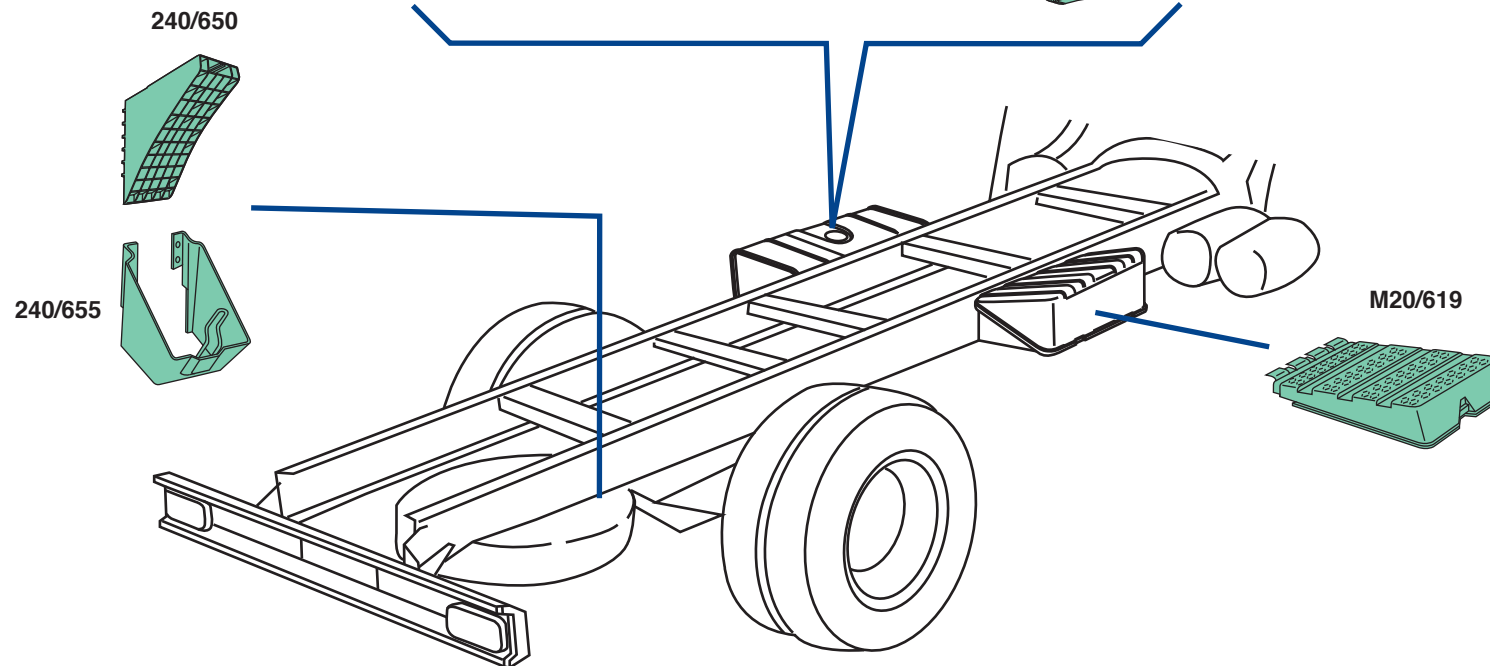





MAN

MAN F2000
CAVA/CANTIERE -YARD & QUARRY
Baustellenfahrzeug



35

MAN F2000
CAVA CANTIERE
YARD & QUARRY
BAUSTELLEFAHRZEUG

36

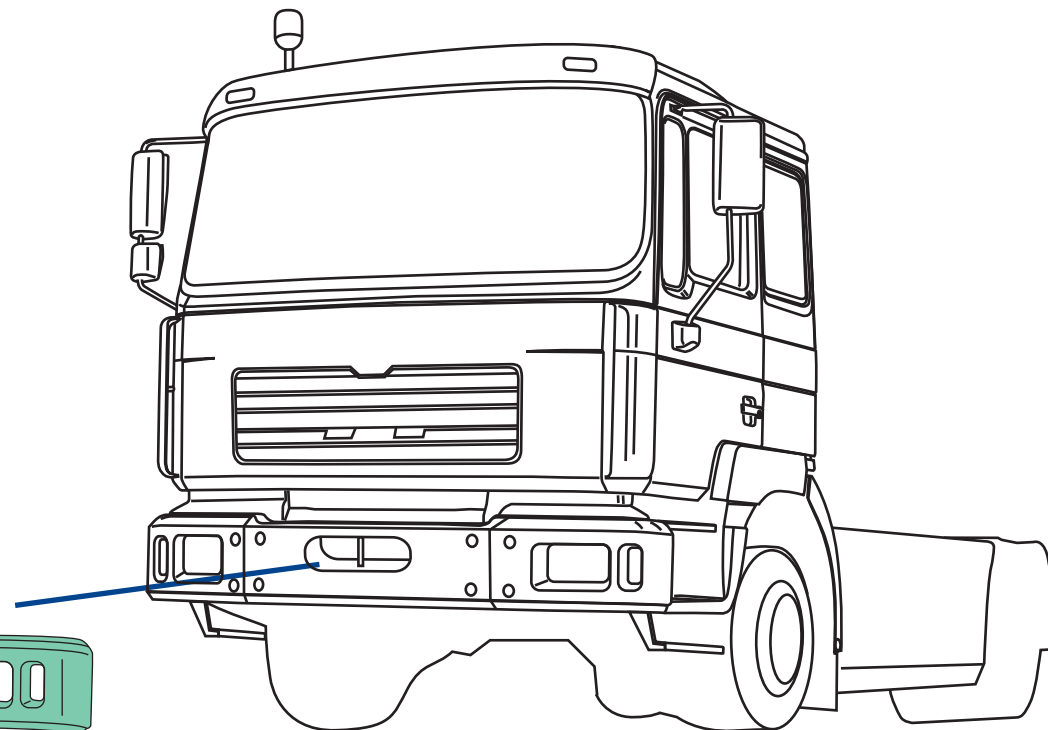
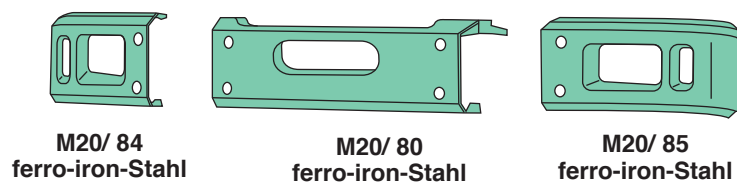

MAN F2000
CAVA CANTIERE
YARD & QUARRY
BAUSTELLEFAHRZEUG

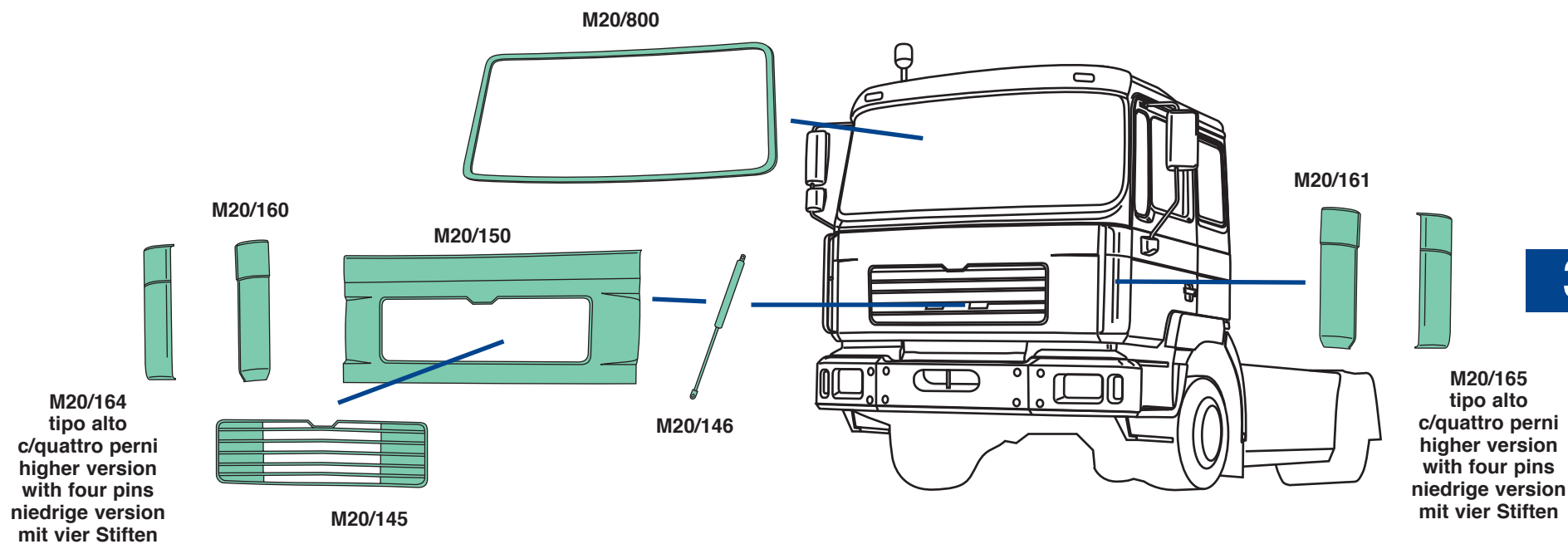

MAN F2000
CAVA CANTIERE
YARD & QUARRY
Baustellenfahrzeug

38

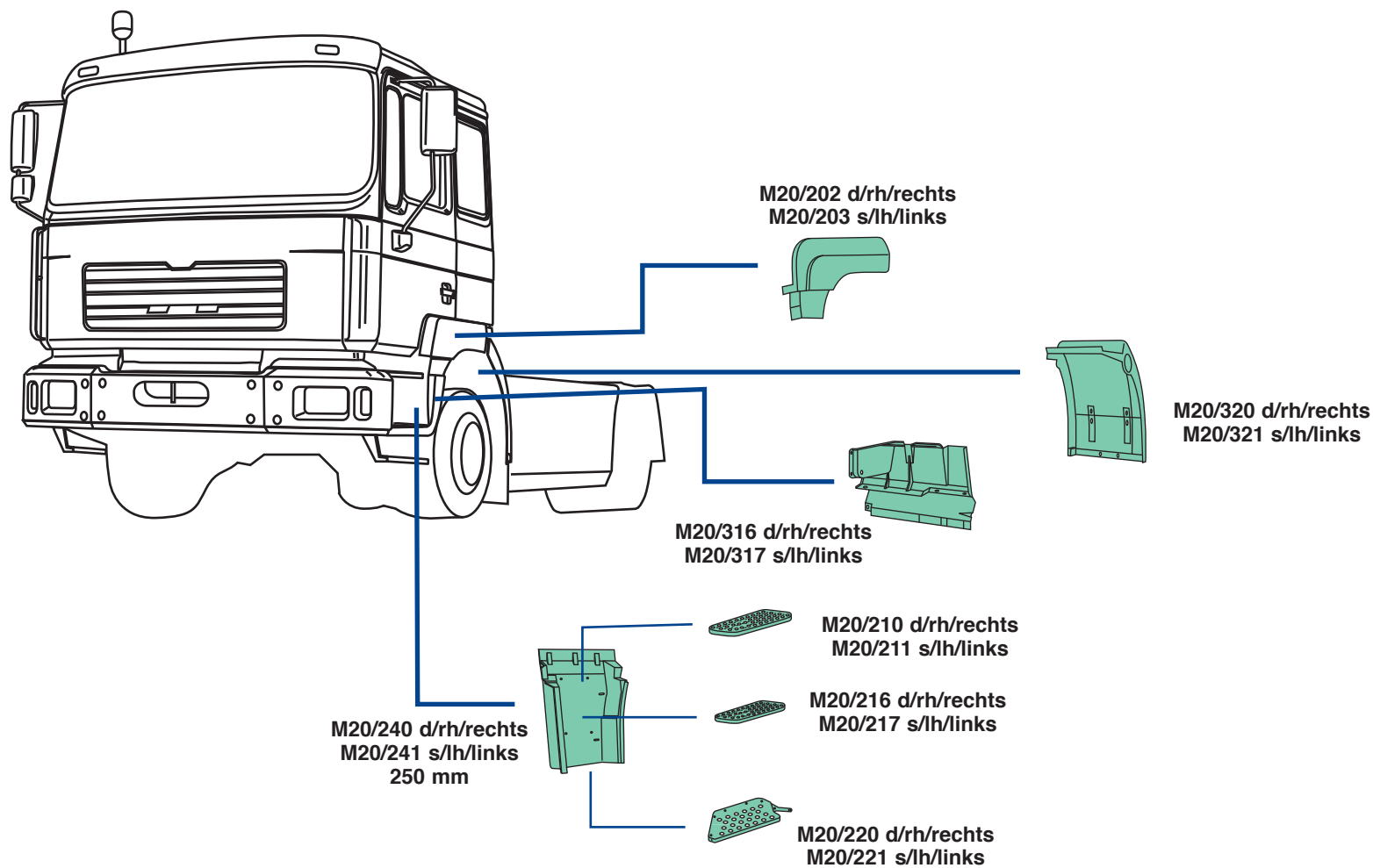

MAN F 2000
CAVA CANTIERE
YARD & QUARRY
Baustellenfahrzeug

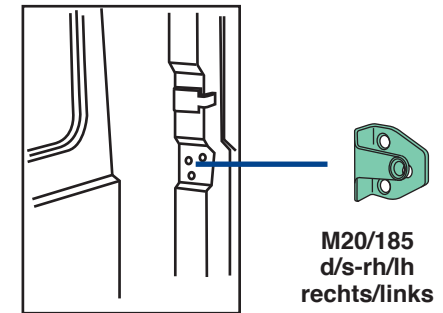
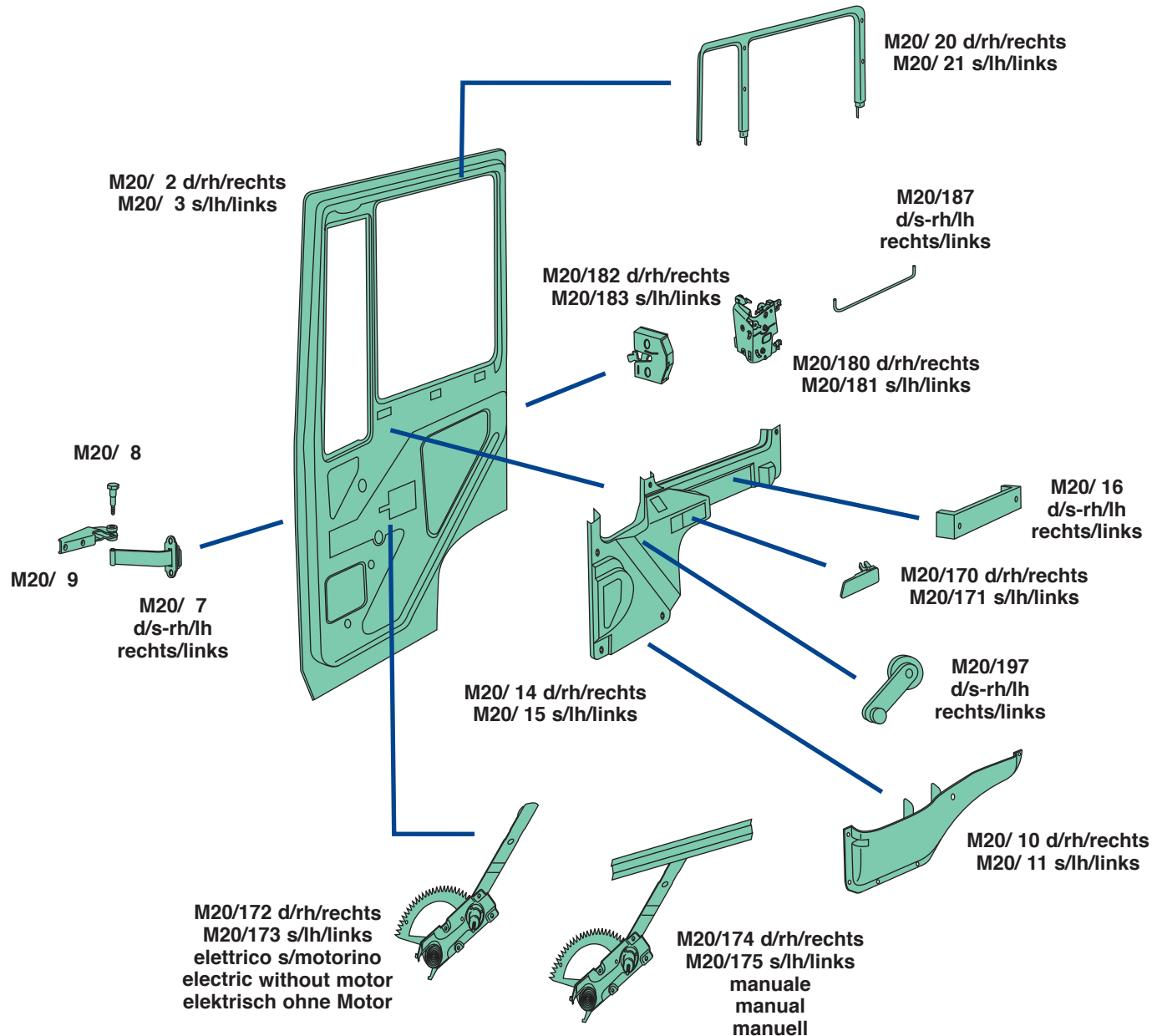

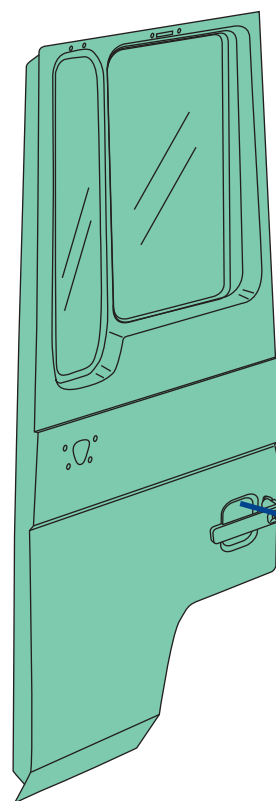

M20/ 4 d/rh/rechts
M20/ 5 s/lh/links
completa
complete
komplett

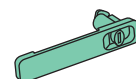

M20/194
d/s-rh/lh
rechts/links
c/chiave
with key
mit Schlüssel

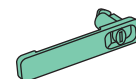
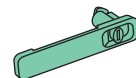

M20/196
d/s c/chiave (la coppia)
rh/lh with key (couple)
rechts/links
Satz mit Schlüssel

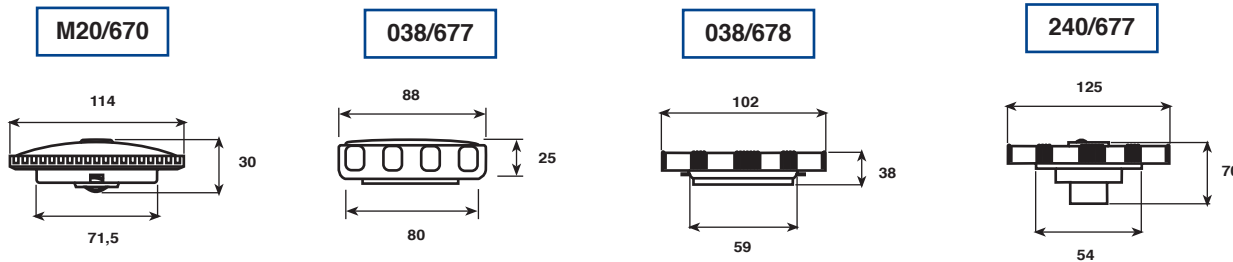

M20/670
 con chiave
 with key
 mit Schlüssel

240/677
 con chiave
 with key
 mit Schlüssel

038/677
 sostituito da
 replaced by
 ersetzt durch
038/678

038/678
 senza chiave
 without key
 ohne Schlüssel



240/650

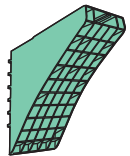

240/655

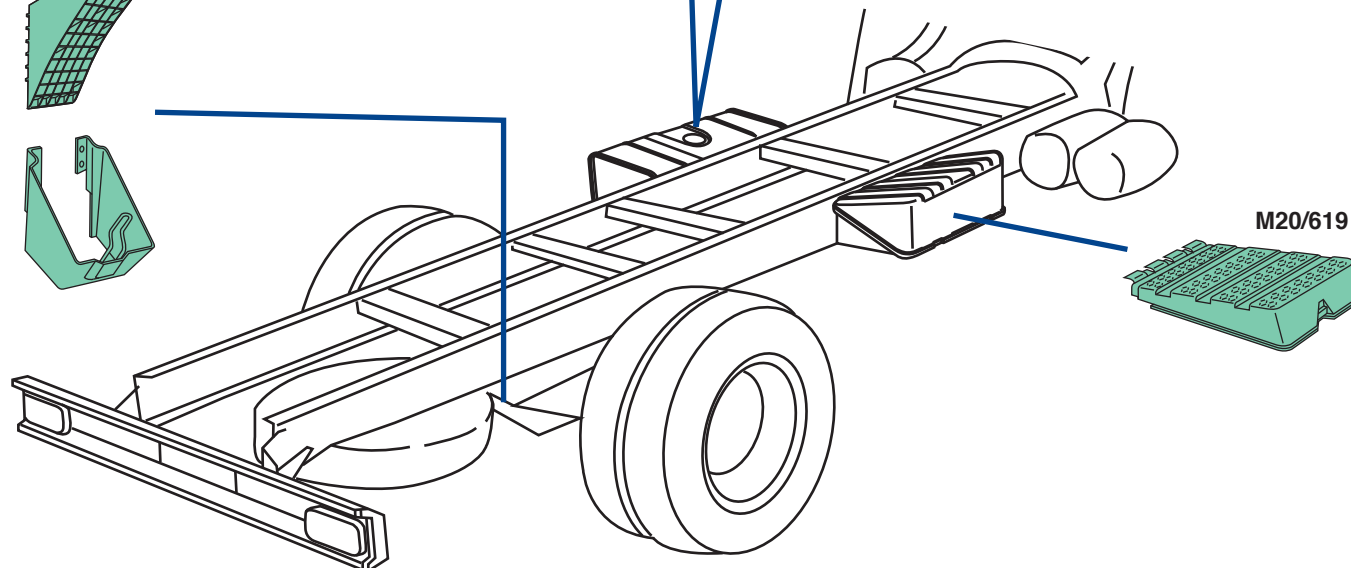
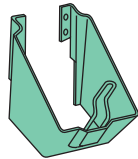

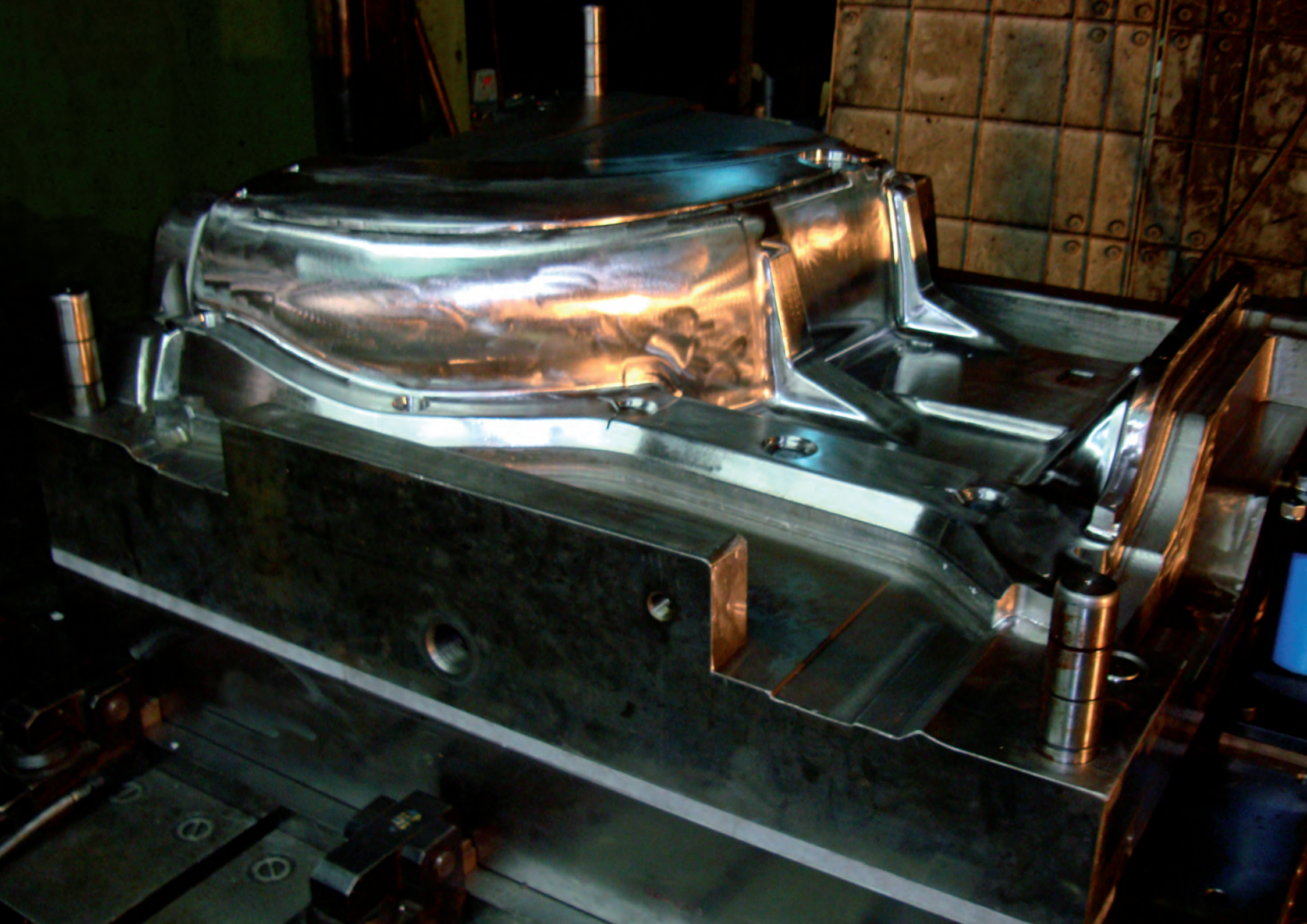

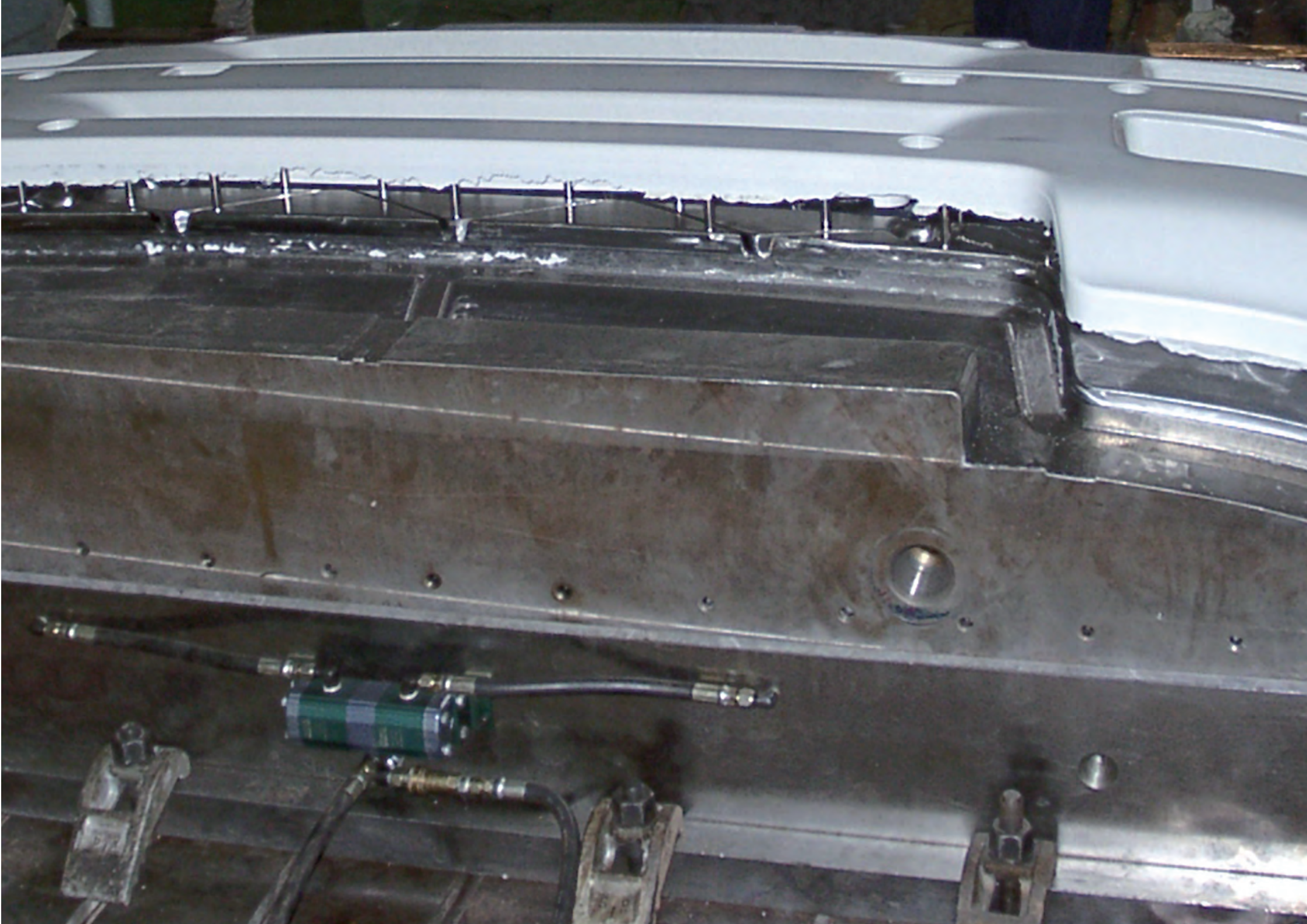



MAN

MAN TGA M-L-LX



45

- (*) Vernice di fondo
- (*) Unprocessed
- (*) grundiert
- (°) Verniciato grigio
- (°) Grey painted
- (°) grau strukturlackiert

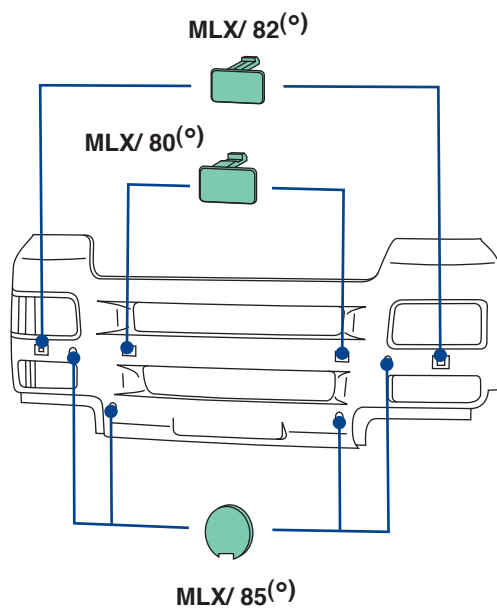

46

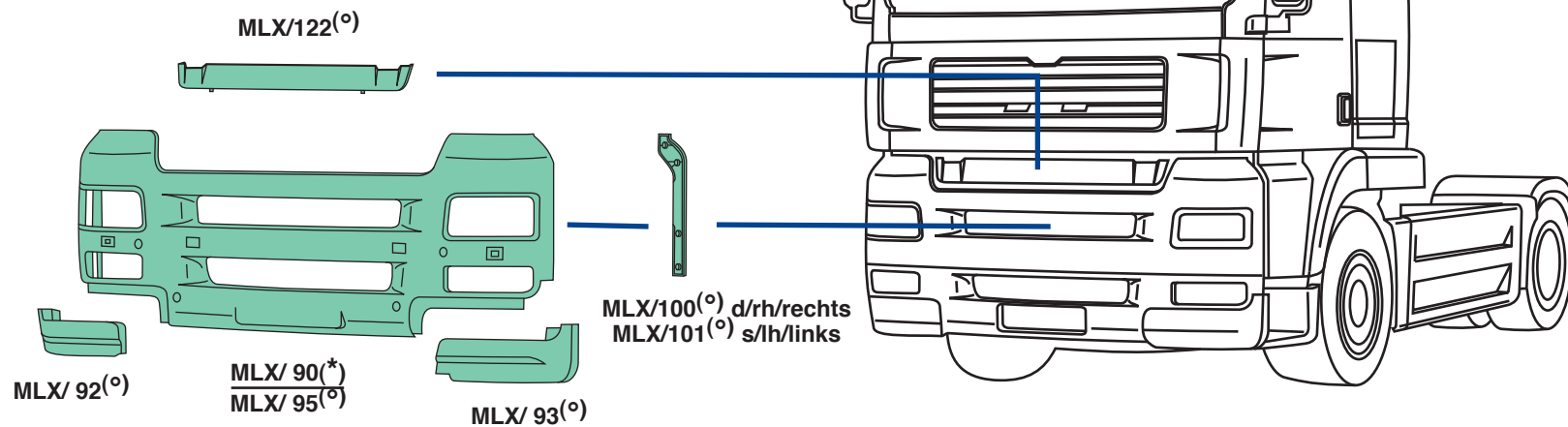

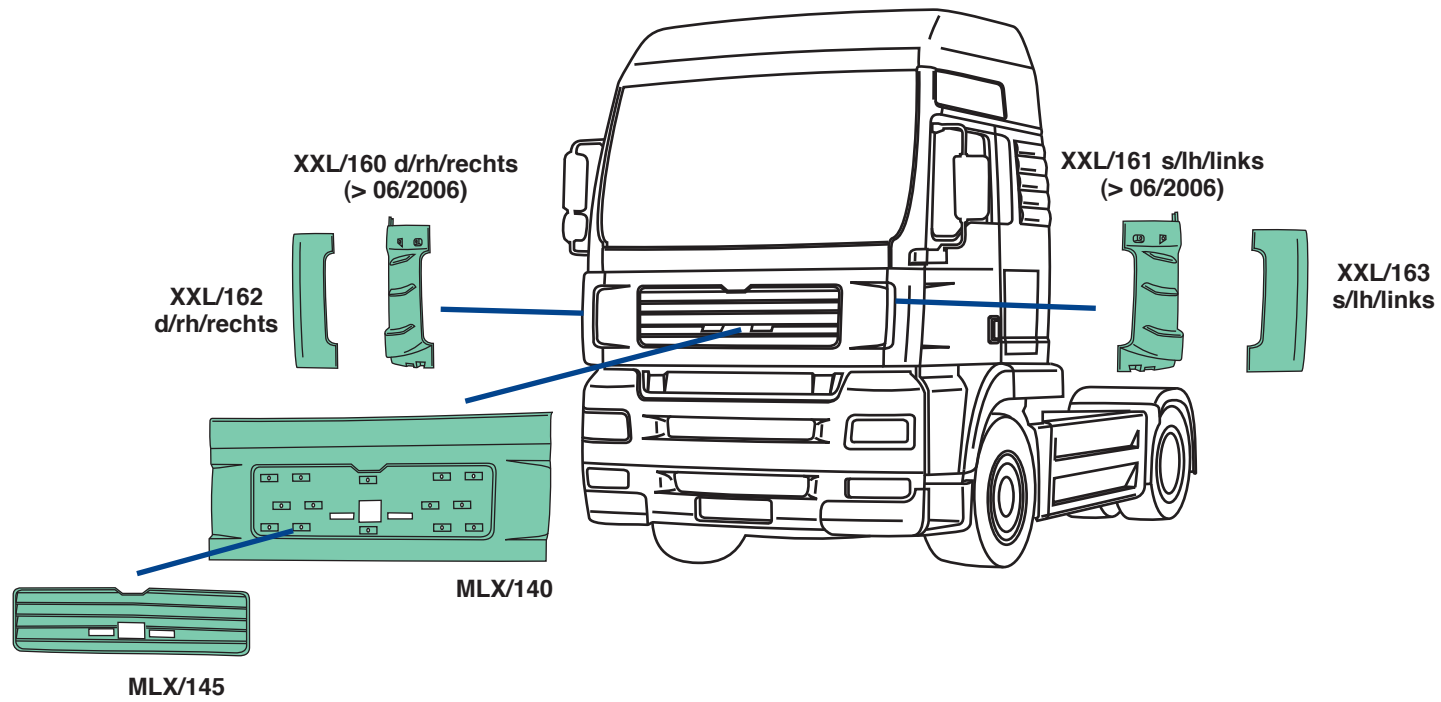

- (*) Vernice di fondo
- (*) Unprocessed
- (*) grundiert

- (°) Verniciato grigio
- (°) Grey painted
- (°) grau strukturlackiert

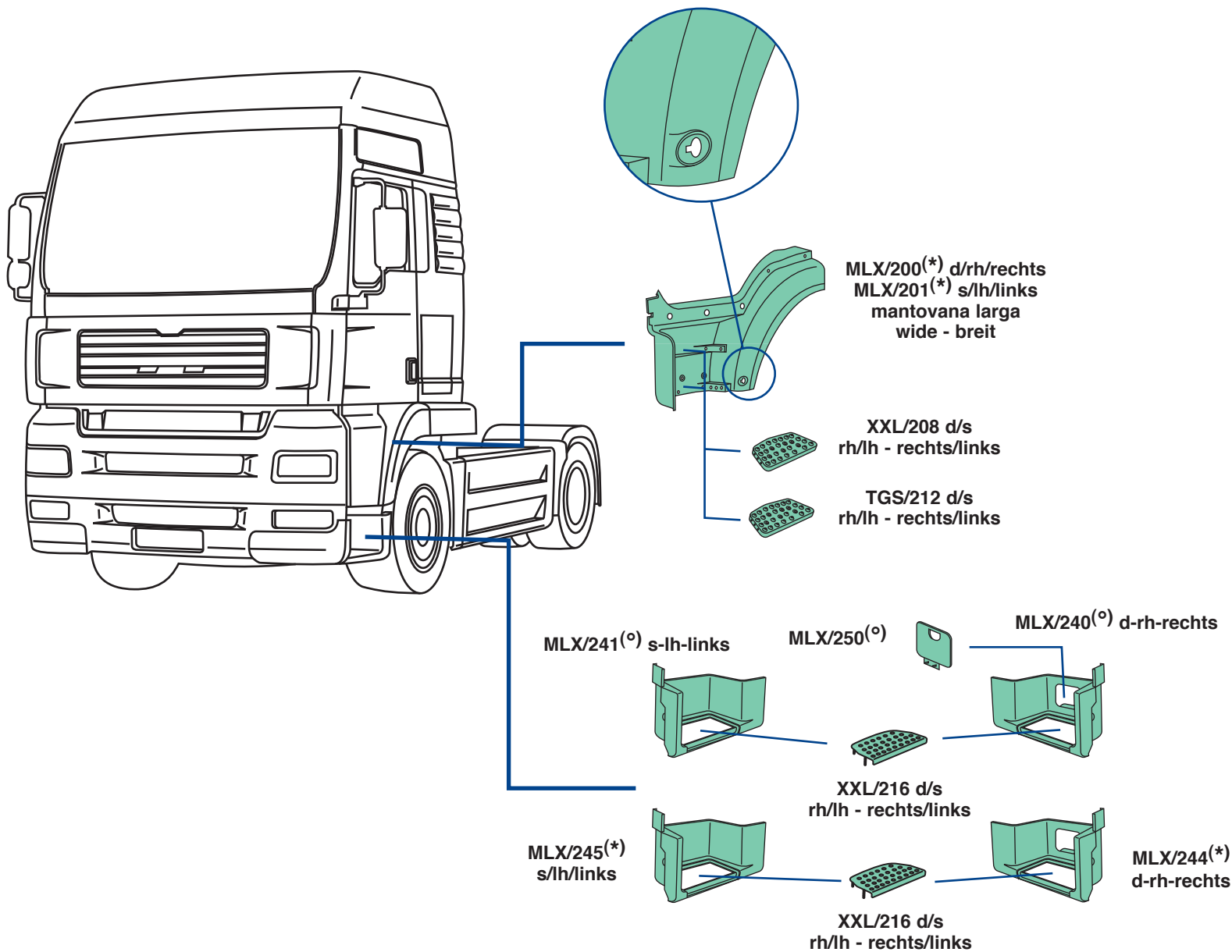

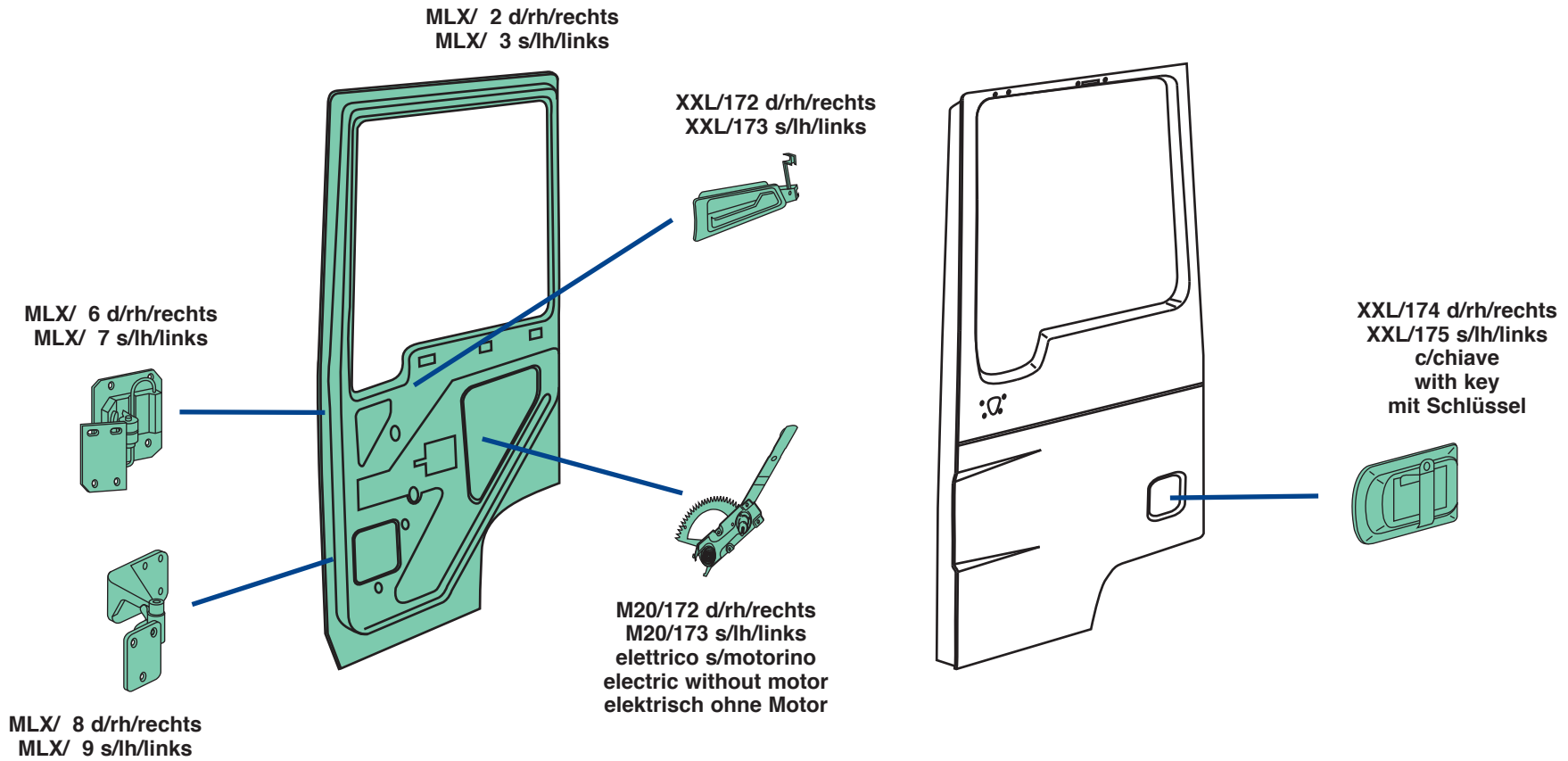

M20/670

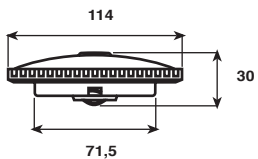

038/677

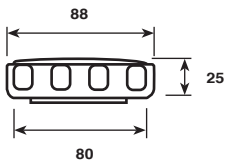

038/678

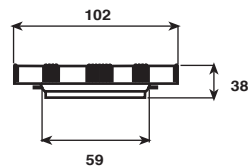

240/677

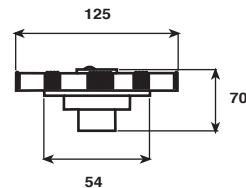

M20/670
con chiave
with key
mit Schlüssel



240/677
con chiave
with key
mit Schlüssel



038/677
sostituito da
replaced by
ersetzt durch
038/678



038/678
senza chiave
without key
ohne Schlüssel

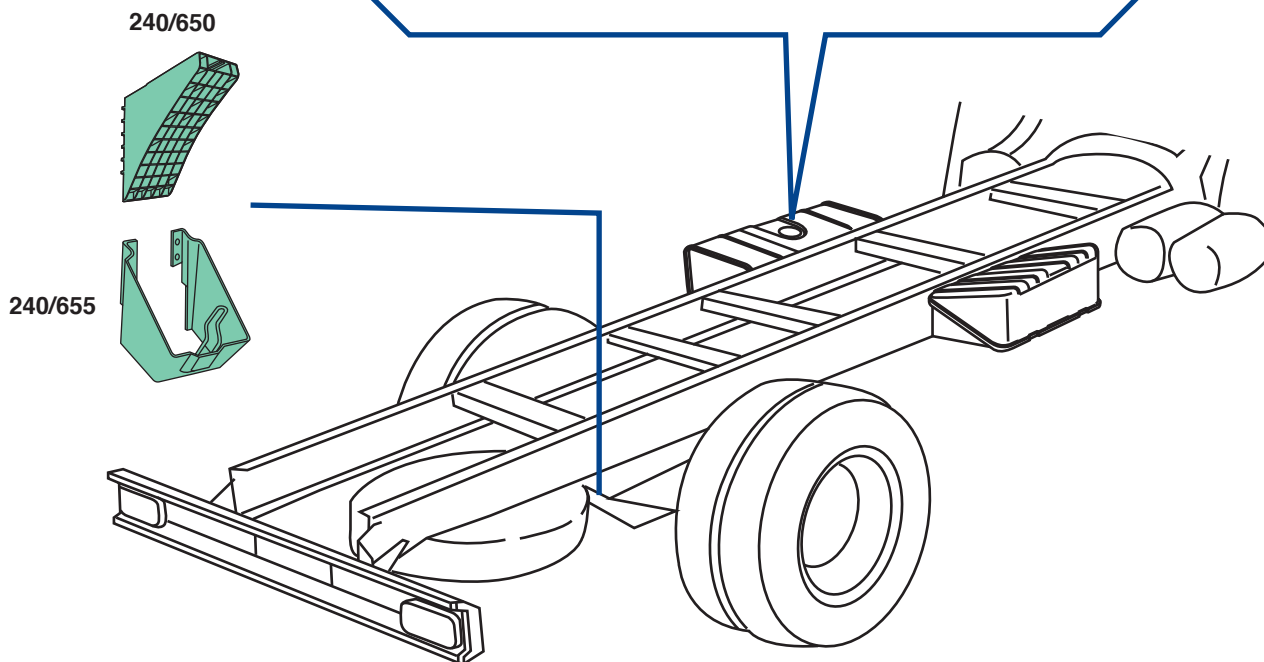
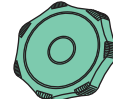



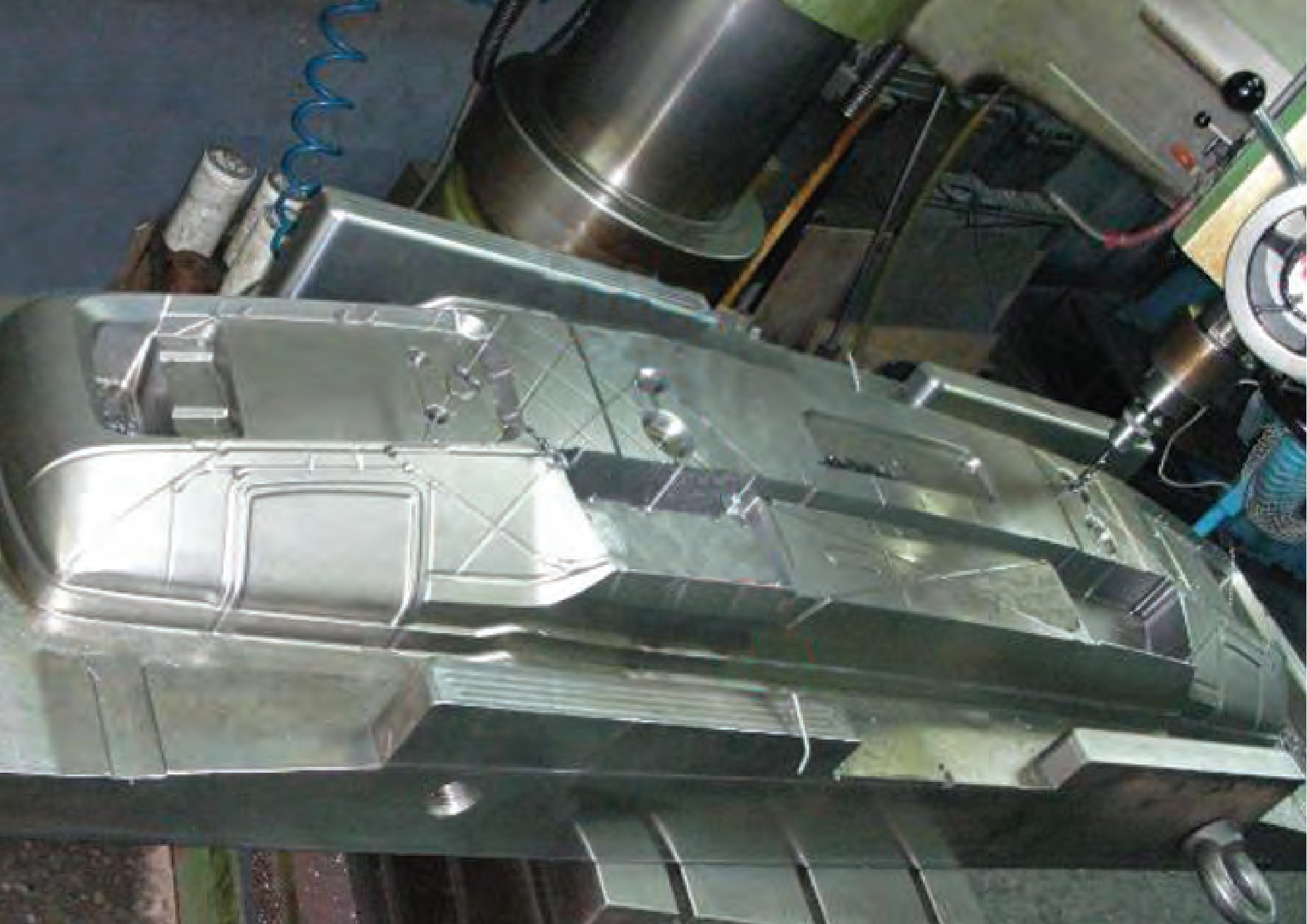

MAN

MAN TGA
CAVA/CANTIERE - YARD & QUARRY
Baustellenfahrzeug



53

- (*) Vernice di fondo
- (*) Unprocessed
- (*) grundiert

54

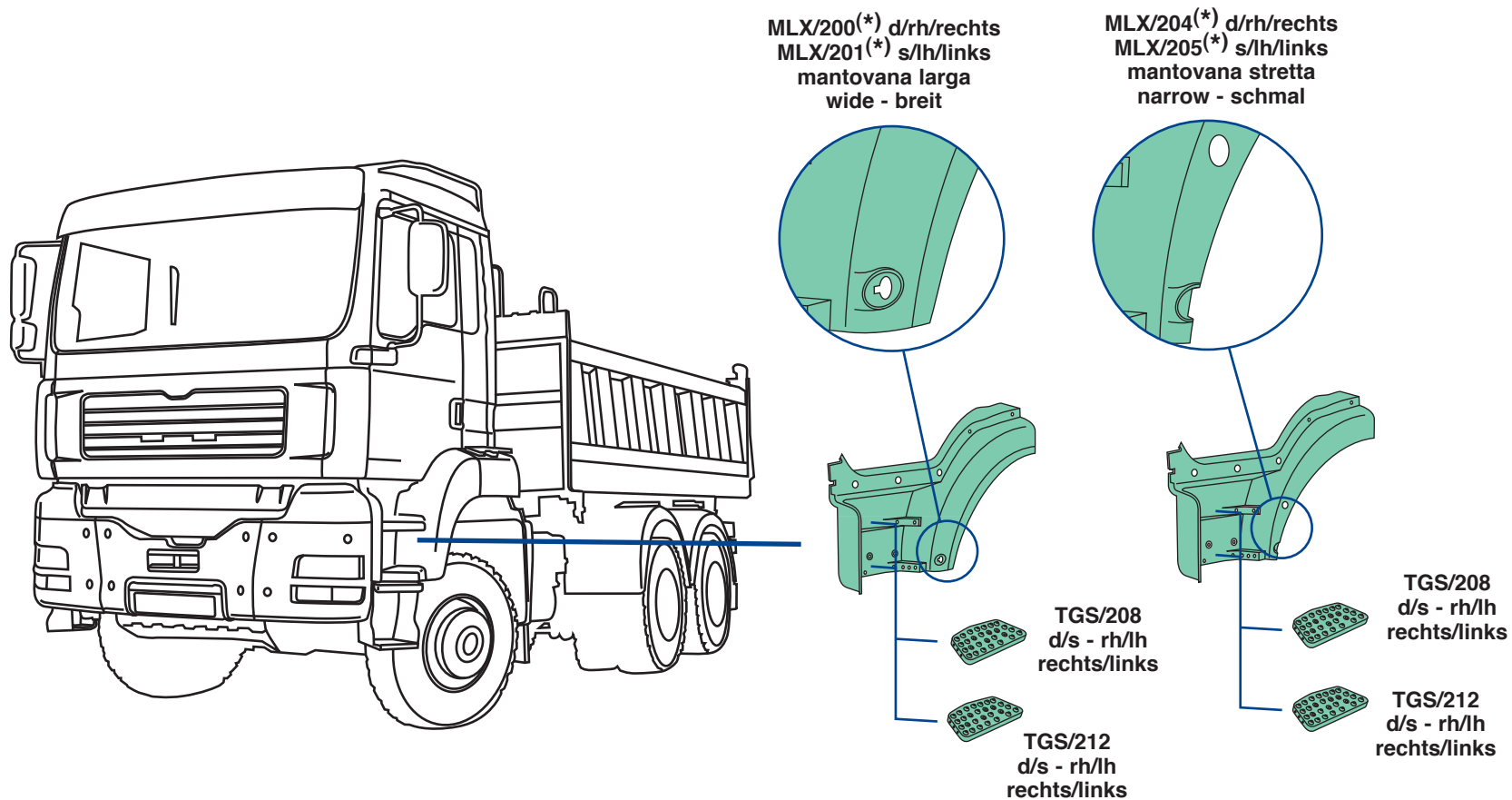

MAN

MAN TGA XLX-XXL



55

- (*) Vernice di fondo
- (*) Unprocessed
- (*) grundiert

- (°) Verniciato grigio
- (°) Grey painted
- (°) grau strukturlackiert

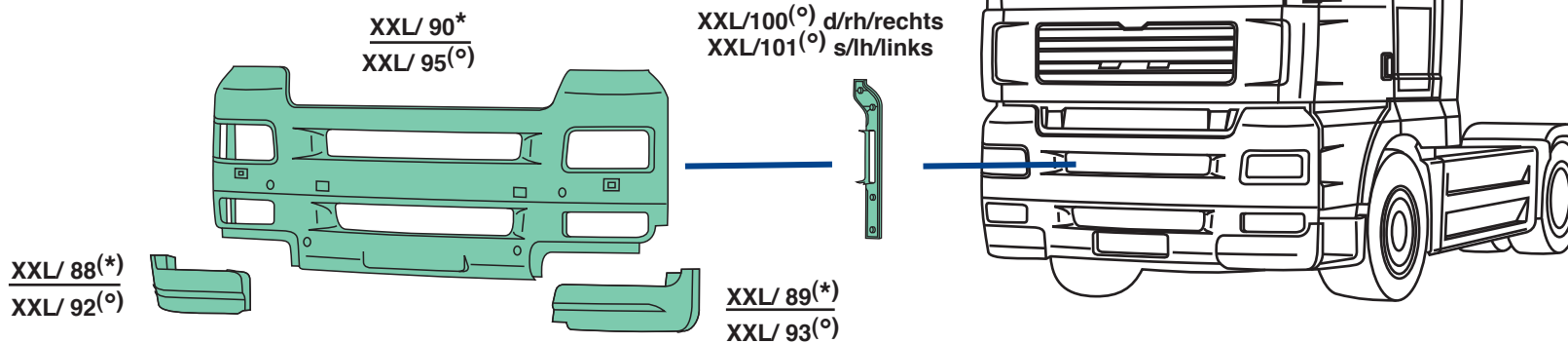
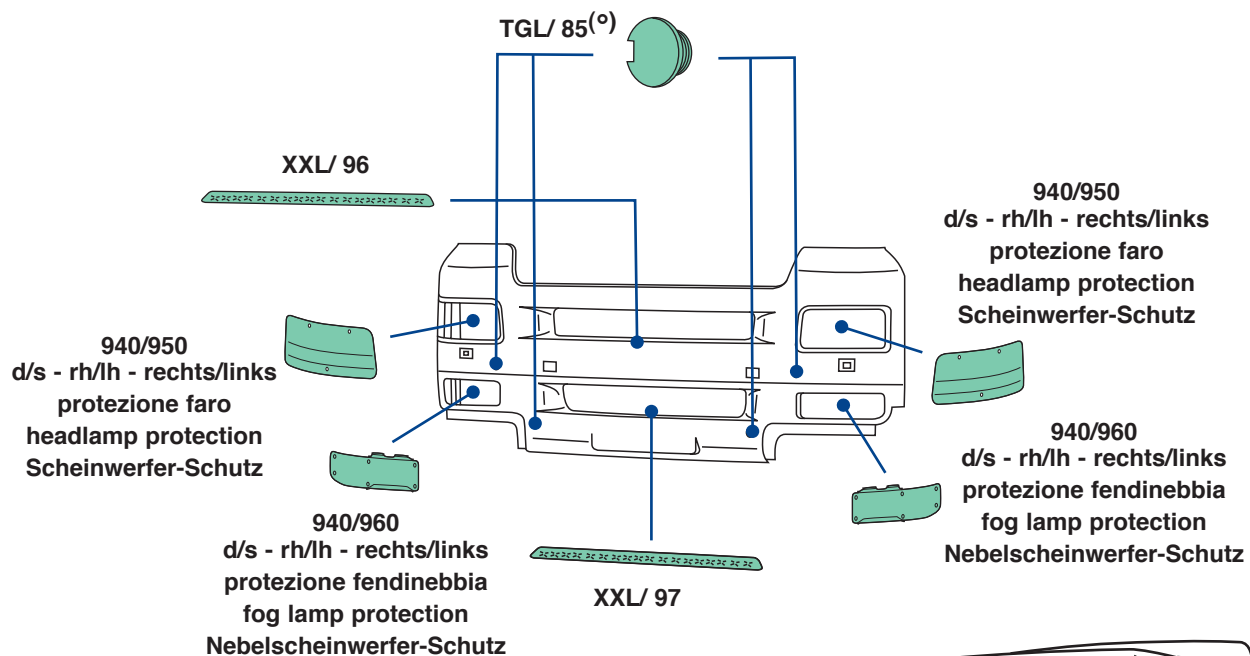

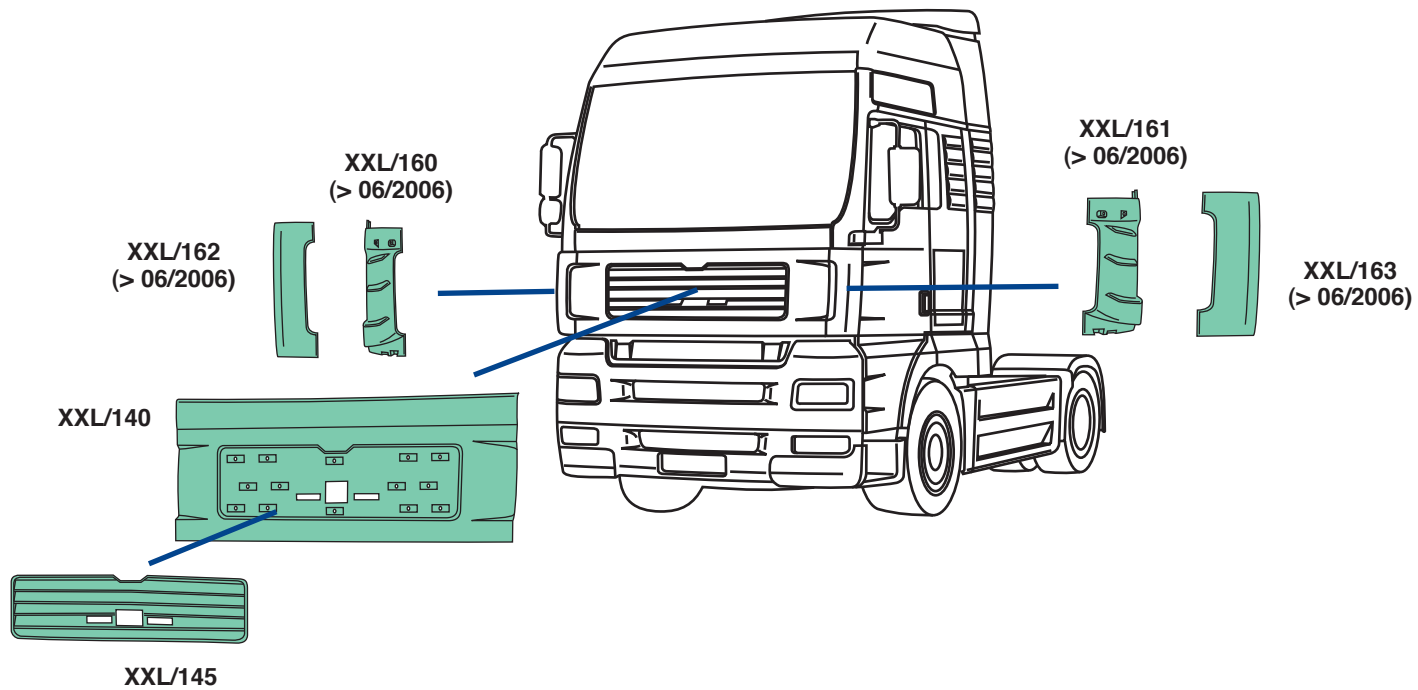

- (*) Vernice di fondo
- (*) Unprocessed
- (*) grundiert

- (°) Verniciato grigio
- (°) Grey painted
- (°) grau strukturlackiert

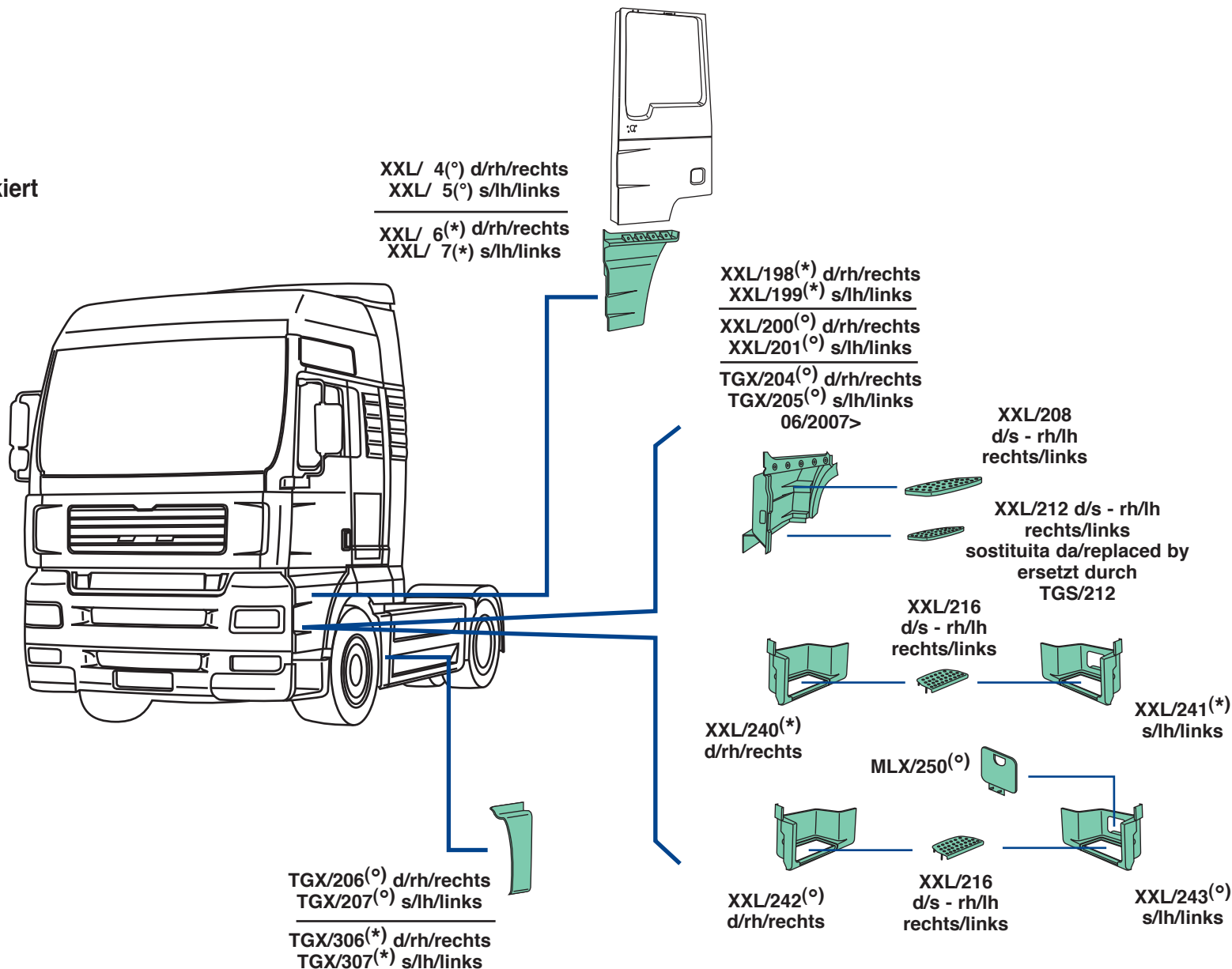

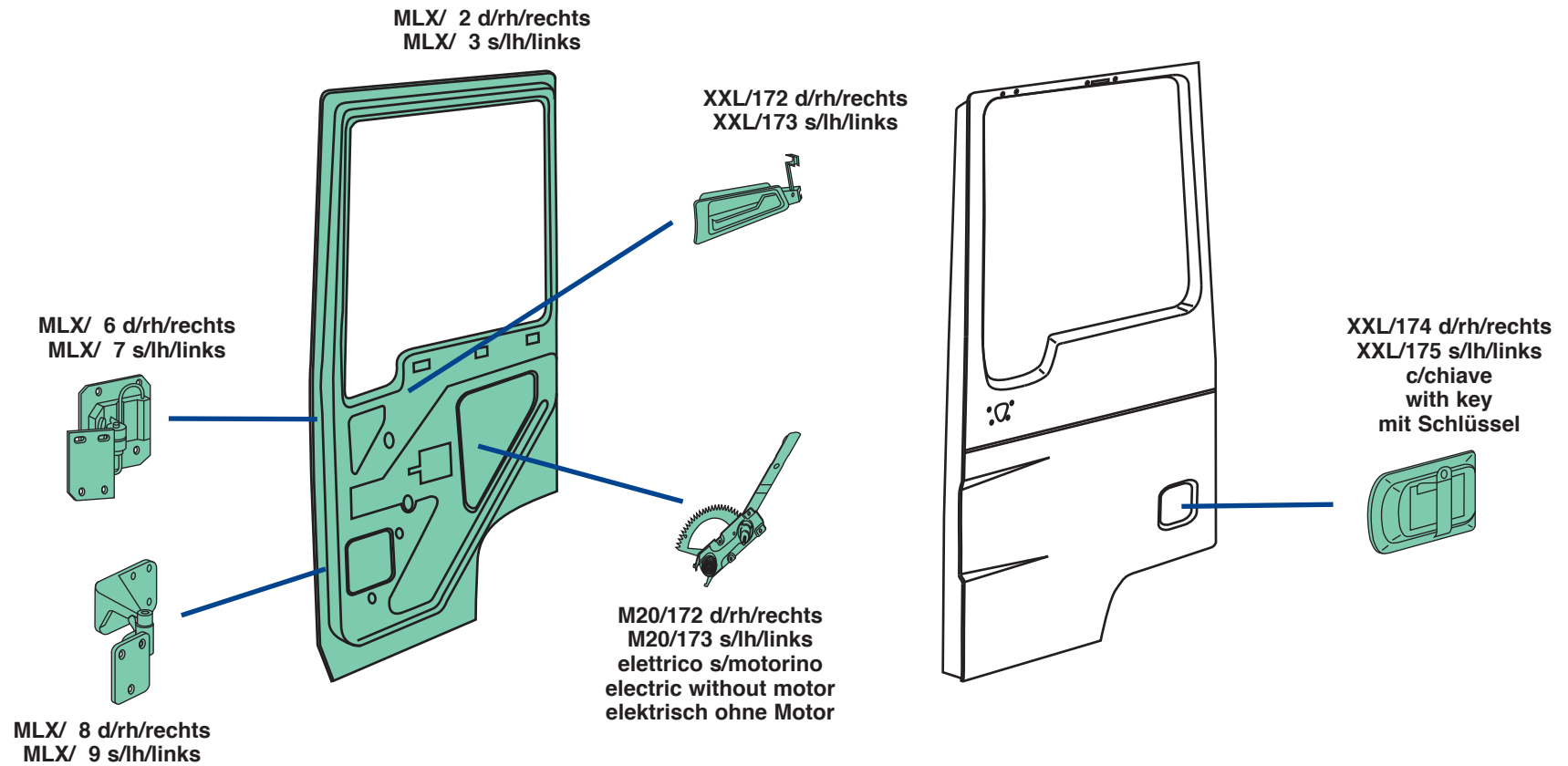

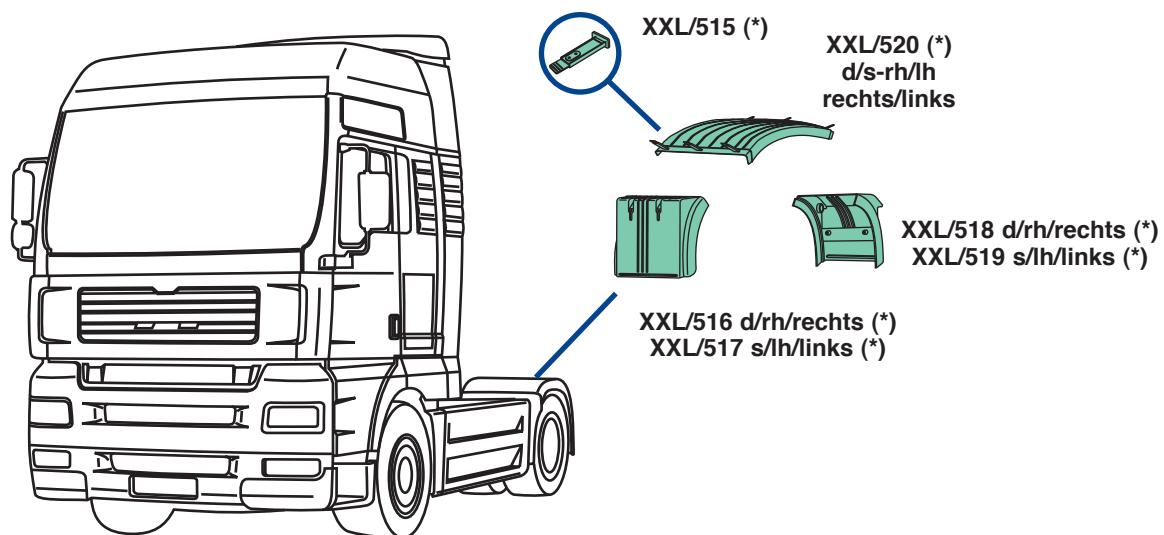

produzione fino a giugno 2006 (*)
production until june 2006 (*)
Produktion bis Juni 2006 (*)

con antispray/with antispray/mit Spritzschutz **A**

senza antispray/without antispray/ohne Spritzschutz **B**

con cinghietti/with stretchers/mit Befestigungsgummi **C**

senza cinghietti/without stretchers/ohne Befestigungsgummi **D**

60

C

XXL/520
d/s-rh/lh
rechts/links

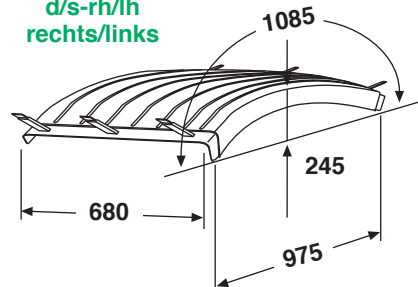

B

XXL/518 d/rh/rechts
XXL/519 s/lh/links

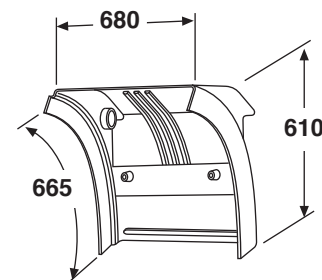

B

XXL/516 d/rh/rechts
XXL/517 s/lh/links

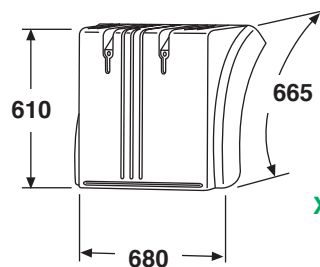

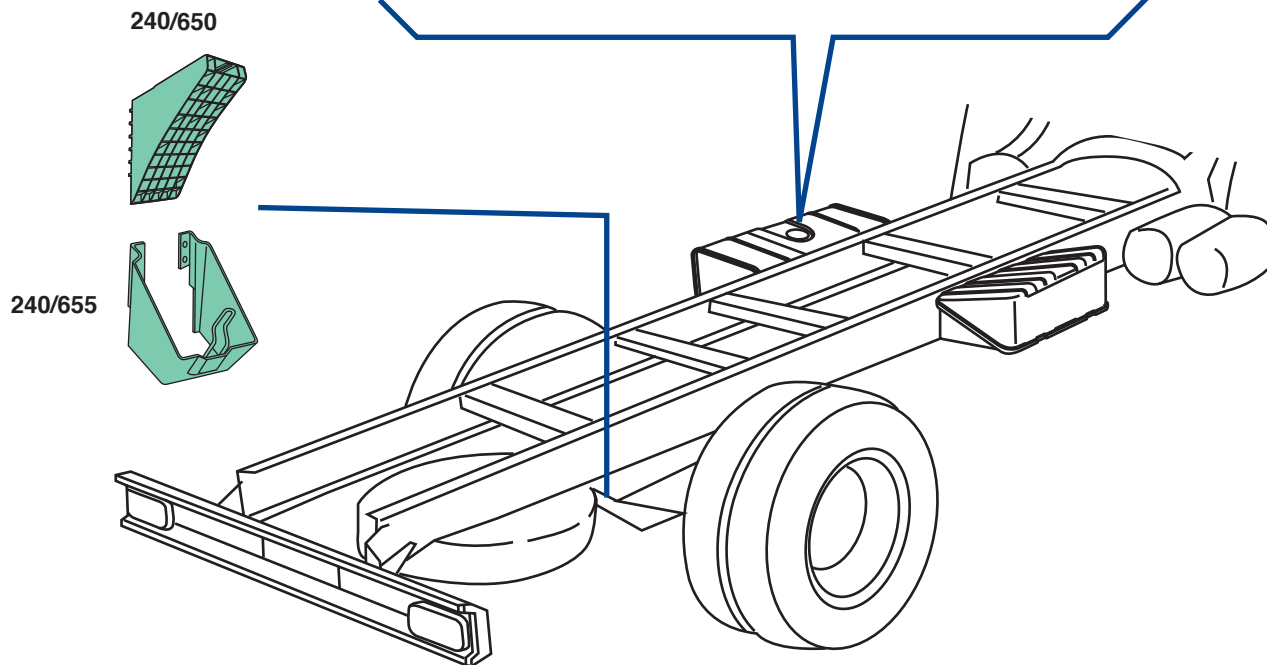
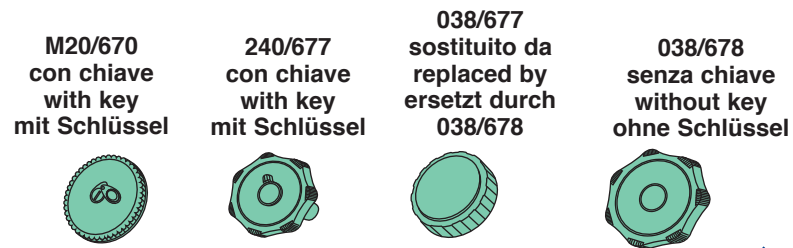
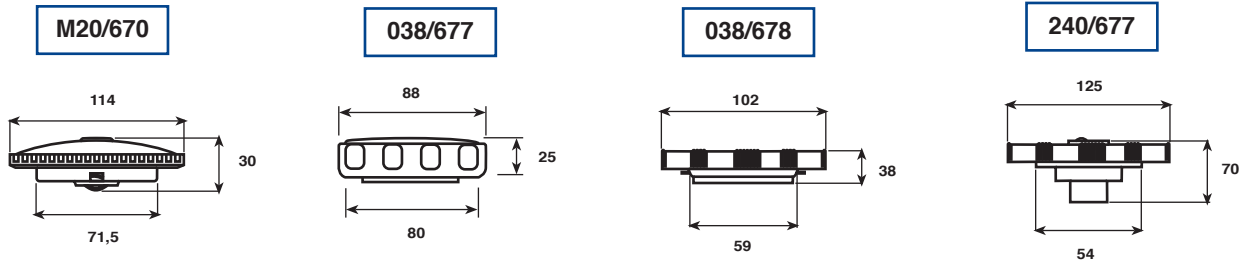



MIRCEDES
BENZ

MIRCEDES
BENZ

MIRCEDES
BENZ

MAN

MAN TGS



- (*) Vernice di fondo
- (*) Unprocessed
- (*) grundiert

- (°) Verniciato grigio
- (°) Grey painted
- (°) grau strukturlackiert

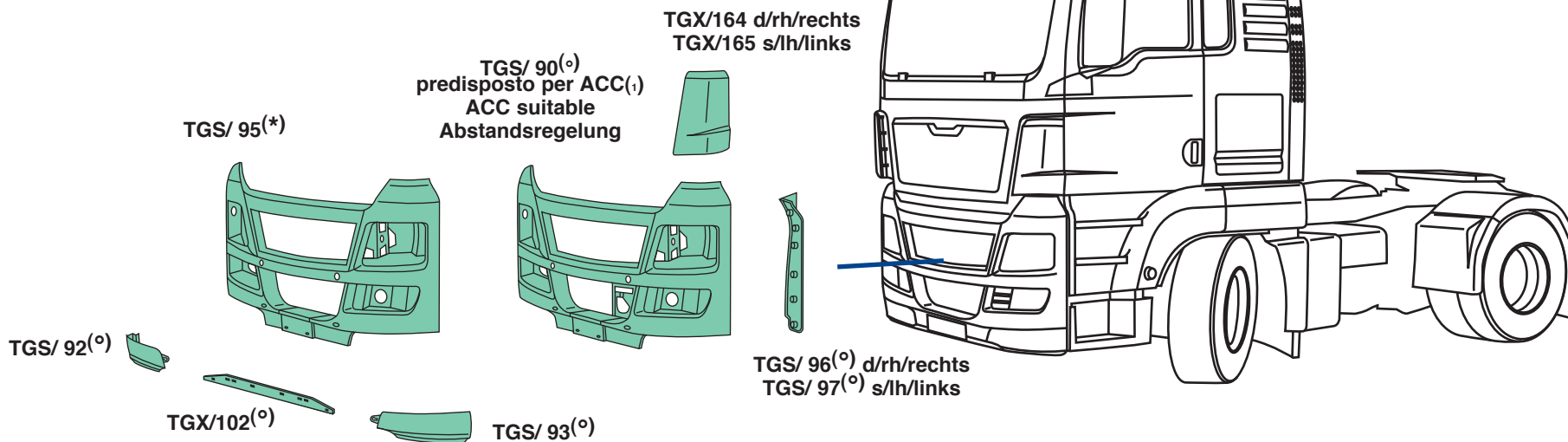
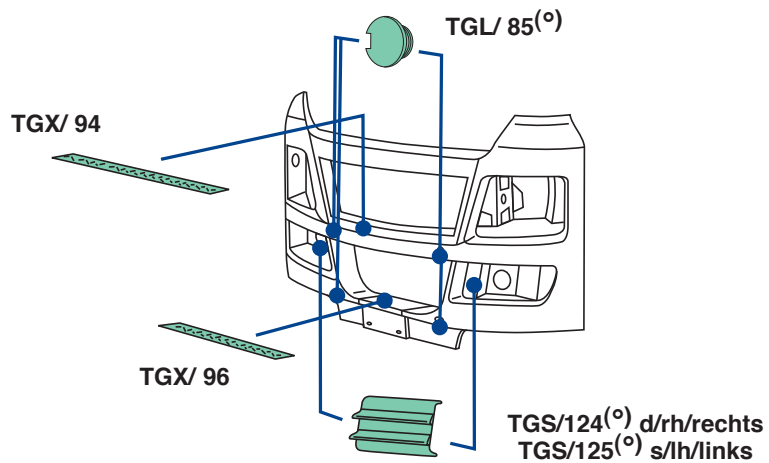

(1) Active Cruise Control - aktive Abstandsregelung

- (*) Vernice di fondo
- (*) Unprocessed
- (*) grundiert

- (°) Verniciato grigio
- (°) Grey painted
- (°) grau strukturlackiert

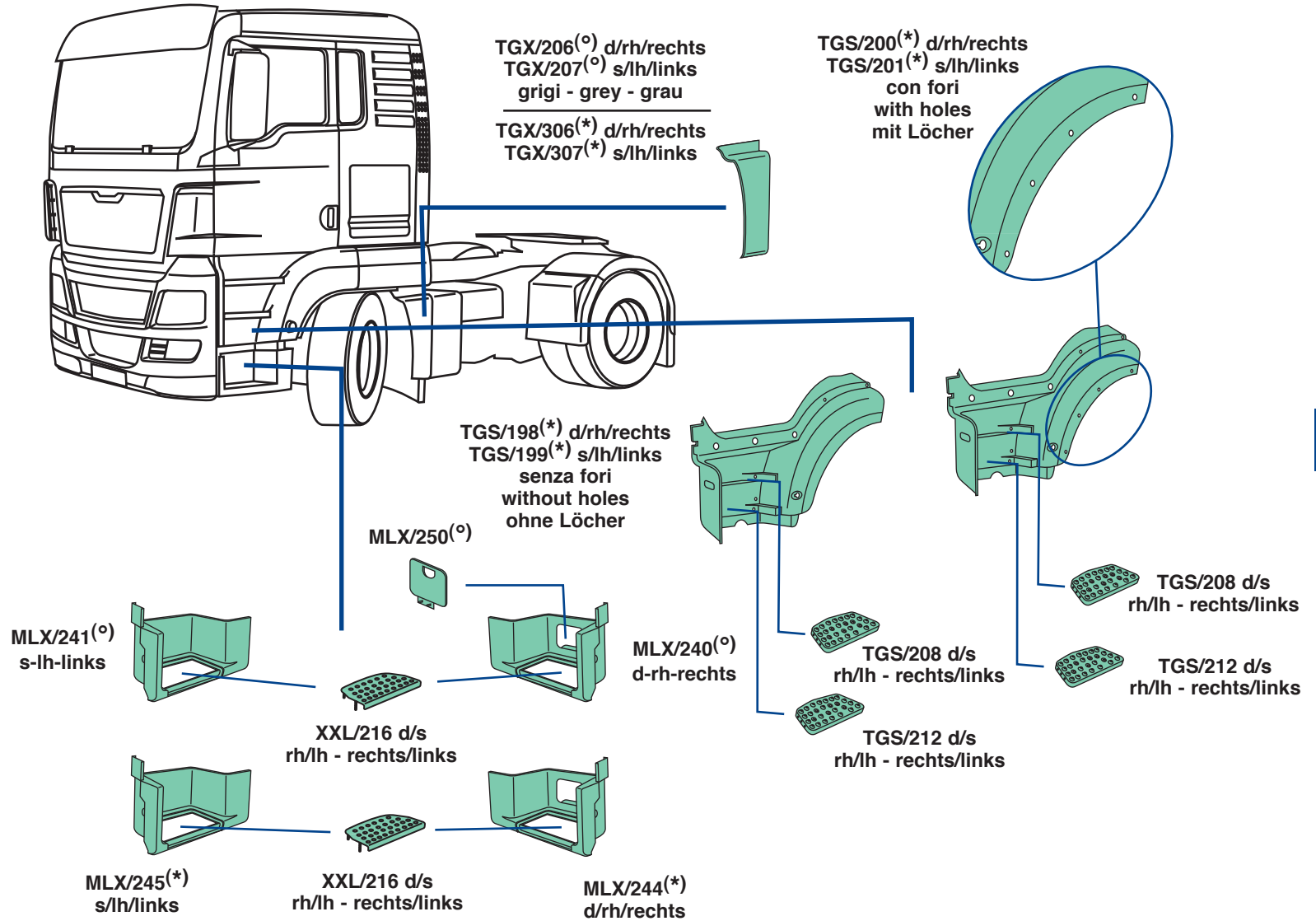

- (*) Vernice di fondo
- (*) Unprocessed
- (*) grundiert

- (°) Verniciato grigio
- (°) Grey painted
- (°) grau strukturlackiert

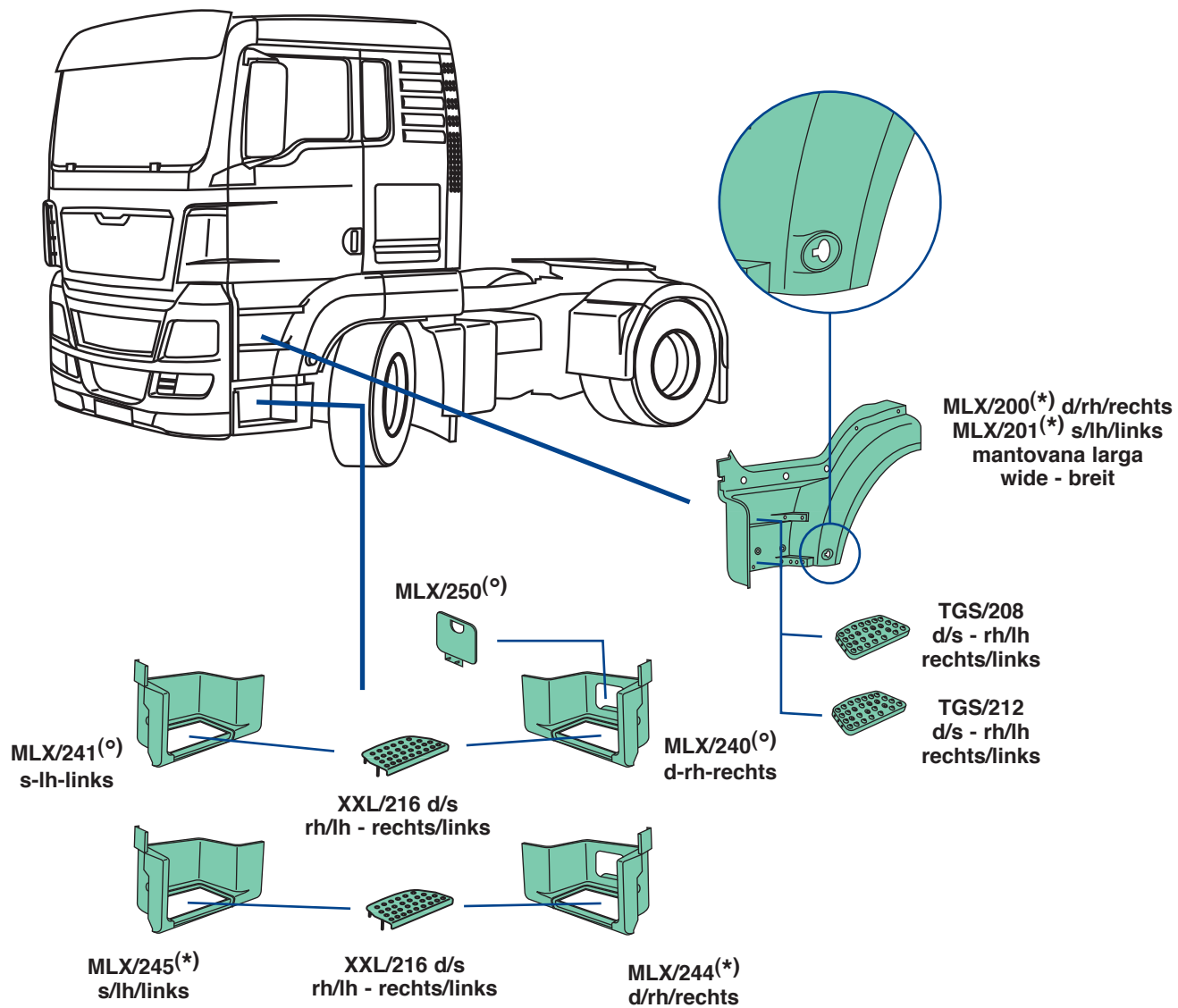

MAN TGS - MAN TGA XXL 2a serie-2nd series-2 Serie

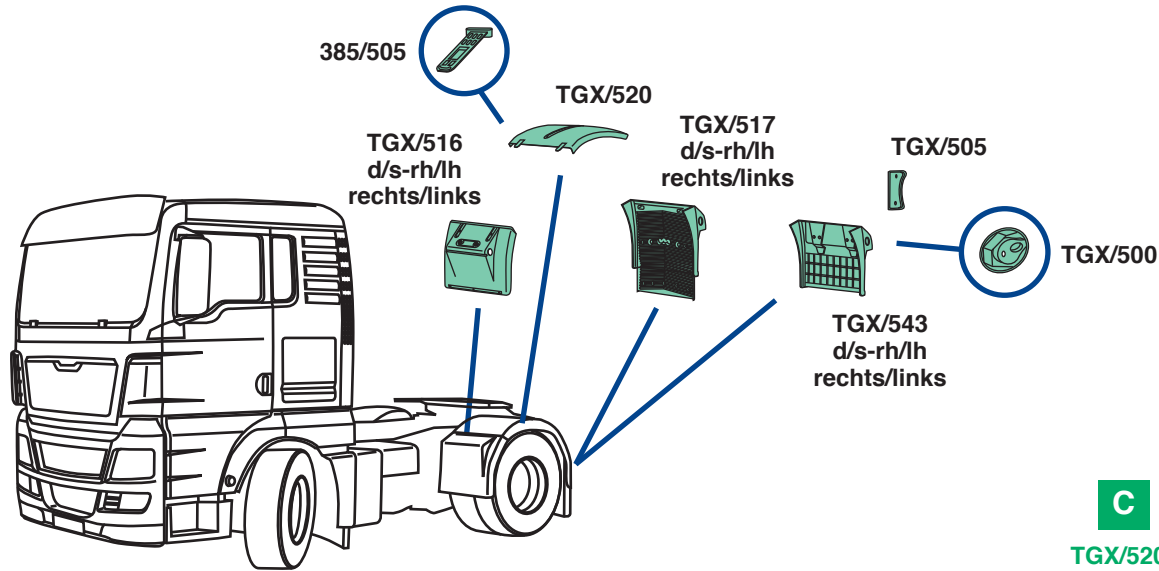

con antispray/with antispray/mit Spritzschutz **A**

senza antispray/without antispray/ohne Spritzschutz **B**

con cinghietti/with stretchers/mit Befestigungsgummi **C**

senza cinghietti/without stretchers/ohne Befestigungsgummi **D**

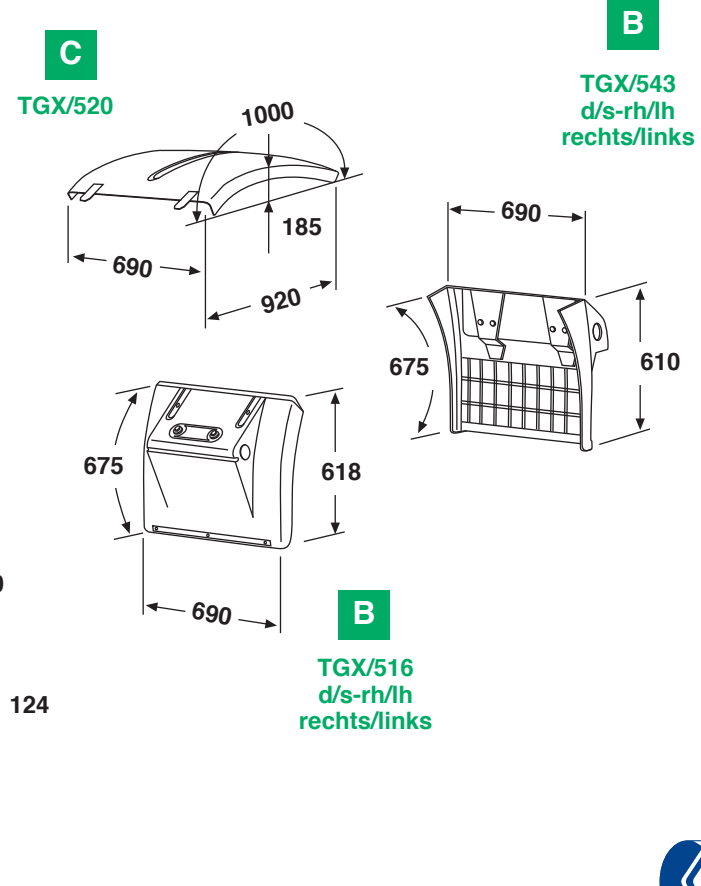

MAN TGS - MAN TGA XXL 2a serie-2nd series-2 Serie

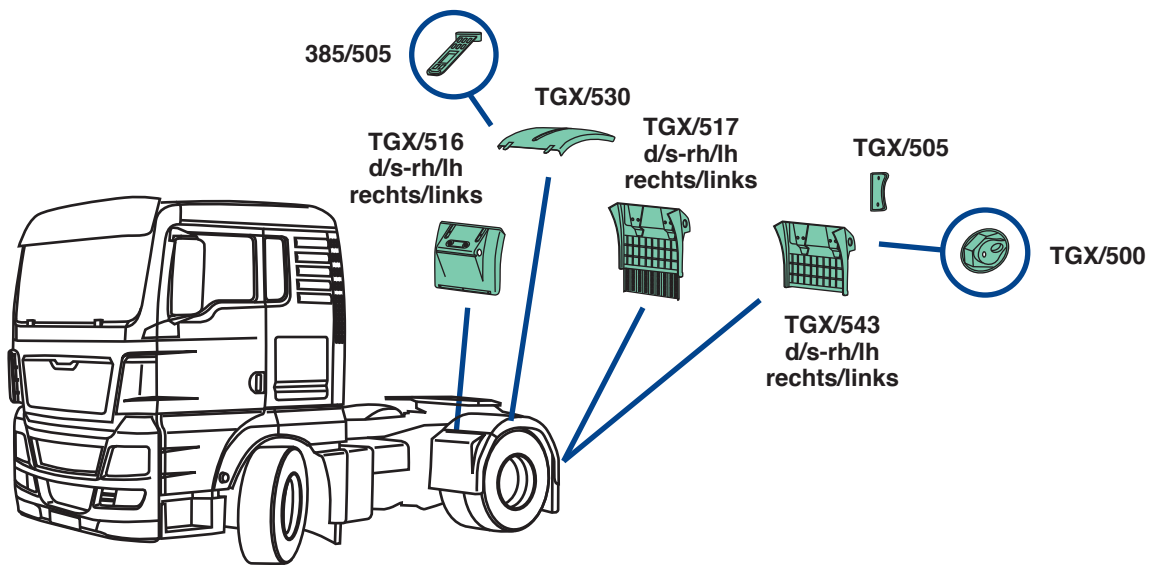

con antispray/with antispray/mit Spritzschutz **A**

senza antispray/without antispray/ohne Spritzschutz **B**

con cinghietti/with stretchers/mit Befestigungsgummi **C**

senza cinghietti/without stretchers/ohne Befestigungsgummi **D**

68

C
TGX/530

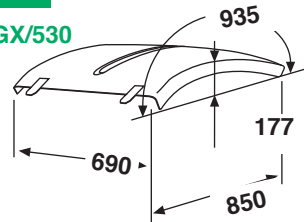

B
TGX/516
d/s-rh/lh
rechts/links

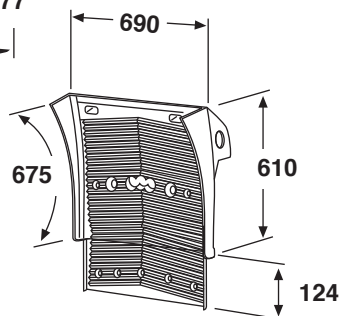
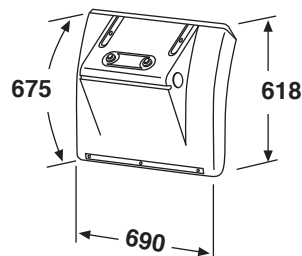

A
TGX/517
d/s-rh/lh
rechts/links

C

TGX/530

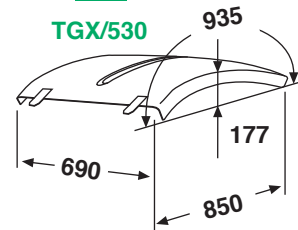

B

TGX/543
d/s-rh/lh
rechts/links

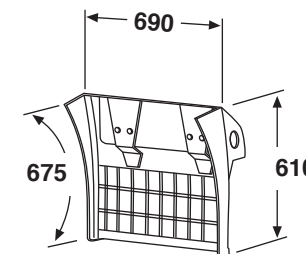

B

TGX/516
d/s-rh/lh
rechts/links

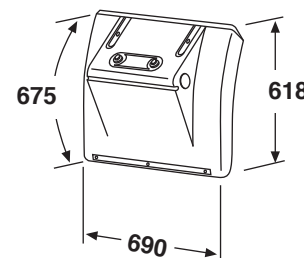

MAN TGS - MAN TGA XXL 2a serie-2nd series-2 Serie

Doppio Asse
Double Axle
Doppel-Achse

con antispray/with antispray/mit Spritzschutz **A**

senza antispray/without antispray/ohne Spritzschutz **B**

con cinghietti/with stretchers/mit Befestigungsgummi **C**

senza cinghietti/without stretchers/ohne Befestigungsgummi **D**

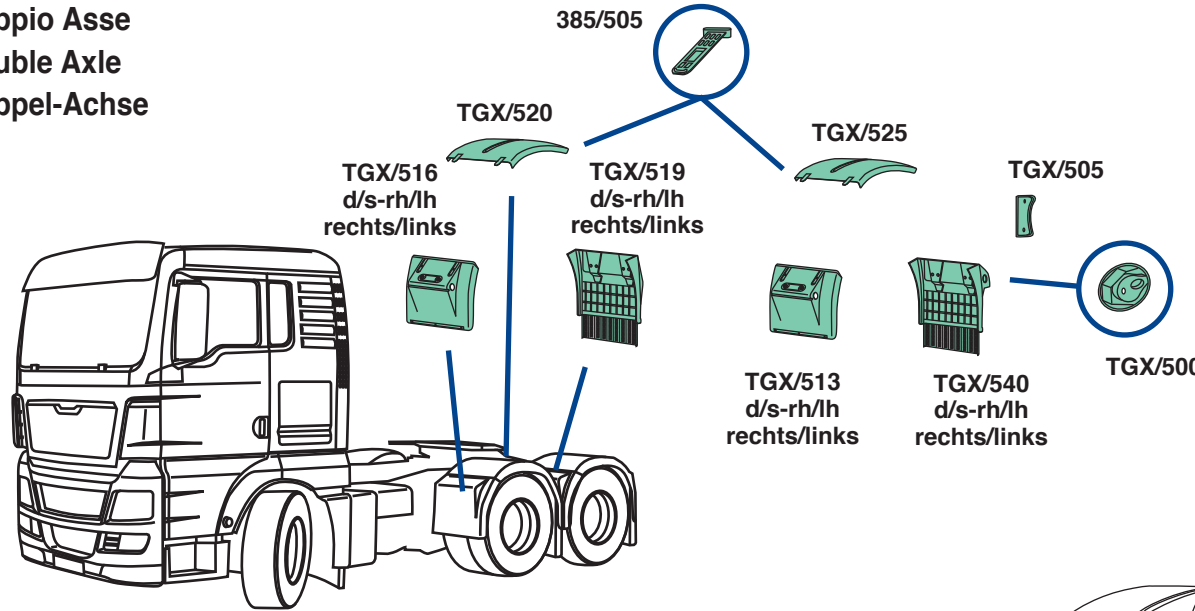

C
TGX/520

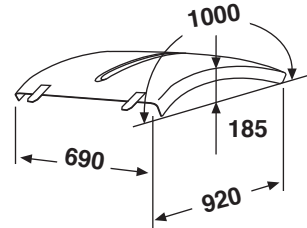

B
TGX/516
d/s-rh/lh
rechts/links

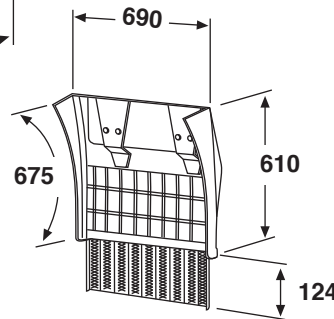
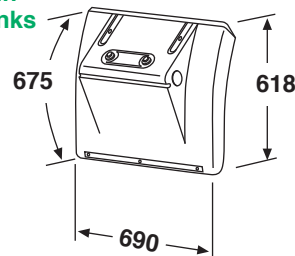

A
TGX/519
d/s-rh/lh
rechts/links

C
TGX/525

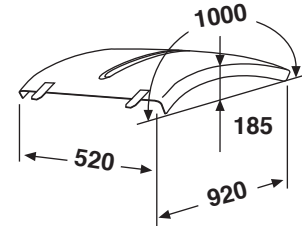

A
TGX/540
d/s-rh/lh
rechts/links

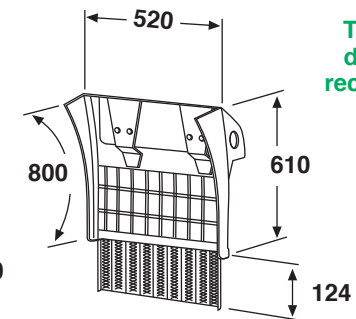

B
TGX/513
d/s-rh/lh
rechts/links

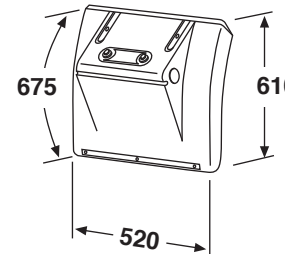

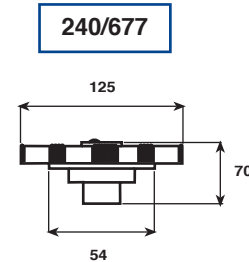
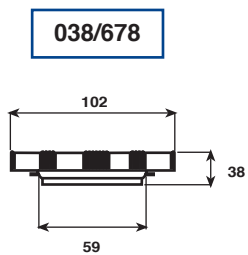
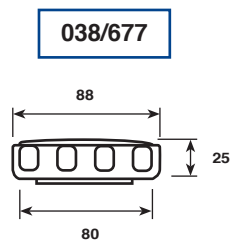
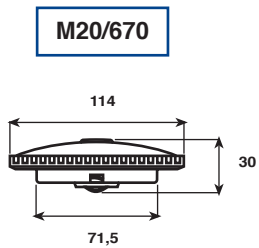

M20/670
con chiave
with key
mit Schlüssel



240/677
con chiave
with key
mit Schlüssel



038/677
sostituito da
replaced by
ersetzt durch
038/678

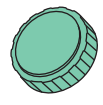

038/678
senza chiave
without key
ohne Schlüssel

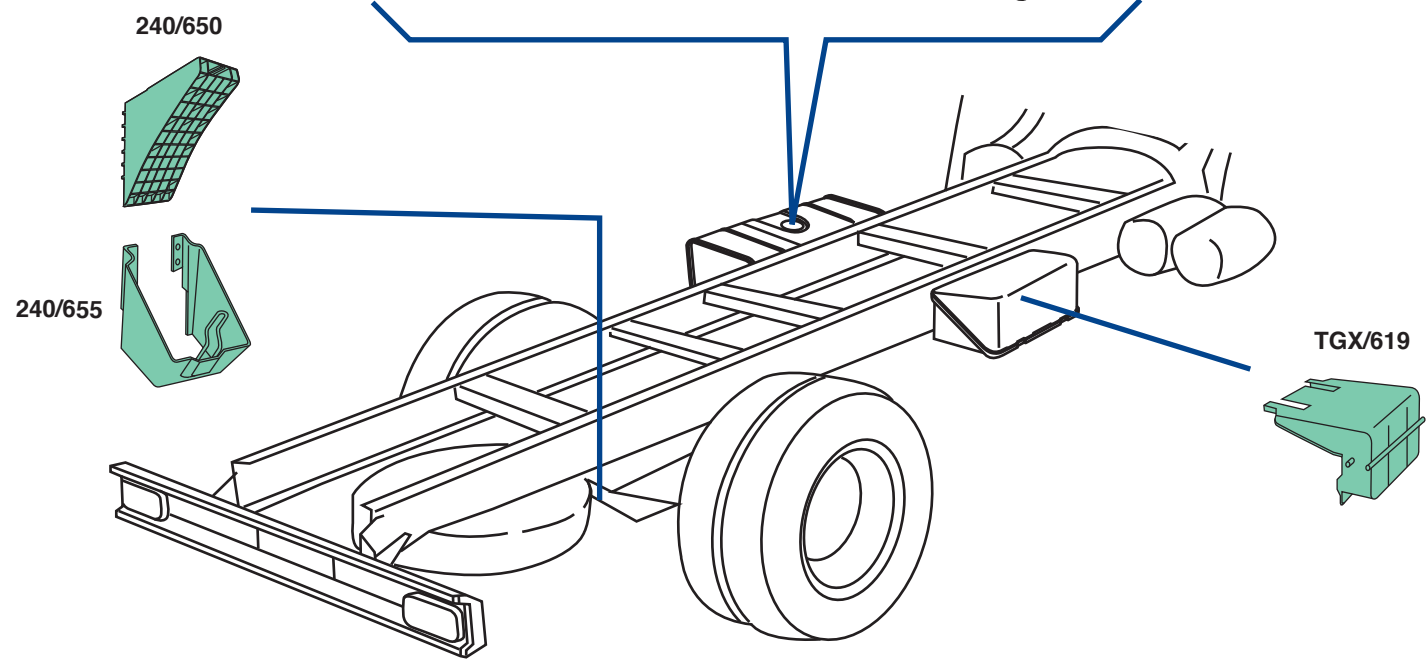
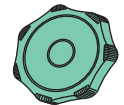



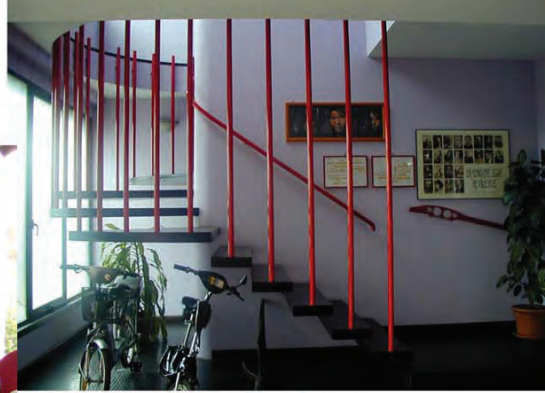

MAN

MAN TGS
CAVA/CANTIERE - YARD & QUARRY
Baustellenfahrzeug



73

(*) Vernice di fondo

(*) Unprocessed

(*) grundiert

74

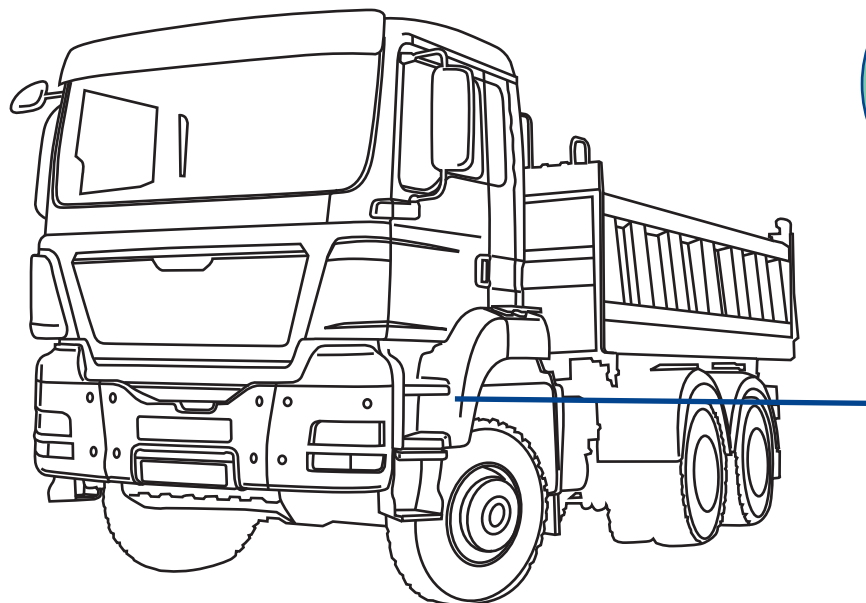

MLX/200(*) d/rh/rechts
MLX/201(*) s/lh/links
mantovana larga
wide - breit

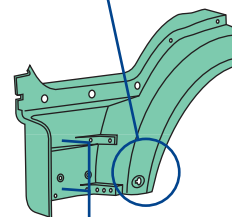
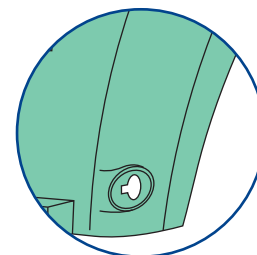

TGS/208
d/s - rh/lh
rechts/links



TGS/212
d/s - rh/lh
rechts/links

MLX/204(*) d/rh/rechts
MLX/205(*) s/lh/links
mantovana stretta
narrow - schmal

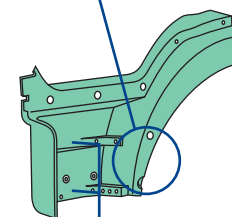
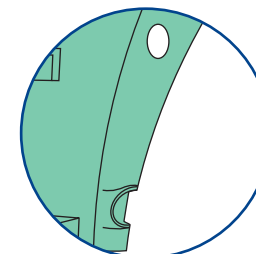

TGS/208
d/s - rh/lh
rechts/links



TGS/212
d/s - rh/lh
rechts/links

MAN

MAN TGX



75

- (*) Vernice di fondo
- (*) Unprocessed
- (*) grundiert

- (°) Verniciato grigio
- (°) Grey painted
- (°) grau strukturlackiert

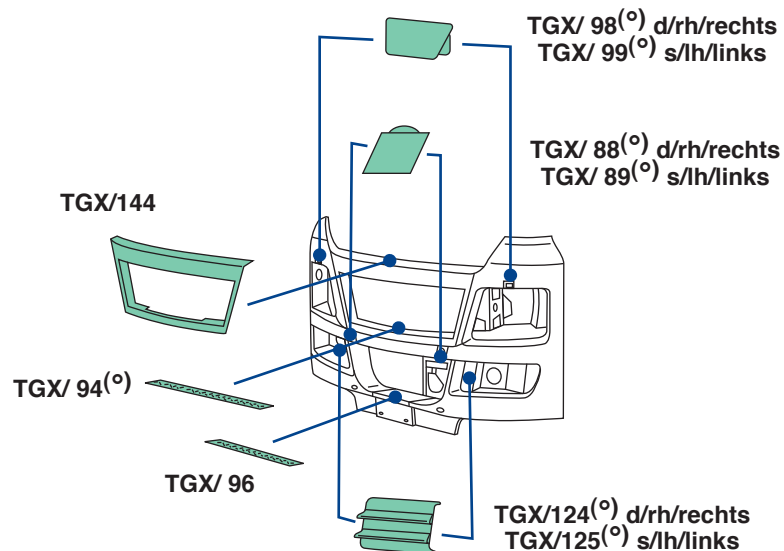

76

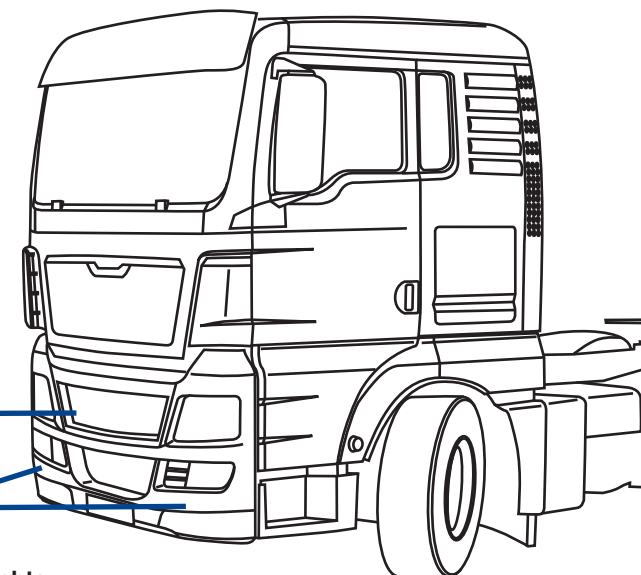
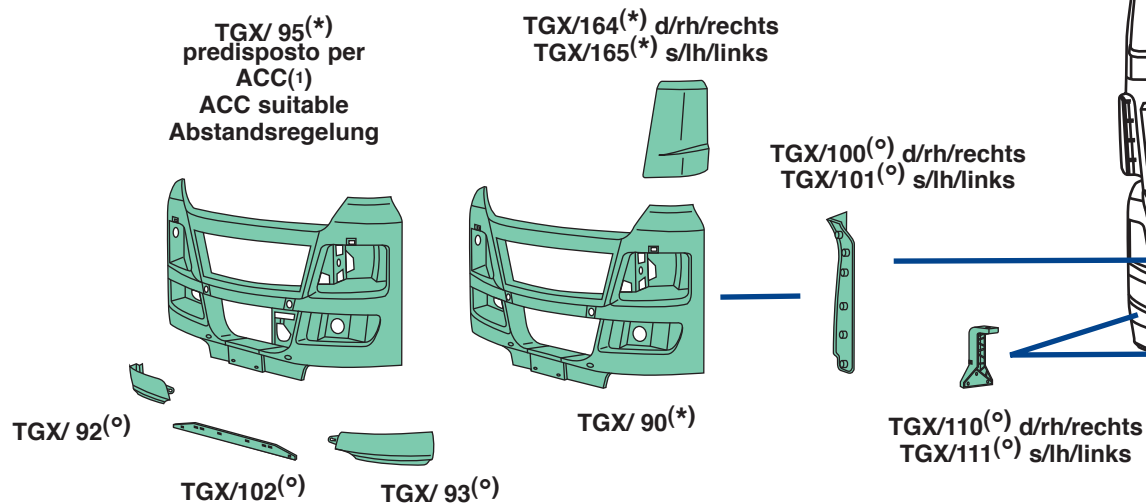

(1) Active Cruise Control - aktive Abstandsregelung

- (*) Vernice di fondo
- (*) Unprocessed
- (*) grundiert

- (°) Verniciato grigio
- (°) Grey painted
- (°) grau strukturlackiert

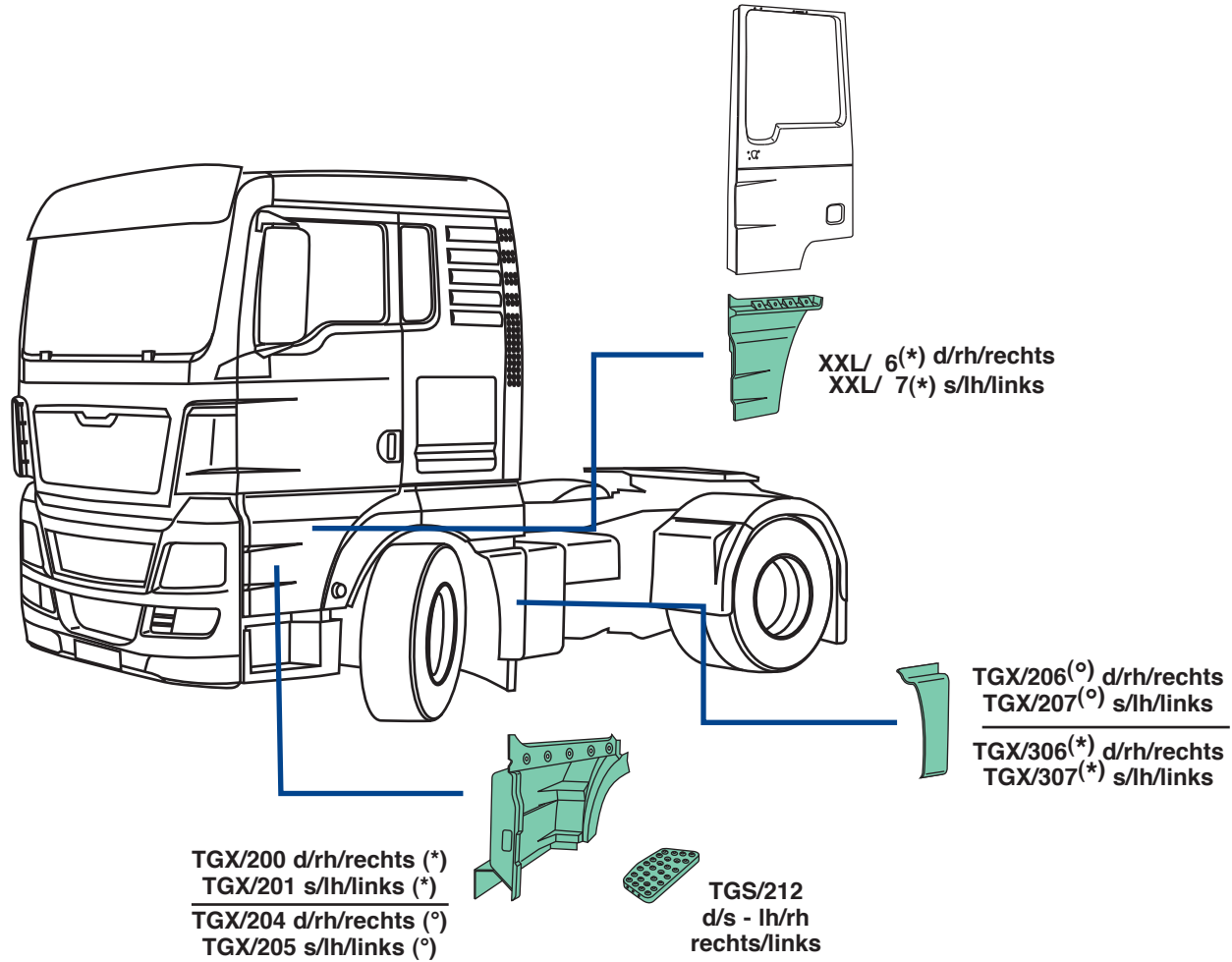

MAN TGS - MAN TGA XXL 2a serie-2nd series-2 Serie

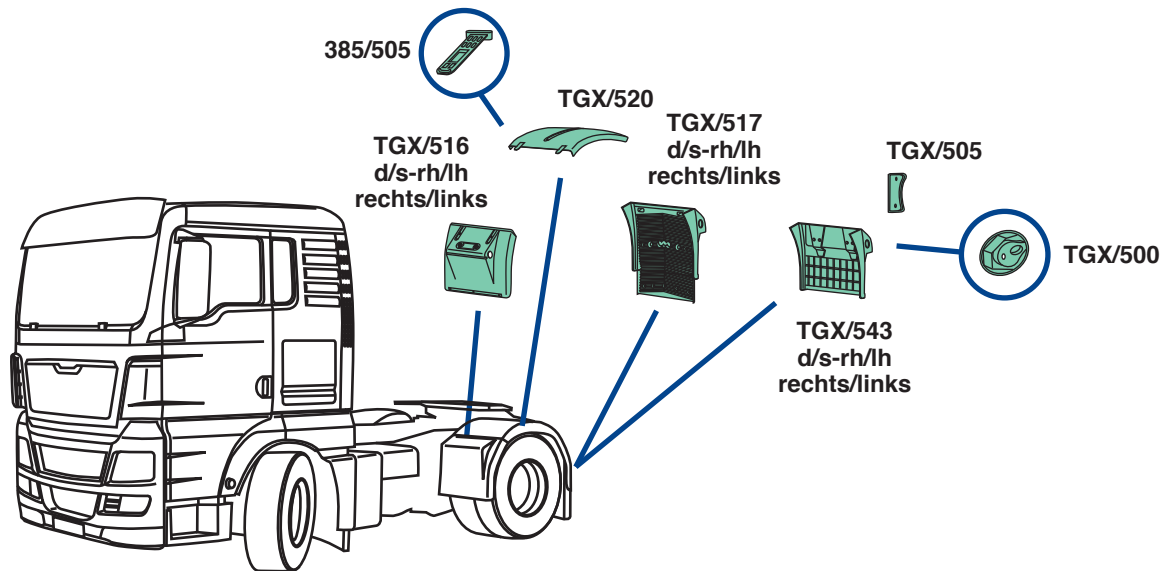

con antispray/with antispray/mit Spritzschutz **A**

senza antispray/without antispray/ohne Spritzschutz **B**

con cinghietti/with stretchers/mit Befestigungsgummi **C**

senza cinghietti/without stretchers/ohne Befestigungsgummi **D**

78

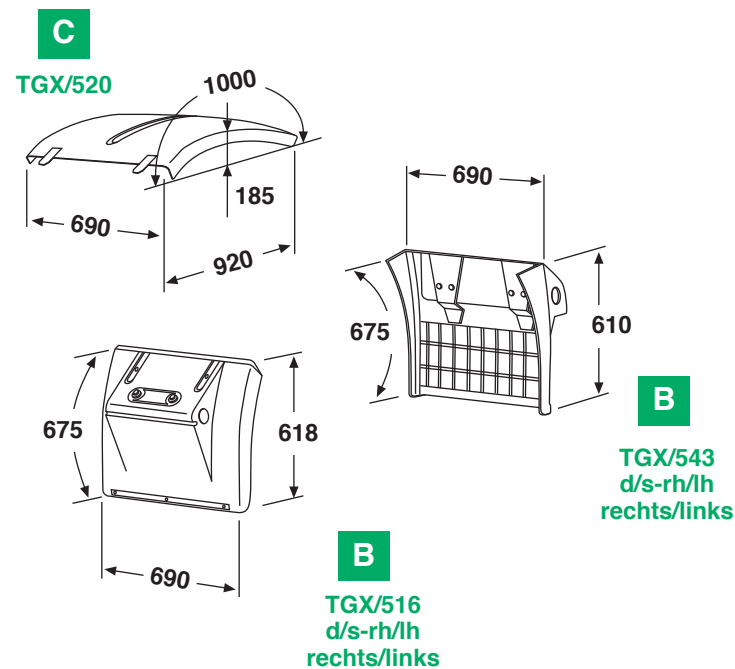
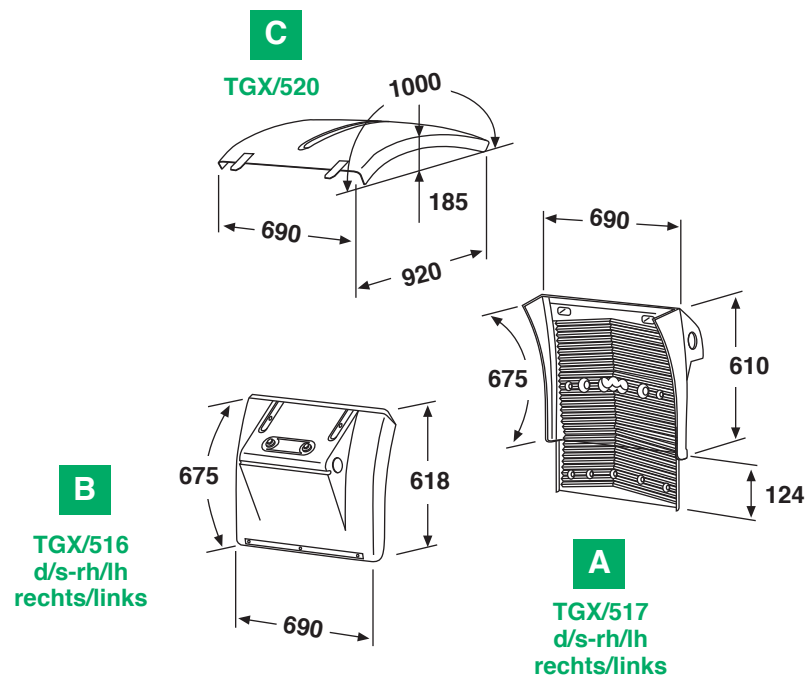

MAN TGS - MAN TGA XXL 2a serie-2nd series-2 Serie

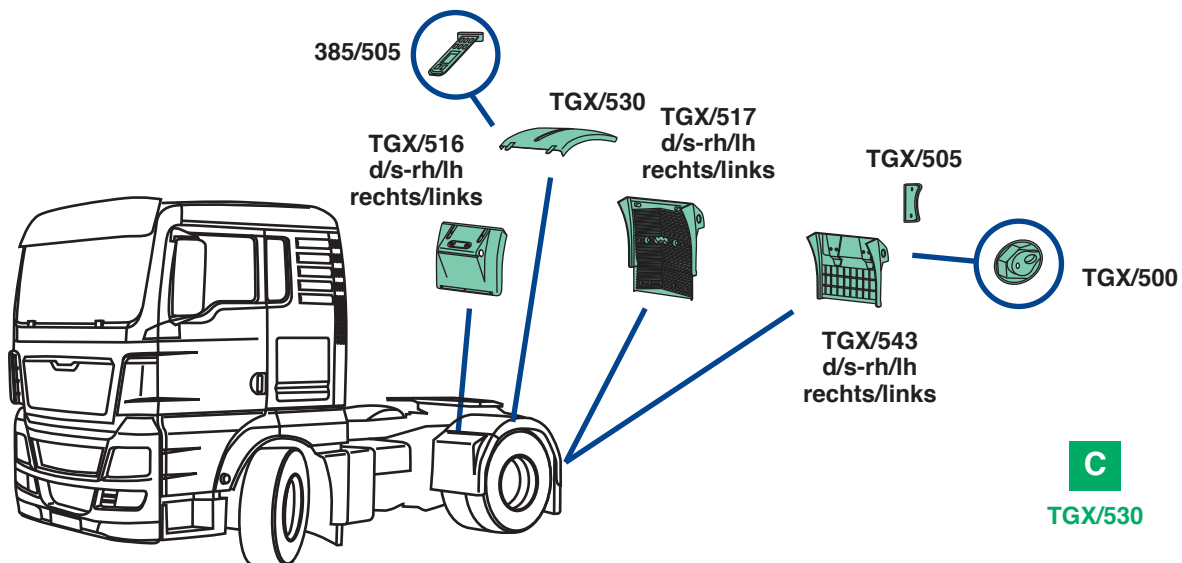

con antispray/with antispray/mit Spritzschutz **A**

senza antispray/without antispray/ohne Spritzschutz **B**

con cinghietti/with stretchers/mit Befestigungsgummi **C**

senza cinghietti/without stretchers/ohne Befestigungsgummi **D**

C
TGX/530

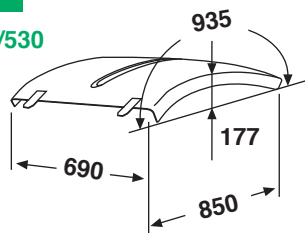

C
TGX/530

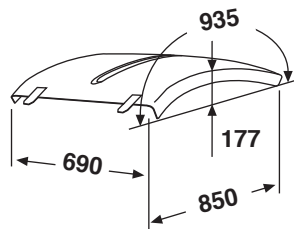

B
TGX/516
d/s-rh/lh
rechts/links

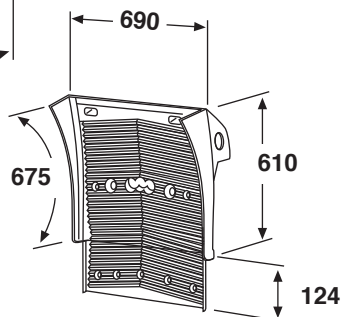
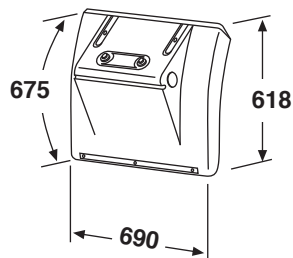

A
TGX/517
d/s-rh/lh
rechts/links

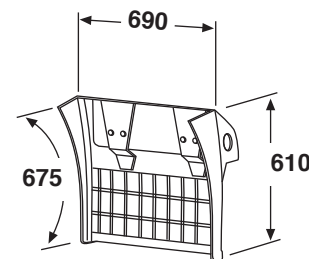

B
TGX/543
d/s-rh/lh
rechts/links

B
TGX/516
d/s-rh/lh
rechts/links

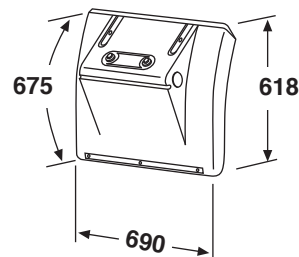

MAN TGS - MAN TGA XXL 2a serie-2nd series-2 Serie

Doppio Asse
Double Axle
Doppel-Achse

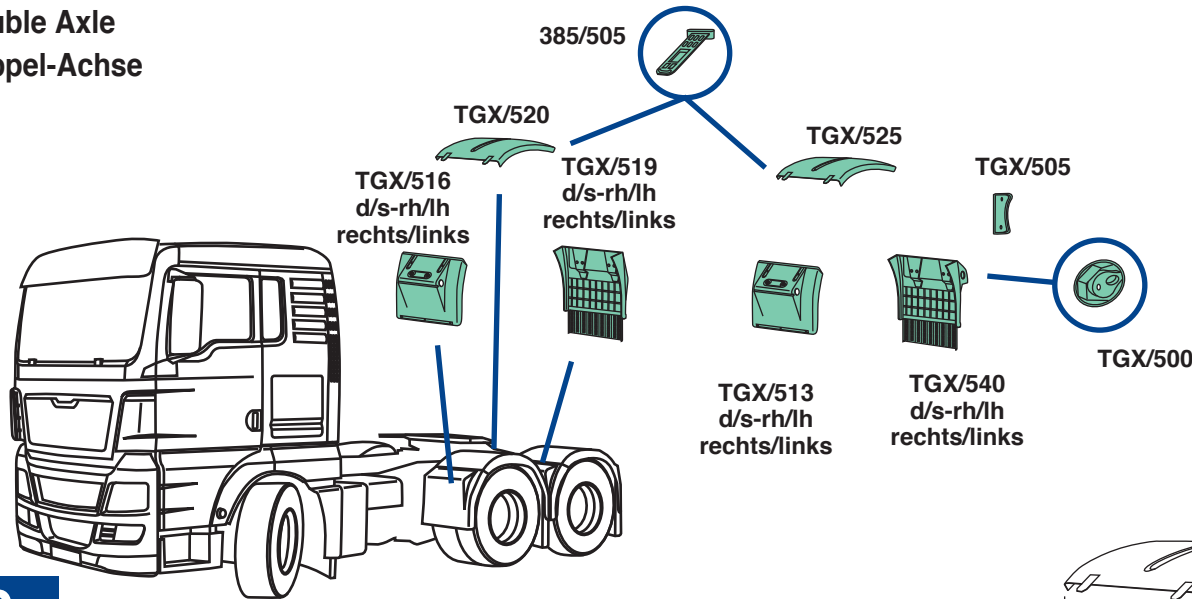

con antispray/with antispray/mit Spritzschutz **A**

senza antispray/without antispray/ohne Spritzschutz **B**

con cinghietti/with stretchers/mit Befestigungsgummi **C**

senza cinghietti/without stretchers/ohne Befestigungsgummi **D**

80

C
TGX/520

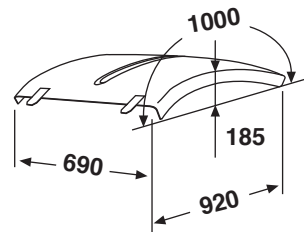

B
TGX/516
d/s-rh/lh
rechts/links

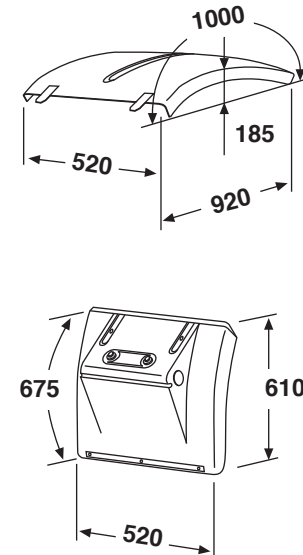
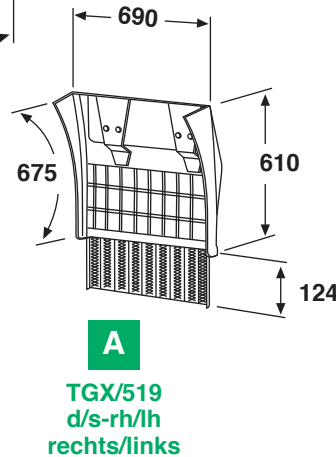
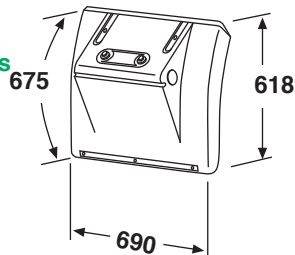

B
TGX/513
d/s-rh/lh
rechts/links

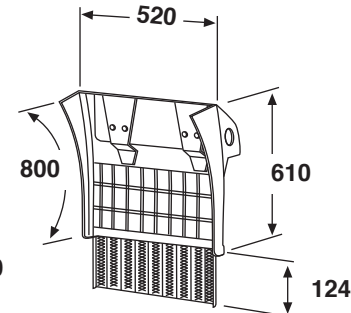
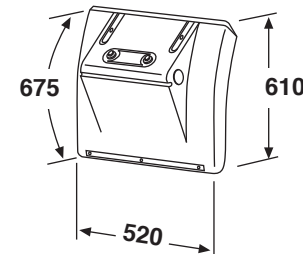

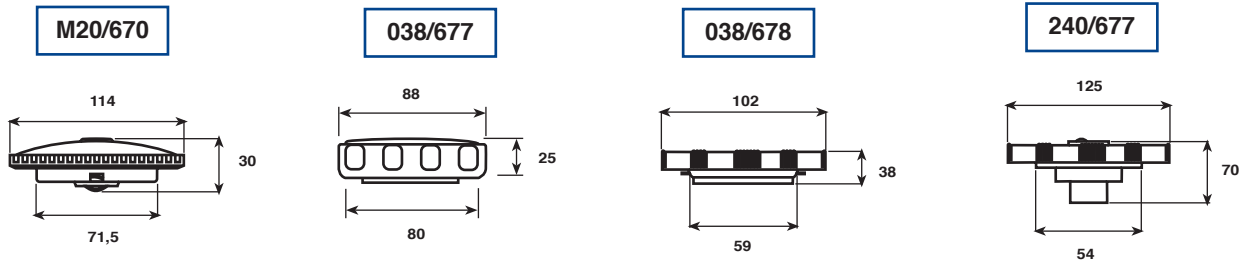

M20/670
con chiave
with key
mit Schlüssel



240/677
con chiave
with key
mit Schlüssel



038/677
sostituito da
replaced by
ersetzt durch
038/678



038/678
senza chiave
without key
ohne Schlüssel

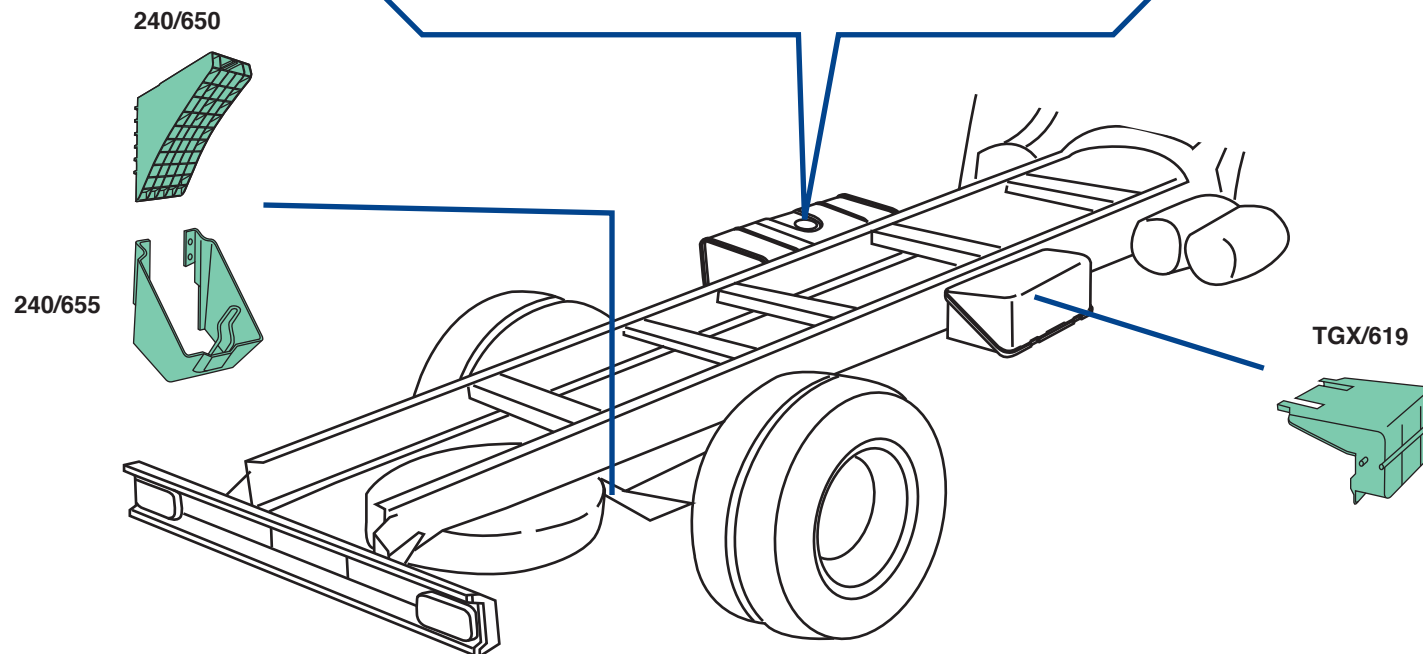





NEGLI STATI UNITI D'EUROPA CI TROVIAMO
NELL'HINTERLAND DI TORINO
(ZONA NORD/OVEST DELLA REGIONE ITALIA).

IN THE UNITED STATES OF EUROPE WE ARE LOCATED
ON THE OUTSKIRTS OF TURIN (IN THE NORTH/WEST
SECTION OF THE ITALIAN REGION).

DANS LES ETATS UNIS D'EUROPE
NOUS SOMMES LOCALISES EN BANLIEUE
DE TURIN (NORD/OUEST DE LA REGION ITALIE).

IN DER VEREINIGTEN STAATEN EUROPAS BEFINDEN
WIR UNS IM TURINER HINTERLAND
(NORDWEST ZONE DER REGION ITALIEN).



Covind spa
Strada della Cebrosa, 68 - 10036 Settimo t.se (TO) Italy
Tel. +39-011-8965711 - Fax +39-011-8977830
Sevizio Vendite Italia / Sales Dpt:
Tel. +39-011-8965719 - 8965714 - 8965702 - 8965723
Fax +39-011-8965756 E-mail: vendite@covind.it
Servizio Vendite Estero / Export Sales Dpt:
Tel. +39-011-8965716 - 8965736 - 8965721
8965739 - 8965735 - 8965738
Fax +39-011-8005149 E-mail: export@covind.it
Internet: www.covind.it

SGS



**BUREAU
VERITAS**